

RADIO CRAFT

AND POPULAR ELECTRONICS

TELEVISION-
CONTROLLED
MACHINE-GUN
SEE PAGE 144



DECEMBER

1944

25¢

CANADA 30¢

RADIO-ELECTRONICS IN ALL ITS PHASES



The "FIGHTINGEST" Radio in the Armed Services

THE men who do the fighting *like* the Motorola-built Handie-Talkie. They say without qualification . . . "It's fine . . . just like having a house telephone at your fingertips. We're never alone. We feel safer, stronger, because we're always in touch with our command post! Yes, sir, the Handie-Talkie is the 'fightingest' 2-way radio in this war!"

Now and as long as there is an enemy gun pointed at an American fighter, the business of Motorola Electronics Engineers will be *Communications for Victory*. They look forward eagerly to the time when their added knowledge and skills may be once more applied to the business of designing and producing Motorola Radios and Television for your greater listening pleasure.

The men and women who make Motorola military radio have won their fourth Army-Navy "E" award for "production beyond expectations". That, in their opinion, is the best way for us on the home front to express our gratitude for the courage and self-sacrifice of our men and women on the fighting fronts.



GALVIN MFG. CORPORATION • CHICAGO 51

"HANDIE-TALKIE"
another
Motorola Radio
FIRST!

*Have You Bought
That Extra War Bond?*

Motorola
Radio



**-Building this
A. M. SIGNAL GENERATOR**
gives you valuable experience. Provides amplitude-modulated signals for test and experiment purposes.

Radio Servicing pays many good money for full time work. Many others make \$5, \$10 a week EXTRA fixing Radios in spare time.

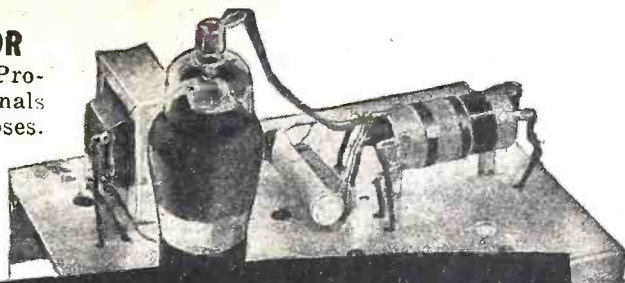

Learn RADIO by PRACTICING in Spare Time

with 6 Big Kits of Radio Parts I Send You

Here's a *practical* way to learn Radio at home in spare time—to train for a good Radio job, or start your own spare time or full time Radio Service Business! You get Radio EXPERIENCE building real Radio Circuits with kits of standard parts I send. You get solid KNOWLEDGE of Radio, Television, Electronic fundamentals from my easy-to-grasp lessons. You follow the same "50-50" method that has helped hundreds of beginners make \$5, \$10 EXTRA a week in spare time while learning—and prepare for good full time jobs at good pay.

Future Looks Bright for Trained Radio Technicians, Operators

The Radio Repair Business is booming. Profits are large and peacetime prospects are bright. Broadcasting Stations, Aviation Radio, Police Radio, Loudspeaker Systems, Radio Manufacturing, all employ trained Radio men at good pay.

Be Ready to Cash in on Jobs Coming With Television, Electronics

Think of the NEW jobs that Television, Frequency Modulation, Electronics, other Radio developments promise for the peacetime future. You have a real opportunity. I will train you to be ready to cash in when amazing wartime Radio developments are released for unlimited peacetime use.

Mail Coupon for Free Copy of Lesson and 64-page Illustrated Book

I will send you FREE a sample Lesson "Getting Acquainted with Receiver Servicing," to show you how practical it is to train for Radio in spare time. And with it I'll send FREE, my 64-page, illustrated book, "Win Rich Rewards in Radio." It describes many fascinating jobs in Radio, tells how you can get started. No obligation—no salesman will call. Just mail coupon in an envelope or paste it on a penny postal.—J. E. SMITH, President, Dept. 4NX, National Radio Institute, Washington 9, D. C.

My Course Includes Training in
TELEVISION • ELECTRONICS
FREQUENCY MODULATION



You build this
MEASURING INSTRUMENT
yourself early in the course—use it for practical Radio work on neighborhood Radios to pick up EXTRA spare time money!

You build this
SUPERHETERODYNE CIRCUIT
That brings in local and distant stations. You get *practical* experience putting this set through fascinating tests!

BE A SUCCESS in RADIO
I Will Train You at Home

Sample Lesson FREE

Gives hints on Receiver Servicing, Locating Defects, Repair of Loudspeakers, I.F. Transformer, Gang Tuner Condenser, etc., 31 illustrations. Study it—keep it—use it—without obligation! Mail coupon NOW for your copy!



GETTING ACQUAINTED WITH
RECEIVER SERVICING

GET BOTH 64 PAGE BOOK SAMPLE LESSON FREE

MR. J. E. SMITH, President, Dept. 4NX
NATIONAL RADIO INSTITUTE, Washington 9, D. C.

Mail me FREE, without obligation, Sample Lesson and 64-page book, "Win Rich Rewards in Radio." (No Salesman will call. Please write plainly.)

Age

Name

Address

City Zone State 4FR



RADIO CRAFT

AND POPULAR ELECTRONICS

Incorporating
SHORT WAVE CRAFT RADIO & TELEVISION

MEMBER
AUDIT BUREAU OF CIRCULATIONS

HUGO GERNSBACK, *Editor-in-Chief*
FRED SHUNAMAN, *Associate Editor*
I. QUEEN, *Editorial Associate*
ELMER FULLER, *Shortwave Editor*
A. PASCALE, *Production Manager*
G. ALIQUO, *Circulation Manager*
JOHN J. LAMSON, *Advertising Director*
ALFRED STERN, *Promotion Manager*

IN THE NEXT ISSUE

Radios of Forty Years Ago
Electronic Wire Recorder
Station Riding Troubles
New Radio Graphic Symbols
Electronic Gun Locator

Published by Radcraft Publications, Inc.

Publication Office: 29 Worthington Street,
Springfield 3, Mass.

Editorial and Advertising Offices: 25 West
Broadway, Tel. RE2-9690, New York 7, N. Y.

Chicago Advertising Office: Radio-Craft, 520
North Michigan Avenue, Tel. Superior 7306,
Chicago 11, Ill.

Cleveland Advertising Office: 405 Erie Bldg.,
Cleveland, Ohio. Burdette Phillips, Manager.
Tel. Main 9645.

Los Angeles Office: Robt. H. Deibler & Asso-
ciates, 403 W. Eighth St., Tucker 1579.

RADIO-CRAFT is published monthly on the
25th of the month preceding that of date;
subscription price is \$2.50 per year in U. S.
(In foreign countries, 75c additional per year
to cover postage; Canada, 50c additional.)
Special rates for members of the Armed Forces
in U. S., or those addressed by A.P.O. or F.P.O.
mail, \$2.00. Entered at the post office at
Springfield as second-class matter under the
Act of March 3, 1879. All communications
about subscriptions should be addressed to:
Circulation Manager, Radio-Craft, 29 Worthing-
ton St., Springfield 3, Mass.

Notice of CHANGE of ADDRESS should
reach us at least one month in advance. When
ordering a change, please furnish an address
stencil impression from a recent wrapper if
you can. Address changes cannot be made
without the old address as well as the new.

Foreign Agents

London—Atlas Publishing and Distributing
Co., Ltd., 18 Bride Lane, Fleet St., London,
E.C. 4.

Melbourne—McGill's Agency, 179 Elizabeth
St., Australia.

Text and illustrations of this magazine are
copyright and must not be reproduced without
permission of the copyright owners.
Copyright, 1944, Radcraft Publications, Inc.

Contents December, 1944 Volume XVI, No. 3

Editorial: U. S. Robot Bombs	by Hugo Gernsback	139
Radio-Electronics Monthly Review		140

TELEVISION

1944—Television's Year		142
Television Controlled Machine Gun	by Hugo Gernsback	144
"Telechrome"		149
Iconoscope		181

ELECTRONICS

Problems of Mobile Radio	by J. H. Wallis	145
Industrial Electronics, Part X	by Raymond F. Yates	153
Alien Enemy Patents	by I. Queen	158

WARTIME RADIO

Marines and Radio	by Corp. Ernie Harwell and 1st Lieut. Cyril D. Jeffcoat	143
Emergency Radio	by Loyal S. Fox and Mark Brice	146
"Kitchen Sink" Trainer	by S. R. Winters	148

RADIO TRAINING

Broadcast Equipment, Part IV	by Don C. Hoefler	147
Matching Loudspeakers	by Fred Shunaman	150
The Square Wave Generator	by Harry Bergquist	151

SOUND

Speech Amplifier Design, Part III	by Robert F. Scott	154
-----------------------------------	--------------------	-----

SERVICING

Automatic Record Changers, Part II	by John Needre	152
Battery Conversions	by W. A. Rieveley	155

CONSTRUCTION

11-Tube Superheterodyne	by Emmett Brightwell	156
The "Homebroadcaster"	by Arthur W. Crampton, Jr.	157

DEPARTMENTS

New Radio-Electronic Devices		160
Radio-Electronic Circuits		162
Try This One!		164
The Question Box		166
World-Wide Station List	Edited by Elmer R. Fuller	171
Technotes		186
The Mail Bag		188
Book Reviews		191

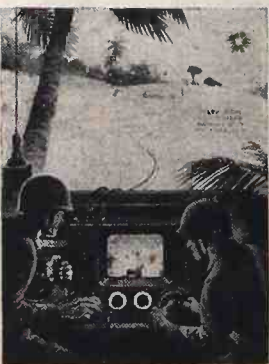

ON THE COVER

This month's cover shows the future television-controlled robot machine gun. A gun crew directs killing fire against the advancing enemy while the gun operators remain safely out of range of their baffled victims, who are cut down by a machine which can be put out of action only by physical destruction, at a high cost in enemy man-power.

AGAIN!



For the 5th time
hallicrafters
employees win
Army-Navy
"E" Award!

First exclusive manufacturer of short wave radio equipment to receive the coveted Army-Navy "E" Award for the fifth time... the result of the continued and untiring devotion to duty of the company's 1,500 employees.

hallicrafters

THE HALLICRAFTERS COMPANY • MANUFACTURERS OF RADIO AND ELECTRONIC EQUIPMENT • CHICAGO 16, U. S. A.



Builders of the famous SCR-299

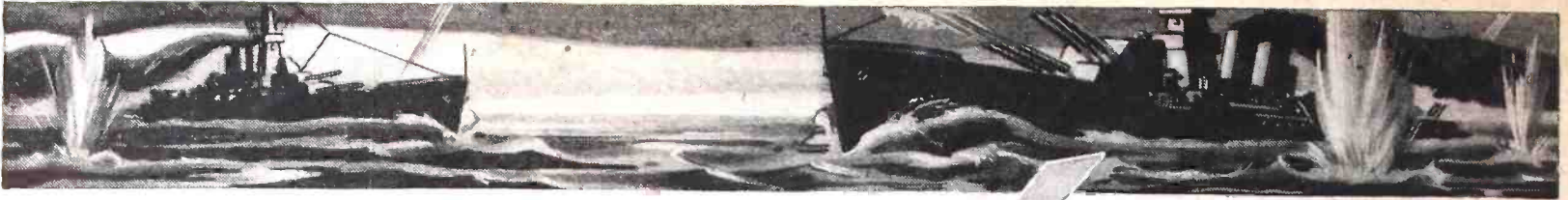

“They filled a gap –”

• The following is quoted from a letter received from a Chief Radio Mechanic in the U. S. Navy and is one of a series of real life stories of Hallicrafters radio equipment in action . . .

“During the early days of the South Pacific offensive the cruiser on which I was serving was called upon unexpectedly to maintain a watch on five extra frequencies. All of our regular receivers were already in use and it was impossible to use any of them for this emergency.

“Some thoughtful predecessor in peace time had purchased eight Hallicrafters S-20-R receivers with ship’s service funds for use as broadcast receivers in the crew’s quarters. We dug them out of the lockers and tested them. All were in

excellent condition after months of vibration, humidity and tropical heat. We stacked them on an operating table in the radio room and set them on the specified frequencies.

“The first call on all frequencies was heard S-5 and voice signals came through clear as a bell. These receivers required no attention other than volume adjustment and the volume was sufficient to over-ride the noise of guns on our own ship. Their reliability in a tough spot amazed us. They filled in a big gap in the chain of command and filled it well.”

The S-20-R mentioned above is known to thousands as Hallicrafters famous “Sky Champion.” It has a frequency range of 550 kc. to 43 mc., continuous in 4 bands and 9 tubes.

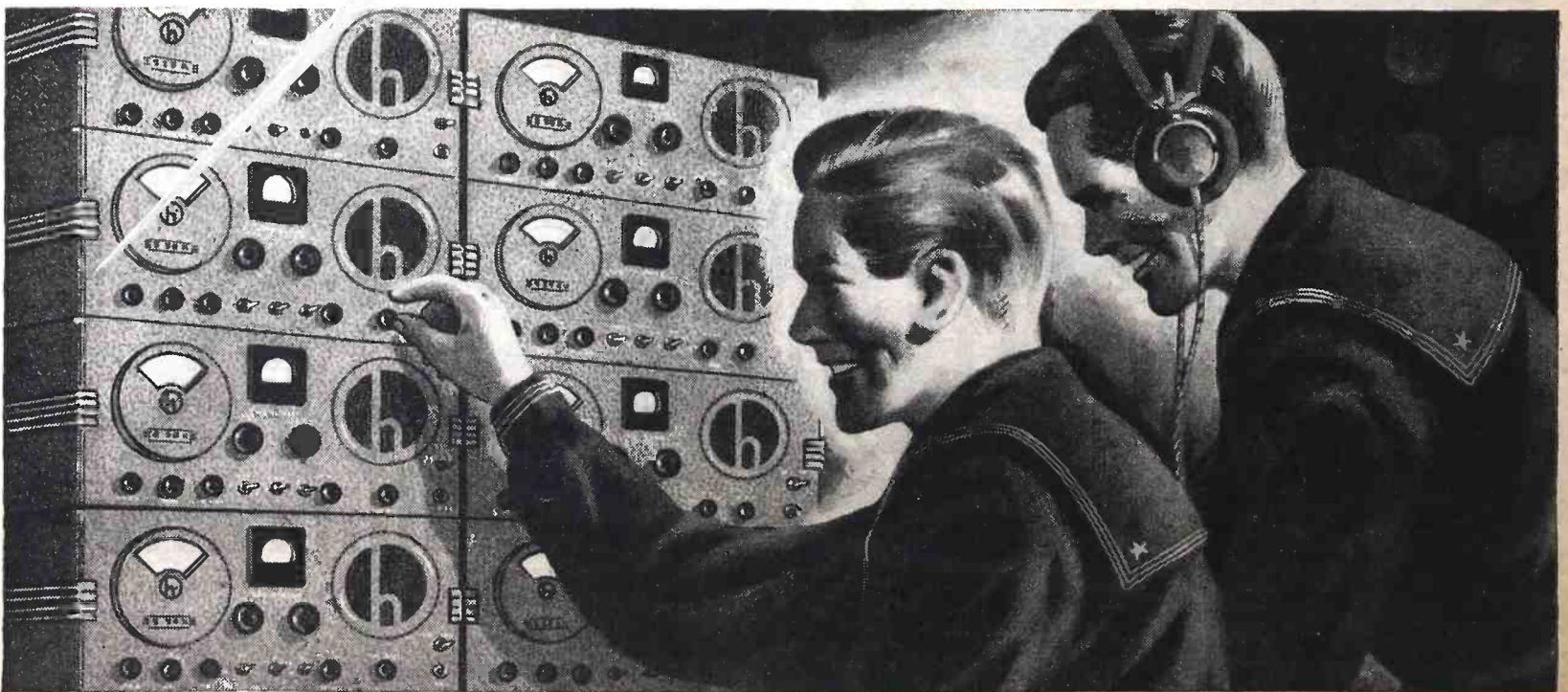

BUY A WAR BOND
TODAY!

hallicrafters RADIO

THE HALLICRAFTERS COMPANY, MANUFACTURERS OF RADIO AND ELECTRONIC EQUIPMENT, CHICAGO 16, U.S.A.

SPRAYBERRY RADIO TRAINING

Gives you Both

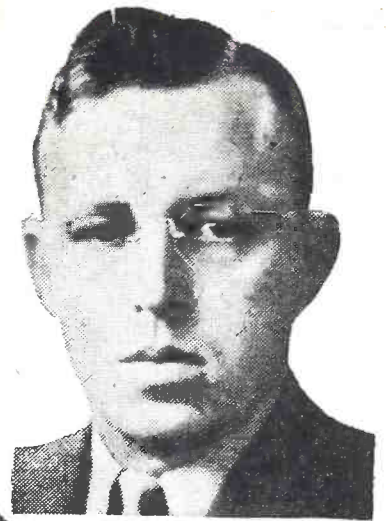

FULL RADIO SET SUPPLIED FOR SHOP PRACTICE!

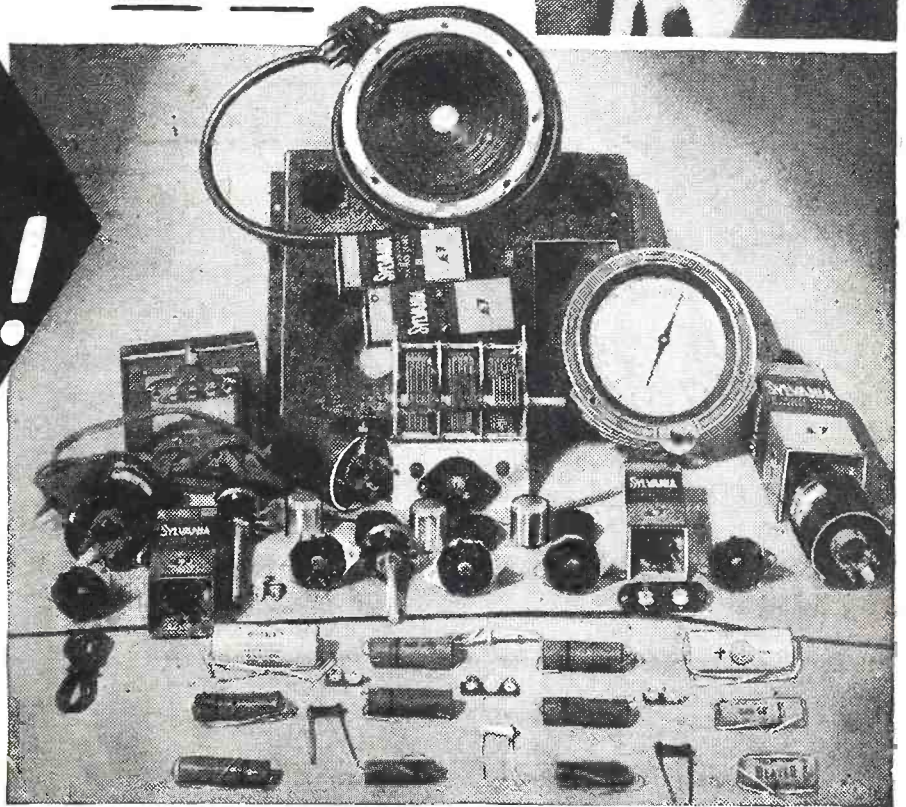

HERE'S THE ONE PRACTICAL WAY TO TRAIN FOR BIG EARNINGS AHEAD IN RADIO-ELECTRONICS & TELEVISION

The offer I make you here is the opportunity of a lifetime. It's your big chance to get ready for a wonderful future in the swiftly expanding field of Radio-Electronics INCLUDING Radio, Television, Frequency Modulation and Industrial Electronics. Be wise! NOW'S the time to start. No previous experience is necessary. The Sprayberry Course starts right at the beginning of Radio. You can't get lost. It gets the various subjects across in such a clear, simple way that you understand and remember.

I'll Show You a New, Fast Way to Test Radio Sets Without Manufactured Equipment

The very same Radio Parts I supply with your course for gaining pre-experience in Radio Repair work may be adapted through an exclusive Sprayberry wiring procedure to serve for complete, fast, accurate Radio Receiver trouble-shooting. Thus under Sprayberry methods you do not have one cent of outlay for manufactured Test Equipment which is not only expensive but scarce.

Prepares You For a Business of Your Own or Good Radio Jobs . . . Civilian or Military

My training will give you the broad, fundamental principles so necessary as a background no matter which branch of Radio you wish to specialize in. I make it easy for you to learn Radio Set Repair and Installation Work. I teach you how to install and repair Electronic Equipment. If you enter the Army, Navy or Marines, my training will help you win higher rating and better pay.

JUST OUT! FREE! HOW TO READ RADIO DIAGRAMS AND SYMBOLS

... a valuable new book which explains in simple, non-technical English how to read and understand any Radio Set Diagram. Provides the quick key to analyzing any Radio circuit. Includes translations of all Radio symbols. Send for this FREE book now while supply lasts and along with it I will send you another big FREE book describing my Radio-Electronic training.

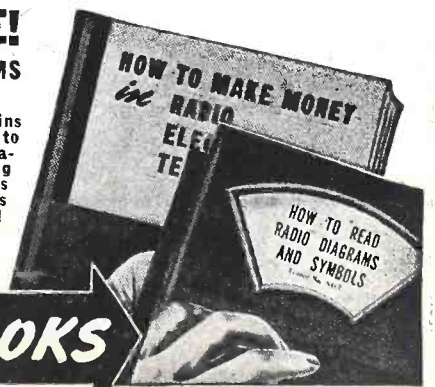

GET FREE BOOKS

SPRAYBERRY ACADEMY OF RADIO
F. L. Sprayberry, Pres.
Box 500TM
Pueblo, Colorado

Please rush my FREE copies of "HOW TO MAKE MONEY IN RADIO, ELECTRONICS and TELEVISION," and "HOW TO READ RADIO DIAGRAMS and SYMBOLS."

Name Age.....

Address

City State.....

Tear off this coupon, mail in envelope or paste on penny postcard.



MEN OF MEISSNER

... ON THEIR FACES ARE THE SMILES OF PRIDE IN WORK WELL DONE

In the little city of Mt. Carmel, Illinois — famous for music and electronics — the men of the Meissner Manufacturing Company are now devoting their skill and experience to speeding the final

day of Victory. All were hand-picked for their jobs — many “grew-up” in the business, doing their share toward making the name Meissner stand for the ultimate in radio quality. They have had the pleasure of turning out perfect work — felt the thrill and satisfaction that comes with achievement. And in the bright, post-war world of tomorrow, it will be these same men of Meissner that add new fame to the name of Meissner radio and other electronic equipment.



Skill PLUS “Know How” — The secret of Meissner’s reputation for superb quality precision work is more than just great skill and intricate machines. It is a combination of these two, PLUS the “know how” that comes only from years of experience.



Expert — His is a heritage for producing far-famed quality. Mt. Carmel, Illinois, is said to have more electronic technicians per thousand population than any other city in America.

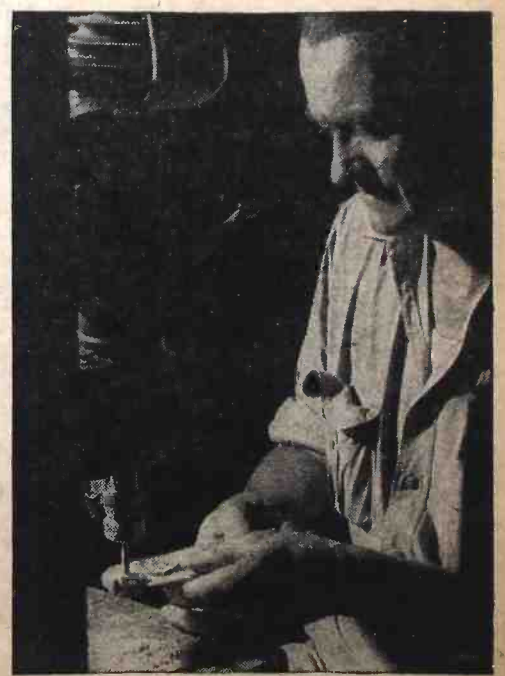

Meissner’s Precision-el — that’s the name earned by the Meissner personnel for their skill, and for the pride they have taken in doing their precision work right.



MEISSNER MANUFACTURING COMPANY • MT. CARMEL, ILL.

ADVANCED ELECTRONIC RESEARCH AND MANUFACTURE

Export Division: 25 Warren Street, New York; Cable, Simonrice, New York

RADIO-CRAFT for DECEMBER, 1944

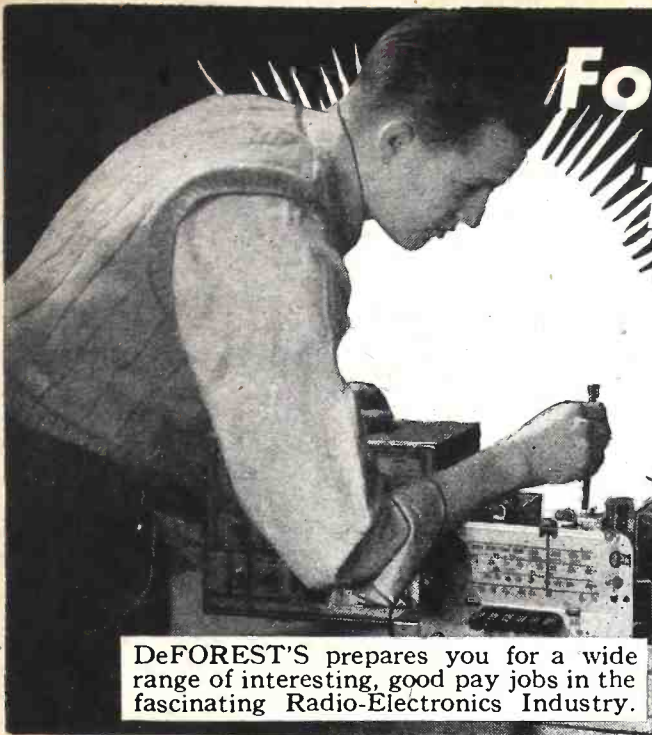

DeFOREST'S prepares you for a wide range of interesting, good pay jobs in the fascinating Radio-Electronics Industry.

**For Good Jobs TODAY...
TOMORROW...LEARN**

RADIO ELECTRONICS

DeFOREST'S A-B-C WAY

THE fast-moving Opportunity Field of Radio-Electronics needs many trained men! Let us show you how to get ready to take advantage of the breaks—the good jobs—the satisfying pay checks of today, and the bright postwar opportunities of tomorrow. Write for DeFOREST'S big, free book—"VICTORY FOR YOU!"

You see how you may cash-in on a field that includes F.M. Radio, Communication Radio, Electronics, Broadcast Radio, Motion Picture Sound, Radio Sales and Service, or a Radio business of your own.

You see how DeFOREST'S has helped many get their start in Radio-Electronics—helped them to good pay jobs in one of today's most promising industries—helped others to preferred military classifications with higher ratings and better pay. Helped others to full and part time sales and service businesses of their own. Mail the coupon NOW—TODAY! See how DeFOREST'S can help YOU get started toward this fascinating work by means of its effective "A-B-C" Training Method—in your spare time, at home.

A GET INTERESTING, LOOSE-LEAF LESSONS
DeFOREST'S TRAINING includes 90 modern, well-illustrated loose-leaf lessons, prepared under the supervision of one of the world's foremost Radio authorities, Dr. Lee DeForest—inventor of the Audion tube which helped make modern Radio possible.

B WORK AT HOME WITH PRACTICAL EQUIPMENT
You "learn-by-doing" with eight big kits of standard Radio parts and assemblies—working out 133 interesting experiments to gain valuable experience at home. You experiment with Light Beam Transmission. You build and operate an Aviation Band Radio Receiver, Wireless Microphone, 5-tube Superheterodyne Receiver, an intriguing "Electric-Eye" device—and many other projects.

C "LEARN BY SEEING" MOVIES AT HOME
You use a genuine DeVERY 16mm. Motion Picture Projector and Films to help you learn Radio faster... easier. Hidden Radio-Electronic action comes to life! You see Electricity in motion—*Electrons on the March*... DeFOREST'S also provides an effective EMPLOYMENT SERVICE which has long-established contacts with employers with whom we have placed many trained radio men. Act now! Mail the coupon!

READ WHAT THESE DeFOREST MEN SAY!

"Let me say that since being on this job I have many times expressed the fact that I wouldn't take a lot of money for the training I had from your organization. It has helped me immensely."—*Richard Strouhal, Oklahoma.*

"I have obtained employment with the... Mfg. Company. You may be interested to know they speak very highly of DeForest's students and state they have had excellent results with your men whom they have employed."—*Clifford Taylor, Mass.*
"As a result of DeForest's Training, I am doing very well. If my income doesn't range between \$50.00 and \$75.00 per week, I figure something is wrong."—*Lyle Rielly, Wisconsin.*

VETERANS! The Billion Dollar Radio-Electronic Industry, with its Manufacturing, Servicing, Broadcasting, Communications, and many other promising fields, invites your careful consideration. See how DeFOREST'S helps you prepare for a good pay job, or a business of your own in one of America's most promising fields.

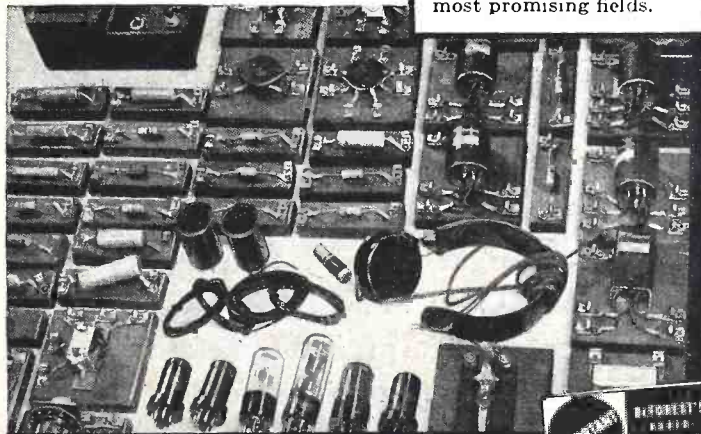

DeFOREST'S TRAINING INCLUDES INSTRUCTION IN MOTION PICTURE SOUND EQUIPMENT, FM RADIO AND TELEVISION

DeFOREST'S HOME MOVIES HELP YOU LEARN FASTER—EASIER

See Radio Circuits in Action—*Electrons on the March!*

DeFOREST'S TRAINING, INC.
CHICAGO 14, ILLINOIS

DeFOREST'S TRAINING, INC., Dept. RC-9
2535-41 N. Ashland Ave.
Chicago 14, Illinois, U.S.A.

Please send me your "VICTORY FOR YOU" book and KIT FOLDER, FREE and without obligation.

Name Age
Address
City State

If under 16, check here for special information.
 If a veteran of World War II, check here.

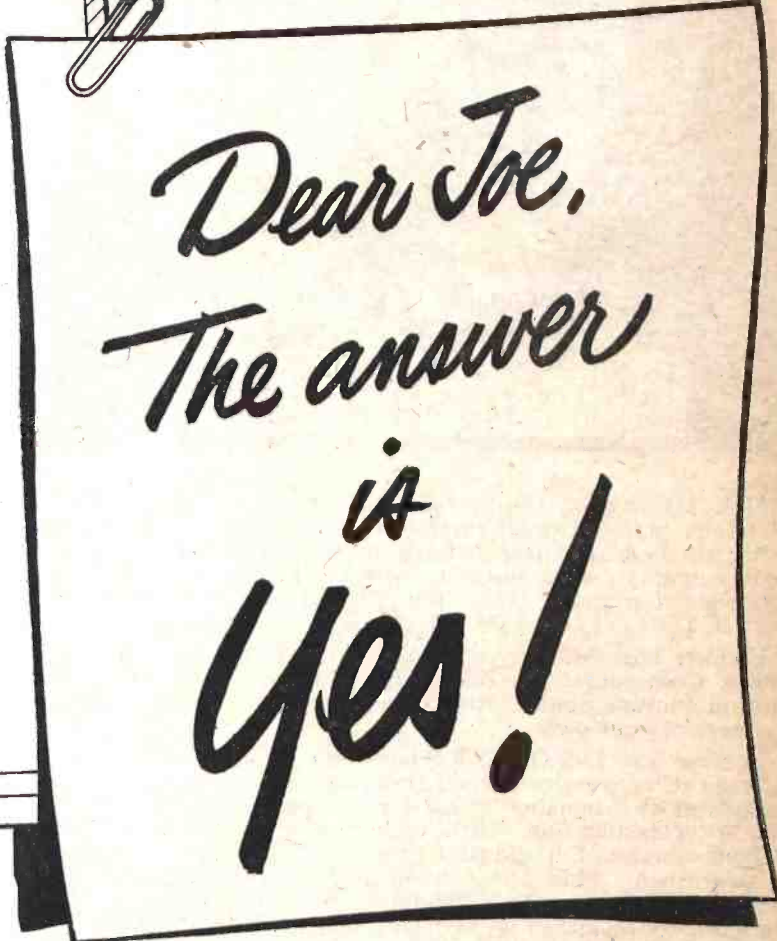
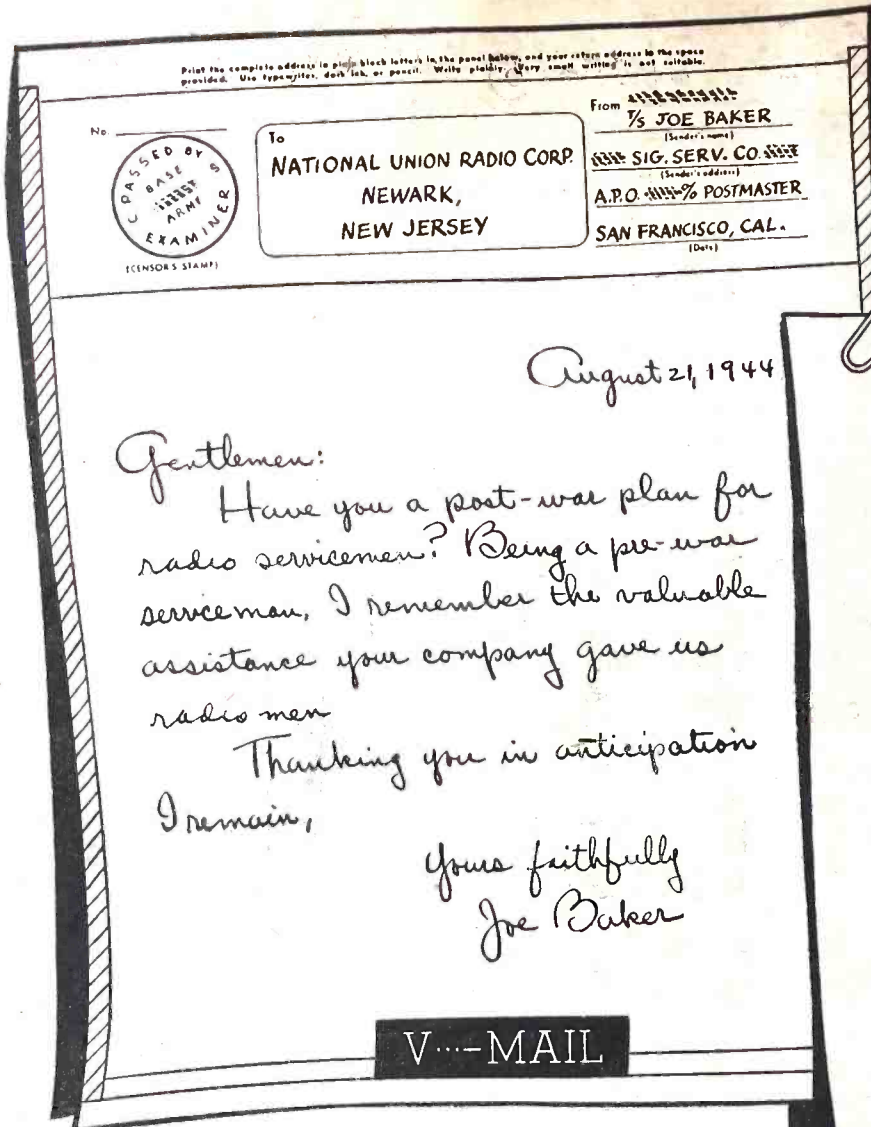

YES—and this National Union post-war plan for radio service men will be a bigger, better plan, with more of everything it takes to help you equip your shop and get the service business of your community.

Yes—from National Union you will again be able to get the finest shop and testing equipment on the famous N. U. Plan and we will make it even easier for you to get it, than before the war. There will be more free N. U. Technical litera-

ture—more advertising—more of those simplified forms and records to help you manage your business and make every possible dollar of profit out of it.

Yes—you can count on N. U., with its greatly increased resources, for more of everything you need. Count on National Union—“After the War, MORE than Before!”

NATIONAL UNION RADIO CORPORATION, NEWARK 2, N. J.
Factories: Newark and Maplewood, N. J.; Lansdale and Robesonia, Pa.



NATIONAL UNION

RADIO AND ELECTRONIC TUBES

Transmitting, Cathode Ray, Receiving, Special Purpose Tubes • Condensers • Volume Controls • Photo Electric Cells • Panel Lamps • Flashlight Bulbs

MAKE MORE MONEY

IN
Radio TELEVISION & ELECTRONICS

Now!

GET THESE 3 BOOKS

FREE!

You men already in radio know how great the demand is for trained, experienced service men, operators and technicians. You know how fast the field is growing and how important it is to keep up with developments—FM receivers, television, electronics.

Or even if you are merely INTERESTED in radio as an amateur, you must recognize the WONDERFUL OPPORTUNITY right within your grasp to cash in on your natural talent. Make it pay dividends. Get into the EXPERT RADIO SERVICE Line. Be a TELEVISION specialist—OWN A BUSINESS OF YOUR OWN. Fill out and mail the coupon below for all the details.

**Get the Latest Inside Information—
Trade Secrets by**

SHOP-METHOD HOME TRAINING

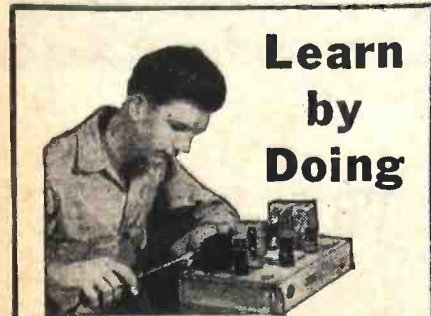

Learn by Doing

Use Actual Radio Equipment
Furnished With Your Course

Experience is the best teacher. You learn by experience with the exclusive National Shop-Method of Home Training—actually build many circuits and do experiments with the big kits of standard radio parts included in your training equipment at no extra cost to you.

In the course of your study you actually build various types of receivers—a powerful superheterodyne, a signal generator, an audio oscillator and others... You make tests and conduct experiments that show you the why and how of things. You understand what makes the various elements of electronics operate because you actually see them work for you. Not only do you gain a marvelous actual experience by this method of learning but you have valuable equipment you will use on the job in the practice of your profession as an electronics expert. Mail the coupon and learn what this means to you.



Now the famous National Schools brings its exclusive Shop-Method of training right in your own home. You can learn the most up-to-date, approved projects, systems and hook-ups step by step in your spare time. This is the sound, practical training you want and need—the development of experienced instructors working with thousands of students right in the shops and experimental laboratories of National Schools—one of the most advanced trade educational centers of the world.

This is the MODERN SYSTEM OF TRAINING. It matches the rapid progress constantly being made in radio, television and electronics. It is TIME TESTED too. National Schools has been training men for more than a third of a century. In essence this is the very same training that has helped thousands to more pay and greater opportunity.

You owe it to yourself—your future—to read the book "Radionics"—FREE to you when you send in the coupon.

National Trained Men Now Making the Best Money in History

The real value of National Training shows up in the quick progress our men make on the job. Joe Grumich of Lake Hawatha, N. J., turned down a job most men would welcome. He writes: "My latest offer was \$5,800.00 as radio photo engineer, but I am doing well where I am now engaged. I am deeply indebted to National."

Ely Bergman, now on Station WOR, told us: "My salary has been boosted considerably and at the present time I am making over \$3,000.00 per year, thanks to National Training." And from the far-off Hawaiian Islands, Wallace Choi sends this: "I am averaging \$325.00 a

month. I will say that I honestly owe all this to the excellent training I had at National." National is proud of the progress graduates are making all over the world. Read about their records yourself in the books we send you FREE.

Make Extra Money Right from the Start

You get ahead fast with National Training. Many beginners make good money on the side fixing radios and doing service work. You can turn your knowledge into cash after the first few lessons. Progress is rapid. You can actually SEE YOURSELF GET AHEAD, because the National Shop Method is so sound and practical.

Now, right now, is the time to grasp the opportunity of today—a successful career for tomorrow. Get into the big money, rapid advancement, a position of importance. A BUSINESS OF YOUR OWN. Radio, television and the whole field of electronics invites you. The industry is crying for trained men everywhere. A rapidly expanding industry—probably the greatest in history—holds out the promise of a rich future—prosperous security.

Train While You Are in Service

Prepare, right now, while you are in uniform, for a glorious secure future in the field of radio and televi-

1. A complete catalog describing the industry and the extensive training facilities of National Schools.

2. You receive a sample lesson illustrating the modern "Shop Method" instruction technique.

3. The vast opportunity field of Electronics, "The Dawn of a New World," is revealed in this fully illustrated book recently published.



sion when the war is over. Make good use of your spare time by taking your National Training now. Men in our armed service, or about to enter, get better ratings and more pay almost right from the start if they are trained in radio, television and electronics. The government needs experienced men in nearly all branches of the service. Prepare for present advancement and a sound future. Learn how easy it is the National way. We are so enthusiastic because we have seen the marvelous results of National Shop Method Home Training. Send in your coupon today and see for yourself.

NATIONAL SCHOOLS

LOS ANGELES 37, CALIFORNIA EST. 1905



MAIL OPPORTUNITY COUPON FOR QUICK ACTION

National Schools, Dept. 12RCR

(Mail in envelope or paste on penny post card)

4000 South Figueroa Street, Los Angeles 37, California

Mail me FREE the three books mentioned in your ad including a sample lesson of your course. I understand no salesman will call on me.

NAME AGE

ADDRESS

CITY STATE

Include your zone number

FREE LESSON INCLUDED

Examine the exclusive National Shop Method of Home Training. See for yourself how sound and practical it is. Be convinced that you can learn radio—electronics, television—quickly and easily in your spare time. You can't tell until you try. This trial is ABSOLUTELY FREE. And you may keep all the valuable material we send you without any obligation of any sort. Fill out the coupon immediately while you are thinking about it and drop it in the mail at once.

Thousands of men in the Army, Navy and Coast Guard have trained at National under U. S. Government sponsorship. You are the man who must be satisfied. Mail the coupon here for the three books that tell you the complete story of the marvelous new system of training in radio electronics and television. Learn the facts of this exclusive shop-method of home training. See for yourself! DECIDE FOR YOURSELF! No salesman from National Schools will call on you.

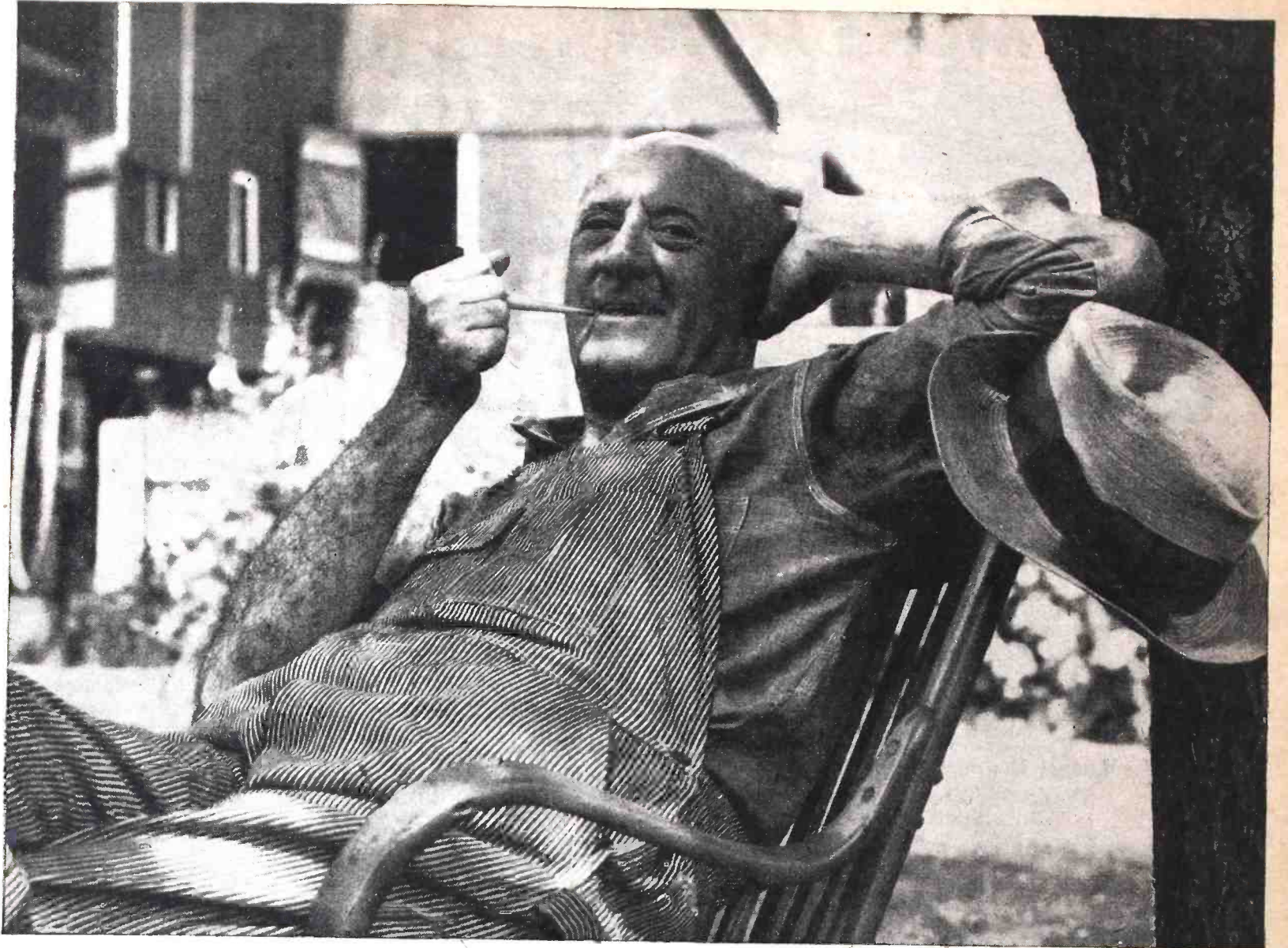

Perhaps I'm one war older than you are!

Believe me, after the last war I saw what happened. Will you let me give you some advice?

If you've got a job today—for your own sake, fellow, be smart! Think twice before you fight for a wage increase that might force prices up and land you behind the eight-ball in the end.

Salt away as much as you can out of your present wages. Put money in the bank, pay up your debts, buy more life insurance. Above all, put every extra penny you can lay your hands on into Uncle Sam's War Bonds—and *hold 'em!*

Nobody knows what's coming when the Germans and the Japs are licked. Perhaps we'll have good times. Okay. You'll be sitting pretty. Perhaps we'll have bad times. Then they're sure to hit hardest on the guy with nothing saved.

The best thing you can do for your country right now is not to buy a thing you can get along without. That helps keep prices down, heads off inflation, helps to insure good times after the war.

And the best thing you can do for your own sake, brother, if there *should* be a depression ahead, is to get your finances organized on a sound basis of paid-up debts—and

have a little money laid by to see you through!

4 THINGS TO DO to keep prices down and help avoid another depression

1. Buy only what you really need.
2. When you buy, pay no more than ceiling price. Pay your ration points in full.
3. Keep your *own* prices down. Don't take advantage of war conditions to ask for more—for your labor, your services, or the goods you sell.
4. *Save.* Buy and hold all the War Bonds you can afford—to help pay for the war and insure your future. Keep up your insurance.



U. S. Robot Bombs

. . . . Robot-remote controlled weapons are finally being built by the U. S. and will be an improvement over the Nazi prototype. Television control is foreseen to [make them] a strictly military weapon

HUGO GERNSBACK

FOR many years technicians, radio engineers, and the present writer have advocated remote controlled weapons of different types for war purposes. Long before World War II and for the past four years the writer has advocated time and again that we should build such weapons. These recommendations all fell on deaf ears.

It remained for the Nazis to engage effectively in the manufacture of various robot weapons, all of which had been anticipated. There are few technical secrets in the various German robot weapons that had not been thoroughly discussed in the technical press in the U. S. for many years.

Belatedly now, the U. S. has finally taken up the active manufacture of such weapons, foremost among them being a copy—with improvements—of the Nazi's robot flying bomb which raised so much havoc in England, particularly in London.

Late in October it was announced that a number of U. S. war plants* had already started the manufacture of rocket bombs with certain improvements for the better flight direction of the robots. Over 2,000 of these rocket bombs have already been manufactured merely for "test purposes," but it is understood that production will soon go into high gear and that huge quantities will be turned out.

The only novel thing about the German design was the rocket propulsion motor—and this itself, was of course, no new principle, but the Germans have added certain refinements. In the nose of the bomb there is a magnetic compass with electric attachments which steers the flying bomb on its course. Other refinements were added to allow for wind drift, sudden gusts of cross winds, rain and other eventualities. Even these technical developments did not make for accuracy in aiming the Nazi bomb from a distance at a specified military target. The best the Germans could do was to aim the bomb at a distant city where it was sure to cause a certain amount of destruction. Then the Nazis figured, if a sufficient amount of bombs were fired, the law of averages would insure that more than one military target would be hit. The robot V-1 bomb never had an accuracy of more than several miles, plus or minus. But on a huge target such as the city of London, prac-

tically every bomb which exploded was sure to destroy some buildings, houses, bridges, etc.

If the Nazis had developed an accurate flying bomb that could be aimed from a distance at an exact point, say a railroad station or a power plant, then they would certainly have been in a position to delay the June 1944 invasion into Normandy a great deal. The Germans had a pretty clear idea where the U. S. and other Allied concentrations of invasion matériel were located. If some of these depots had been hit, untold damage could have been done and it would of a certainty have delayed the Allies' invasion.

But the Nazis had no such weapon. They were content to let the bombs fall where they might with this exception: Every tenth robot bomb contained a radio transmitter which was in action either during the entire length of the flight of the bomb, or it could be turned on just a few seconds before the bomb struck. These radio transmitters were used merely as a check, so by simple triangulation methods the Nazis could plot the EXACT spot on which that particular bomb exploded. This gave the distant enemy operators at the launching-ramps very accurate information where the bombs struck; then corrections could be made for the next following ones. This seemed to have worked out fairly well because the end result proved that the robot bomb certainly created a fearful amount of destruction in the city of London.

It is to be hoped that when the United States forces begin using the American version of flying bomb that it will be much improved so that it will not remain the notorious Nazi terror weapon, but that we will have a strictly military weapon instead.

The writer has mentioned this reasoning many times on this page and it is to be particularly noted that today we have the means to fashion an accurate military weapon and take it out of the terror class. Senseless destruction of civilian dwellings and killing people indiscriminately as was the case of the Nazi robot bomb does not win wars. Indeed, the bombardment of London by these terror weapons stiffened the determination of the British to such an extent, that those in England who were advocating a soft peace for Germany, now are rabid in clamoring for revenge. (Continued on page 183)

Radio Thirty-Five Years Ago

In Gernsback Publications

HUGO GERNSBACK

Founder

Modern Electrics	1908
Electrical Experimenter	1913
Radio News	1919
Science & Invention	1926
Radio-Craft	1928
Short-Wave Craft	1930
Wireless Association of America	1936

The Colin & Jeance Radiophone, by the Paris Correspondent *A. C. Marlowe*.

Some of the larger libraries in the country still have copies of Modern Electrics on file for interested readers.

FROM the December, 1909, issue of MODERN ELECTRONICS:

Television and the Telephot, by *Hugo Gernsback* (first technical article in print which used the word *television*.)

Airships and Wireless Telegraphy, by *Berlin Correspondent*.

Detectors, by *George F. Worts*.

Heroes of Wireless Telegraphy.

Secondary Coil Impregnation, by *C. C. Whittaker*.

Bi-Polar Selective (Radio) Switch, by *Walter K. Keever*.

Automatic Wireless Signaling (Ducretet, Paris, System).

New Marconi Spark Gap.

The Construction of an Efficient Aerial, by *Geo. F. Worts*.

The Measurement of Electric Waves, by *M. M. Deviny*.

Wireless Switch.

A Silicon Detector, by *James D. Thomas*.

Radio-Electronics

Items Interesting

PLASTIC lenses, plus a new principle in television, will give the post-war television receiver owner much bigger and brighter images at a low cost. So report Loury Maloff and David Epstein of the Radio Corporation of America, in a paper read before the first National Electronics Conference, held at Chicago last October. According to the RCA engineers, the new system provides a seven-to-one gain in the percentage of light delivered from the tube to the screen, as compared to the conventional projection lens now used for the purpose.

The system includes a spherical front surface mirror and an aspherical lens. The mirror—shown at A in the drawing—reminds one of those used in giant astronomical telescopes. The special lens is at B. One side is flat, the other rises slightly at the center and at the edges but is depressed in the intermediate area. In optical language, the surface contour renders the lens optically positive in the center, with a gradual change to negative in the outer portions.

The television tube, C, is inserted through an opening in the center of the lens. It projects its image to the mirror, which reflects it back through the aspherical lens to the plane mirror, D, and onto the screen, as shown by the dotted lines. The lens corrects spherical aberration produced by the mirror and focusses the image.

The great light-gathering power of this system results in a much brighter image for any given amount of enlargement, as compared with older projection systems.

Probably most interesting to the prospective viewer is the news that the lens—which might be prohibitively expensive if ground from a glass blank in the ordinary manner—is molded from a clear plastic material. This comparatively inexpensive process, says RCA, will make it possible to use the system in medium-priced home television receivers.

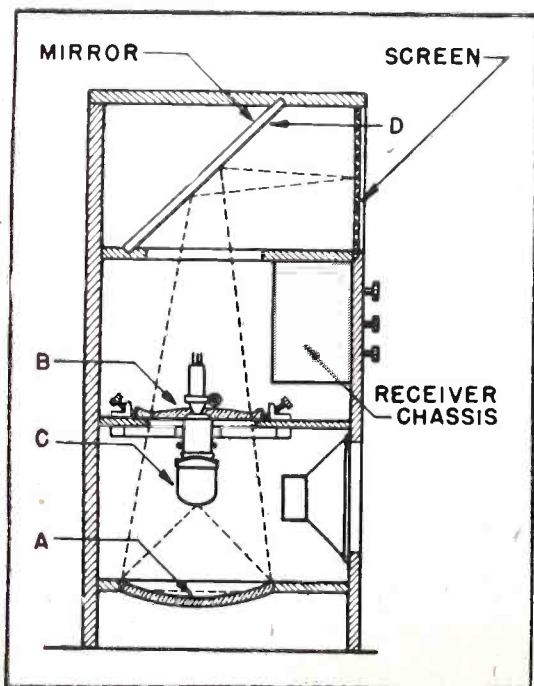

GLASS land mines are being used by United States forces in Europe to foil enemy electronic locators and electronic mine detonators, Colonel J. G. Shouvin, chief of the Cincinnati Ordnance District, disclosed last month.

Known as the M5, the new non-metallic mine was a closely guarded secret for many months. It is of the type which is effective against tanks, trucks and other vehicular weapons with a high contact pressure, according to information released at present.

SWEDEN is beginning construction of two new high-powered radio transmitters to increase the radio efficiency of that country, according to a British report last month. Each one will have a power of 100 kilowatts.

One of the stations will be used for home broadcasting, the other for directional short-wave transmissions to Swedish nationals abroad. Good results are expected from the new station, as the old short-wave transmitter at Motala, with a power of only 12 kilowatts, was received with fair consistency in many parts of the world.

JAMES LAWRENCE FLY chairman of the Federal Communications Commission, resigned his post November fifteenth. He had served on the FCC since July 27, 1939, and had previously been in Government service since 1929, first as special assistant to the Attorney General and later as general counsel of the TVA. It was while serving in this latter capacity that he was referred to by the late Wendell Willkie as "the most dangerous man in the world—to have on the other side!"

The FCC chairman's announcement of his intention to return to private life coincided with the closing of hearings on post-war frequency allocations, leading to the belief that he may have delayed his retirement to private life until the FCC allocation plan could have been completed.

The last years of Mr. Fly's chairmanship were colorful and controversial, and he was at odds at one time or another with large divisions of the radio industry, as well as certain sections of Congress. Winning the decision in most of such contests, he aroused the respect of opponents and the admiration of spectators by his imperturbability and love of heated debate.

Mr. Fly will resume private law practice with the New York firm with which he began in 1926.

EUROPE will require five million American radio receivers immediately after the war, according to a report in *Time* last month.

This hint to the American radio industry came from Arno Huth, of the Geneva Research Center. The European industry will be unable to fill the demand for home broadcast receivers, believes Mr. Huth, because of injuries suffered during the war.

Asia, he estimated, would require about two million receivers, but their demands "might skyrocket within a few years to 20 million sets."

EDUCATIONAL station WBEZ, FM outlet of the Board of Education, Chicago, put 385 hours of programs for school classes on the air during the second semester of the 1943-44 school term, according to a recent report.

The 161 schools reached by the programs possess 1,226 radios, and have an audience of 263,561 students.

RADIO-EQUIPPED homes have increased by 3,700,000 since April 1940, according to a survey issued last month by Columbia Broadcasting system. Research department of CBS explains the increase in the face of the 1940 "freeze" on set production. Thirteen million radio sets, they state, were manufactured in 1941, and some thousands of sets which had been secondary receivers in homes with two or more receivers changed hands. Many of these became primary sets in new radio homes.

The survey "U. S. Radio Ownership" which was released for the benefit of persons interested in the radio market, gives detailed information on population, families and radio ownership in each of the States, with totals for several geographic areas.

MORE FREQUENCIES for broadcasting was urged by Paul Godley, consulting engineer and famous old-time amateur, at a dinner of the Federal Communications Bar Association last month.

He proposed three new channels at the lower end of the present broadcast band. Frequencies suggested are 520, 530 and 540 kc. Only low-powered stations would be licensed to operate in these bands, to obviate all possibility of interference on the important 500-kc distress band. Mr. Godley believes that 150 services could thus be accommodated in areas at present inadequately served.

ELECTRONICS holds the key to the "all-weather transport plane" and the long-sought airline goal of 100 per cent completion of flight schedules. This opinion was expressed last month by G. M. Williams, Senior Vice President of the Curtis-Wright Corporation, in opening the 1944 series of civic-sponsored aviation forums.

"Electronics," he said, "will enable the flight dispatcher and the airliner crew to 'see through' fog and rain and cooperate in safe, on-schedule landings. This will eliminate disruptive weather effects which previously have held air travel to a record of 91 per cent completion of scheduled operations."

PROGRAM COSTS may confine television to the larger cities for some time, President Lewis A. Weiss of the Don Lee Broadcasting System told the FCC last month.

Television costs, he pointed out, are much higher than for FM or standard radio, and approach those of regular theater productions. These costs would limit television stations to cities of 500,000 population or more. About 10 per cent of the residents of such cities, he thought, would see the broadcasts regularly.

No statement as to the effect of satellite or relay stations on such costs was made by the Don Lee president.

Monthly Review

to the Technician

TUBERCULOSIS, it was revealed at a national meeting of X-ray specialists last month, is now being attacked with the help of the electron tube.

The device is used in connection with a new technique of X-ray chest examination, which makes practical the photographing of every possible chest in the country. The X-rays are projected on a fluorescent screen. The resulting image can then be photographed with ordinary light, using cheap 35-mm camera film if convenient. The older method of taking the picture direct by X-ray on a 14 x 17-inch film was slow and tremendously more expensive. With the new method, many more X-ray chest examinations—so valuable in discovering early tuberculosis—can be made.

The electronic gadget was invented by Dr. Russell Morgan of the U. S. Public Health Service. It is a special type of exposure meter which measures the amount of light falling on the negative from the fluoroscope, and shuts off the X-rays when the negative has been properly exposed. By the use of the Morgan timer technicians untrained in photography can take X-ray pictures at the rate of five per minute with the assurance that every one will be a perfect job.

NYLON will be used for insulating radio wires in the post-war world, according to a report released last month by du Pont de Nemours Co.

The problem, according to Dr. J. W. Shackleton of the Plastics Department of that concern, has been to develop a nylon that can be extruded in standard equipment at temperatures attainable by present commercial wire-coating processes. The new compound can be used in such equipment and coatings of less than one mil in thickness have been applied.

Nylon has a number of outstanding properties for wire coating. It is fire-resistant, and when ignited by a free flame extinguished itself after the flame was removed.

Another plastic which has already won a name for itself as an electric insulator is polythene, Dr. Shackleton pointed out. With its power factor of .0002 to .0003 and a dielectric constant of 2 to 3, it has been welcomed by the cable industry. The entire present output has been pre-empted by the Armed Services for use in cable insulation or in other critical electrical items.

RADIO workers in the Philips plant at Eindhoven, Holland, mass-produced underground radio sets under the occupying Germans' noses, according to a British broadcast last month.

The receivers were made in small cracker boxes with parts "snaffled" from the factory. Thus was the confiscation of all radios—which the Nazis put into effect in all occupied countries—circumvented. Such confiscation, said the broadcast, was almost meaningless in a city "where almost every other man is a radio engineer."

CIVILIAN and military requirements for radio receiving tubes after Germany's defeat will still be 60 or 70 per cent higher than present maximum production rates, according to a War Production Board statement last month.

Military requirements for receiving tubes now average 10,000,000 tubes per month. This was about equal to the total U. S. production for August. The end of the European war will reduce military needs slightly, but not until one year after Germany's defeat is a 45 per cent cut in such requirements expected, WPB officials said.

At present, approximately 13 per cent of total radio receiver tube production is available to civilians for replacement purposes only. Without question, much larger quantities of tubes could be absorbed without noticeably lessening the present shortage.

X-RAY pictures through foot-thick pieces of steel can now be taken with a new 2,000,000-volt mobile X-ray unit just developed by General Electric. First announcement of the new high-voltage device was made last month by Dr. Ernest E. Charlton of the G-E Research Laboratory at Schenectady.

Up to now the most powerful X-ray unit in general use has been the million-volt apparatus developed in the G-E laboratory. More than 50 of these are now actively serving the war effort in the United States and abroad.

In radiographing an eight-inch steel casting the two million-volt outfit is 78 times as fast as the million-volt. Under one typical set of conditions cited by Dr. Charlton, four and a half hours were required to make an exposure through this thickness with a

million volts. Two million volts did it in three and a half minutes. For still thicker sections the ratio is even greater. Two-million-volt X-rays make a satisfactory exposure through a foot of steel in about two hours at a distance of three feet from the end of the tube. For practical purposes such a thickness is opaque to million-volt X-rays.

The two-million-volt apparatus was constructed with the assistance of the engineering staff of General Electric X-Ray Corporation. Like that of one million volts, it makes use of a multiple-electrode tube, in which the electrons, starting from a heated filament at the top, are speeded in stages until they have the total rated energy. After they attain full speed, which for two million volts is about 179,000 miles per second or 96 per cent of the velocity of light, they strike a copper-backed tungsten target at the end of the tube and X-rays are generated. These may either be squirted from the end, like water from a hose, or sprayed from the side. After penetrating the metal specimen, they fall on photographic film which makes the radiograph.

In the million-volt outfit the electrons, on their way to the target, were speeded up in twelve steps, but the new tube has 24, averaging 83,500 volts at each stage. Construction of the tube was made possible by the use of rings of fernico between the sections of glass. Fernico is an alloy which expands with heat the same as glass, and so the metal and glass can be fused directly together.

High voltage is supplied by a resonance transformer, invention of Mr. Willem E. Westendorp, who collaborated in the development of the 2,000,000-volt tube. Unlike the usual transformer, this has no iron core and the X-ray tube is placed at its axis. Both tube and transformer are in the closed metal tank, five feet in diameter and eight feet long, which contains Freon gas (dichlorodifluoromethane) for insulation.

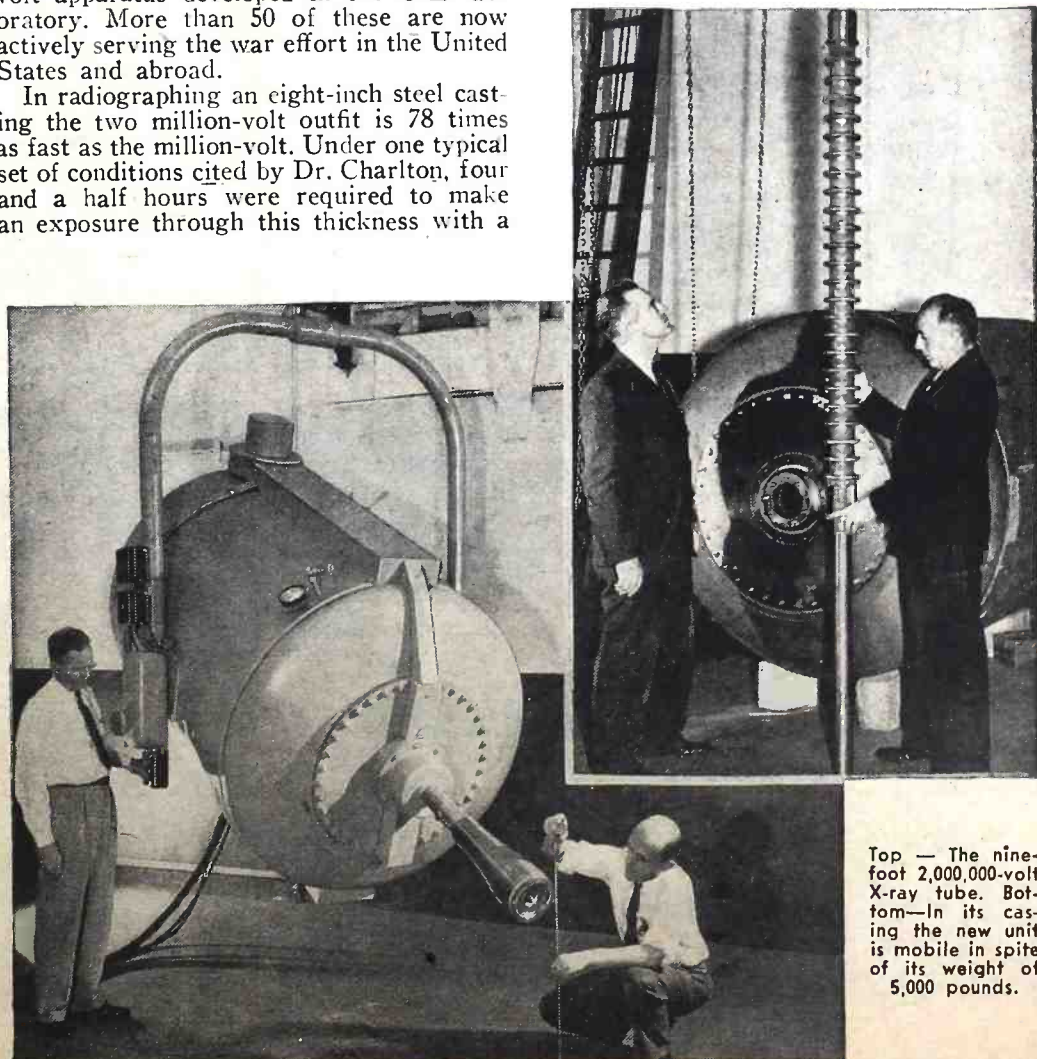

Top — The nine-foot 2,000,000-volt X-ray tube. Bottom—In its casing the new unit is mobile in spite of its weight of 5,000 pounds.

1944—Television's Year

TELEVISION'S record for 1944 has been astounding (despite irksome restrictions on talent and materials) both from the viewpoint of the technician and showman.

Vitality of the art was shown by the thunderous reaction to the CBS proposal for fine-grain, wide-band television after the war. Condemned by some at the time as being possibly detrimental to the industry's future, it did more than any other one thing to focus public attention on television as an immediate issue instead of a development of the vague future.

It is now apparent that there will neither be a "freeze" on present designs, nor long delay while new spectra are explored. Future policy—as seen today—will be to combine the desirable propositions forwarded by both parties to the discussion, with the object of creating as little present or future dislocation as possible.

Advances in the design of equipment have been great, though many of them cannot now be publicized. The concept of satellite and relay stations, released at the beginning of the year, answered many questions about the economic practicability

of television, with its high program cost and limited range for any one station. Steady progress throughout the year has been capped by the announcement of plastic lenses which will make projection of large television images practical.

The year was no less important to the producer of television spectacles. Spurred by the necessity of mastering technique for post-war expansion, experiments and advances were made in all branches of television production. Notable among these were the broadcasting of the Democratic and Republican political conventions and the telecasting of a full-dress musical comedy, written and produced expressly for television. These feats were only the highlights of a year's progress which may cause future producers to date the television art from 1944.

The illustrations on this page, although some of them pre-date the year, show the present level of television's accomplishments. 1944 has pioneered, opened new territory, resolved doubts and cleared a path. 1945 should benefit from the spade-work of its predecessor, and its progress should be registered in geometric terms.

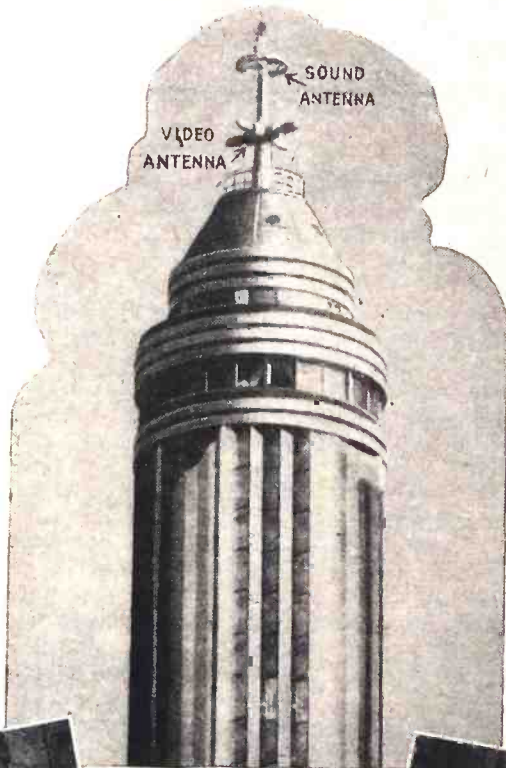

NBC photo

BBC's television antenna. Top circle is sound antenna, lower cross a video radiator.

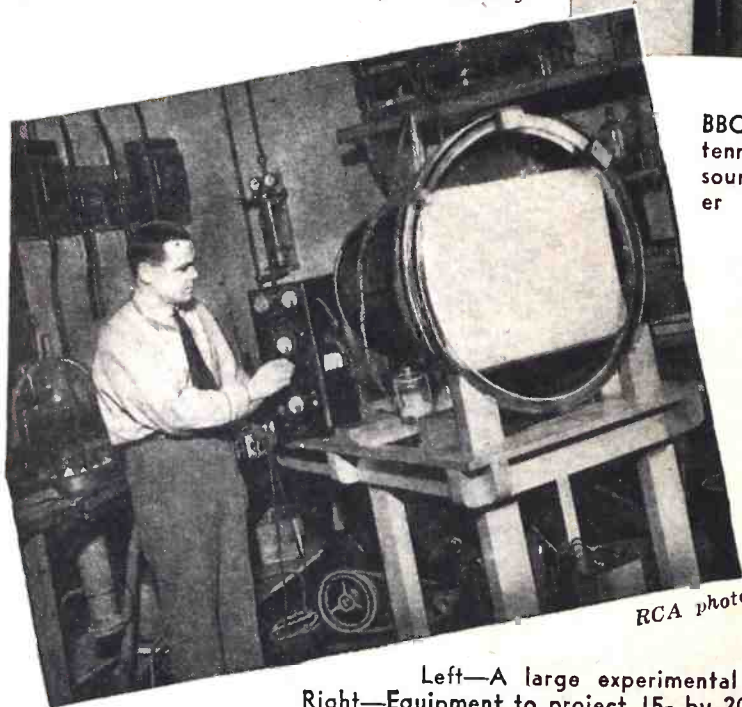

RCA photo



RCA photo

Left—A large experimental 18- by 24-inch viewing Kinescope. Right—Equipment to project 15- by 20-foot images in a theater television demonstration.

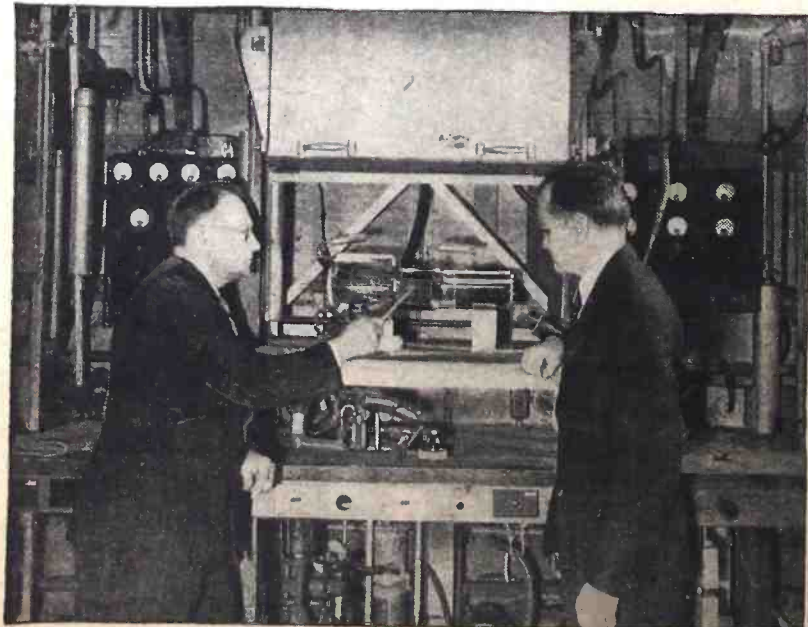

RCA photo

Dr. Zworykin explains features of a new experimental Iconoscope.



Courtesy Television Productions Inc.

Television and the news. An illustrated commentary at Radio W6XYZ.

MARINES AND RADIO

Servicing Problems Complicated by Conditions in South Seas

By CPL. ERNIE HARWELL AND 1ST LT. CYRIL D. JEFFCOAT, U.S.M.C.

TAKE it from Marine communication experts in the Signal Battalion at Camp Lejeune, N. C., radio troubles are alike everywhere, but they're more acute in the moisture-laden atmosphere of the Pacific isles.

Over there, in addition to battling Japs, the boys have to contend with two dreaded enemies of radio—moisture and salt water.

To keep sets dry, according to Marine Master Technical Sgt. Pearre J. Davenport, radio men in the Marshall Islands used to burn electric light bulbs in their sets at all times. Davenport also used to wipe his equipment constantly with either vinegar or a mixture of kerosene and water.

"That was the only way," he explained as he worked on a radio in the camp maintenance shop here, "to keep the chassis from rusting away."

Marine 2nd Lt. Robert J. Greenway, who is officer in charge of telephone school at Camp Lejeune, found that a growth of fungus on his wires was a major problem in the South Pacific. The trouble was hard to combat at first, but later it was mollified through the use of protective lacquer on the wires.

Other Marines have used tin cans for tube shields and beer-bottle necks as substitutes for insulators. They have rebuilt bullet-riddled sets and salvaged many which have been ruined by salt water.

AFTER AN OCEAN DIP

"To save those which had been in salt water," explains T/Sgt. Lloyd L. Whiteley, now an instructor in radio school here, "we gave them a special ultra-violet ray treatment at the repair shop of the Signal Supply Section Depot, San Francisco. This dried them out. Then salt crystals could be blown off, and the sets thoroughly cleaned. The next step was spraying the equipment with lacquer which is non-conductive and resistant to moisture."

Whiteley, who was non-commissioned officer in charge of the repair shop at San Francisco, had about 50 Marines and civilians working under his watchful eyes. His crew was divided according to the type work—testing, repair, and manufacturing.

From San Francisco, Whiteley came to Camp Lejeune with a thorough knowledge in the problems radio men face overseas. He is utilizing his background as he teaches a special class of Dutch Marines the fundamentals of combat radio in a 10-week course here.

At San Francisco, Whiteley learned many tricks. For instance, the boys had been wearing out their leads in the big, \$150 tubes. Not knowing how to repair them, they discarded the old tubes. Once a tube was sent to Whiteley's shop. The men there experimented and found a way to fix the tube by spot welding new leads into it.

The men also learned that peanut tubes would not stand combat punishment and strafing; and a good many units found cables giving trouble because of jarring and shorting.

Marine 1st Lt. Cyril D. Jeffcoat, Signal Battalion Plans and Operations officer, while on Samoa made use of an empty

beer can as a shim in a one-third horsepower fan for three weeks to keep the fan blade on and the tubes cool. Another time he and determined Leatherneck signalmen of his unit rewound a transformer producing 2000 peak volts on the secondary. To do this, it was necessary to heat and dry in orange shellac in an oven. A few of his observations follow:

"Improvise," "procure," and "promote" are the three most important words in the vocabulary of a combat communication maintenance man. The Skipper once told me that to counter-ask him a question as to where to obtain the materials necessary to perform an assignment was to give him "guff." All he was interested in from beginning to end was having his orders—or the one who received them—carried out. To accomplish the former and thus prevent the latter, it was often necessary to make "minor adjustments" in some Engineer's design—after all, the Engineer merely depends on his equipment for his living; we depend on it for our lives. Not only did we have to make "minor adjustments"—we sometimes had to go so far as to THINK.

On the other hand, "sympathy" is a word inserted in Webster's only to help sell the dictionary. All the "Old Man" wanted was results and plenty of them. Now comes the sixty-four-dollar question: What are you going to do at three o'clock in the morning when you get a personal invitation from the General to get on the air and I don't give a damn how you do it when every rectifier tube on the island is shot?—SOMETHING'S gotta give; something that they forgot to tell us about back in school. IF's don't count. You've gotta get on, or get off.

PROCUREMENT AND PROMOTION

Then you remember that incident when you were a kid in the backyard playing with Dad's 200-watt trouble lamp and it fell from where you laid it and broke the filament. How you have picked it up and shook it until the filament touched and the current had fused the filament together.

By this time you have already "procured" an auto-transformer and are applying a slightly-higher-than-normal filament voltage to the filament and shaking the tube like a snake charmer until the filament has touched and welded itself together again. Saved by the bell! You have now "promoted" a rectifier tube.

But a Marine's troubles stop short of no one save Saint Peter himself.

Everything is working just perfect—until we need them most.

Next thing we know the overload relay in the final amplifier has kicked the plate voltage off and we are in the midst of a

program of research and experiment again.

After much deliberation, at the point where we have only three hairs left in our head and even the Comm. Officer has exposed his Engineering Degree to it without favorable results, the overload relay is still the object of much concern and little affection. Still much later some screw-driver

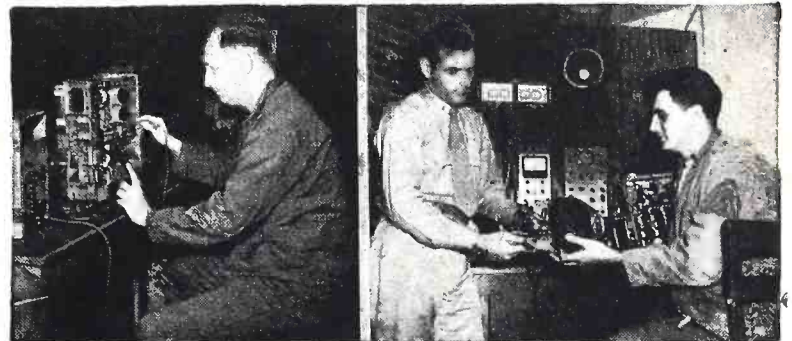

Left—Tech. Sergeant P. J. Davenport, repairman of the Signal Battalion, works on a tough one. Right—A "back to nature" model, made from salvaged parts and put into a turtle-shell "cabinet."

mechanic timidly points to a corroded grid-cap on the tube and shyly asks why aluminum turns green in the tropics.

What is there about a radio's entrails that tropical insects love so well?

STAY ON THE BEAM!

A lot of anyone's troubles, in combat as well as elsewhere, is due to their own thoughtlessness. Like the time we couldn't understand why the power plant quit until someone discovered we were trying to use insecticide from a 55-gallon drum for fuel. (Nor did it take the "bugs" out of the motor).

You gotta stay awake to stay in the big league!

You may have to remount your transformers in a can in such a manner that the whole thing can be submerged in oil in order to keep the moisture out. This may require a little "procuring" of salad oil cans from some unfortunate mess sergeant. Who likes French dressing, anyway?

An empty beer can and a pair of scissors facilitated the improvisation of a shim for the fan blade of an air-cooling system essential to the operation of a high-voltage rectifier tube. The blower held up under this condition for three weeks. In the meantime, another one was flown in for replacement.

Improvisation, promotion and procuring was not peculiar to communications alone, however. Many a trip has been taken in a truck we had, with an International motor, a Chevrolet cab and chassis, Ford headlights and fenders and metal body of still a different make.

In addition to keeping on the alert for ideas, one sometimes has to guard against ideas of procurement and promotion of others. It took a long time to discover the real reason for the rapid evaporation of the liquid in fire extinguishers. When CO₂ is poured gently over cans of beer, it will chill them to near freezing in a matter of a few seconds.

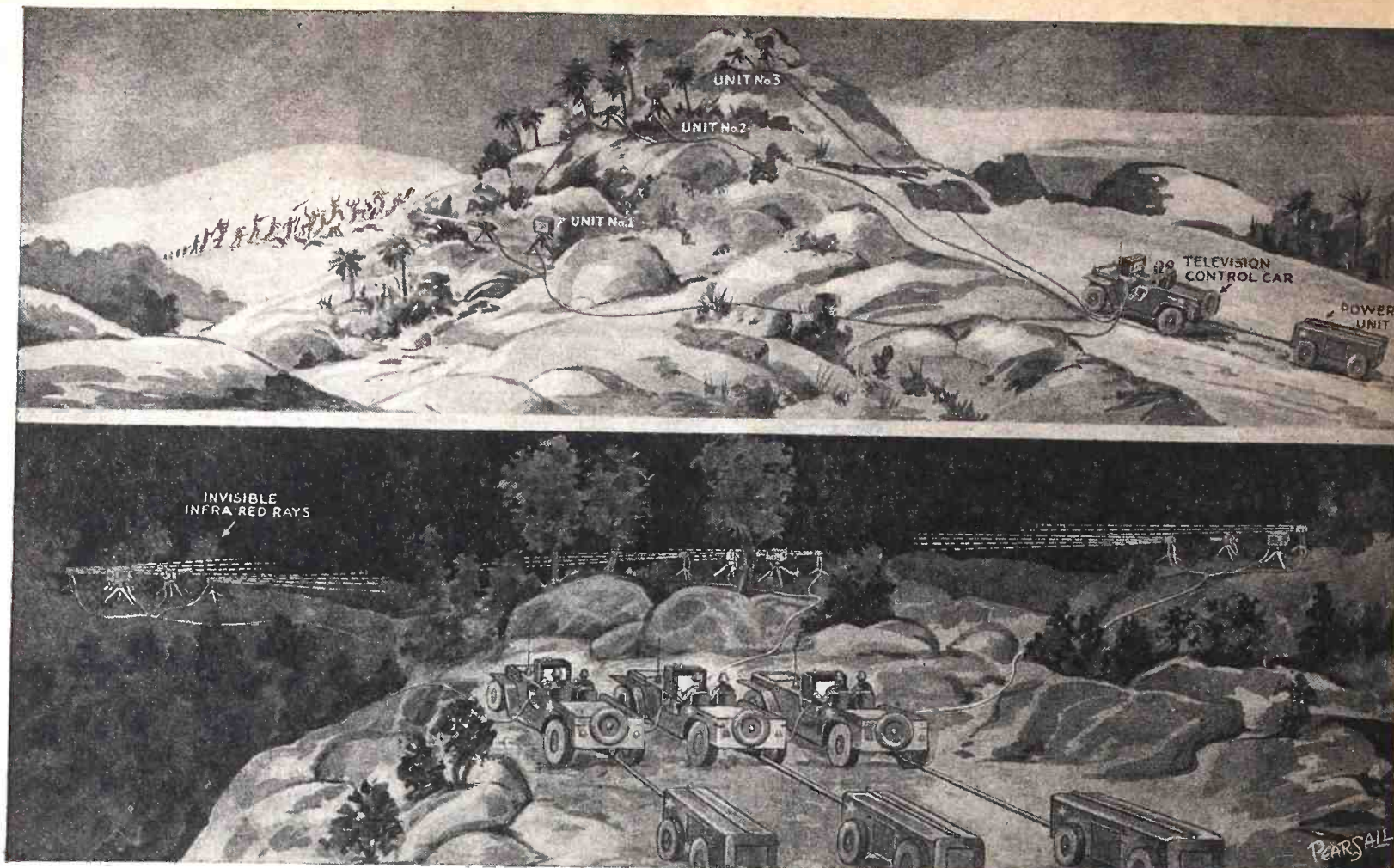

Top: Television-controlled guns lined up to protect each other and continue opposition to an enemy advance without losses to the defenders. Bottom: The proposed robot machine-gun at night. Infra-red rays, invisible to the eye, "illuminate" the landscape for the camera lens.

COVER FEATURE: Television Controlled Machine Gun

By HUGO GERNSBACK

THE outstanding tendency in World War 2 has been the desire of all military authorities of the belligerent armies to conserve human life as much as possible. Close-in fighting where casualties are high is becoming the exception on all fronts. Even such modern weapons as flame-throwers, which only a few years ago could throw a flame not more than 15 or 20 feet, now can hurl a sheet of devastating fire over 500 feet. It is so with many other devices. Military authorities constantly try to eliminate those weapons which make for high casualties.

The machine gun is one of these "high casualty" weapons, because the men tending it are vulnerable to rifle fire, hand grenades and other close-in weapons. Yet the machine gun has a high defensive value which cannot be easily dismissed, because well placed units will stop advancing infantry in their tracks—unless they succeed in wiping out the gun with its gunners.

For this reason we will outline the technique of a remote controlled robot machine gun, not personally served by a gun crew, but indirectly, from a safe distance. This makes it necessary to give the gun "eyes," so the approaching enemy can be spotted instantly and fired upon. Television is the answer to this problem. It has been graphically depicted on the front cover as well as the accompanying illustration.

The television controlled machine gun can be realized now, indeed all the technical means to accomplish it are already in

our hands. The *modus operandi* of the new weapon is as follows:

The ordinary machine gun must first be converted into an automatic gun. The ammunition is contained in cases built around it and the firing as well as the aiming is done by electrical means at a distance. All this does not present any unusual technical difficulties today. In order to aim the machine gun at the correct angle a small electrical motor is used which moves the gun barrel into any desired position. The firing is done by means of a simple electro-magnetic control.

It should be understood that both the machine gun as well as the television transmitting unit are heavily camouflaged so that they cannot be readily seen by the enemy. For purposes of better illustration the camouflage is not shown in our front cover but is on the illustration on this page.

The television transmitter is set up right behind the machine gun. Thus the transmitter will "view" or scan the field immediately in the front and to the sides of it.

Somewhere in the rear we have the television receiver and the electric power unit with its generator which supplies the necessary current for the television transmitter and receiver, as well as the power for remote control of the machine gun.

At the receiver one operator continuously watches the television screen for any suspicious motion. If the enemy approaches he immediately starts firing merely by pressing a hand control button. The opera-

tor at the right manipulates a small wheel in front of the control board. This gives the motion to the machine gun, so it can be pointed either to the right or left, up or down, as required. By watching the television screen which also shows the distant machine gun he can see exactly into what angle he must point it so its fire will cover the approaching enemy.

Suppose the enemy ambushes the robot machine gun either by rifle fire, artillery or by hand grenades, thus wiping it out. This, of course, will happen frequently but if it does no human lives are lost. Our illustration shows a further new application. There is a relay of several machine guns and several television transmitters, all connected to the same cables. Therefore, if the television controlled machine gun No. 1 is wiped out, the enemy still has to demolish the second one farther back. This probably will not happen without heavy casualties to the enemy. Any number of units can thus be rigged up. All can be operated from the same control unit. Then as one unit is wiped out, the second reserve unit is placed into circuit and the enemy still must wipe out the No. 2 position before he can reach the No. 3 position, etc. It will be seen that in this manner a machine gun "defense in depth" is created.

Our illustration also shows how the human control units are guarded. All are operated from safe positions in such a way that it will be unlikely that any remote machine gun operators become casualties.

(Continued on page 190)



1—Conductor Howard gets his orders from dispatcher. 2—Receiving orders in the yards. 3—Antenna on caboose roof. 4—Central VHF transmitter and receiver. 5 and 6—Engineer A. Miller receives radio orders.

PROBLEMS OF MOBILE RADIO

By J. H. WALLIS*

RECENT press announcements have created the impression that railroads were in a position to adopt and put into use, radio communication channels to serve a variety of needs. The picture is hardly as favorable as that. The equipment used thus far is largely emergency equipment and is not adapted for permanent use by railroads for several reasons. First, the electrical and mechanical features of such equipment do not fill the requirements necessary for the specialized type of service necessary for railroad operation. Second, and most important, that type of equipment is designed to operate on frequencies between 30 and 40 megacycles, and those frequencies are not available for unlimited service and are for the most part granted for emergency service. While having some value to the railroads, such equipment is of little value for day to day communications service. Licenses for this type equipment limits its use to "emergency" use only.

Only licenses for frequencies that will not be limited by the "emergency" provisions can meet the general purpose of radio operations and communications on the railroads. It is the opinion of both the railroads and the various government agencies, now interested in promoting the safety phase of radio use on the railroads, that

frequencies considerably higher than the 30 or 40 megacycle band will be available for railroad service if the railroads make an effort to utilize these frequencies to the best advantage. Frequencies between 100 and 400 megacycles are now being considered because there are more channels available in that region and certain technical features make these frequencies more desirable for some types of railroad services.

Up to the present time the commercial activity in the 100 to 400 megacycles region has been rather limited. As a result there are many techniques and practical problems to be solved before these channels can be put into regular everyday service. Some commercial communication networks, the Army and Navy, and, last but not least, the amateur radio organizations, proved some years ago that successful communications could be maintained on these frequencies under most of the conditions encountered in railroad service. However, there is a considerable amount of research and experiment to be done to develop types of equipment that are best suited for railroad service.

The Baltimore and Ohio is proceeding to adopt, immediately, the best equipment available to expedite the movement of war materials, and contribute to the safety of railroad operations, but at the same time we are making an exhaustive study of both the technical and operational prob-

lems involved. Technical problems are briefly determining optimum frequencies and transmitting powers, arriving at suitable mechanical and electrical characteristics to insure efficient and uninterrupted service. Operational problems are of even greater importance, because of the limited amount of experience by the railroads in this field, and require extensive studies by the operating departments to apply the use of radio to supplement existing safety measures and to expedite train movements.

These experiments by the Baltimore and Ohio in cooperation with the Radio Division of the Bendix Corporation will suggest some of the technical features necessary for successful use of radio in railroad operations, and be a guide to the manufacturer in supplying the necessary equipment. Meantime numerous departments of the railroad are cooperating in the effort to make communication a valuable tool for increasing efficiency and promoting safety in our operations.

Increased efficiency of plants now in war production plus the fact that material produced by many is the same general type of goods needed for peacetime customers will facilitate the production of peacetime electrical appliances for the public within a few months after the war's end, according to W. B. Montague, Westinghouse executive.

*Communications Engineer, Baltimore & Ohio Railroad.

EMERGENCY RADIO

By LOYAL S. FOX AND MARK BRICE*

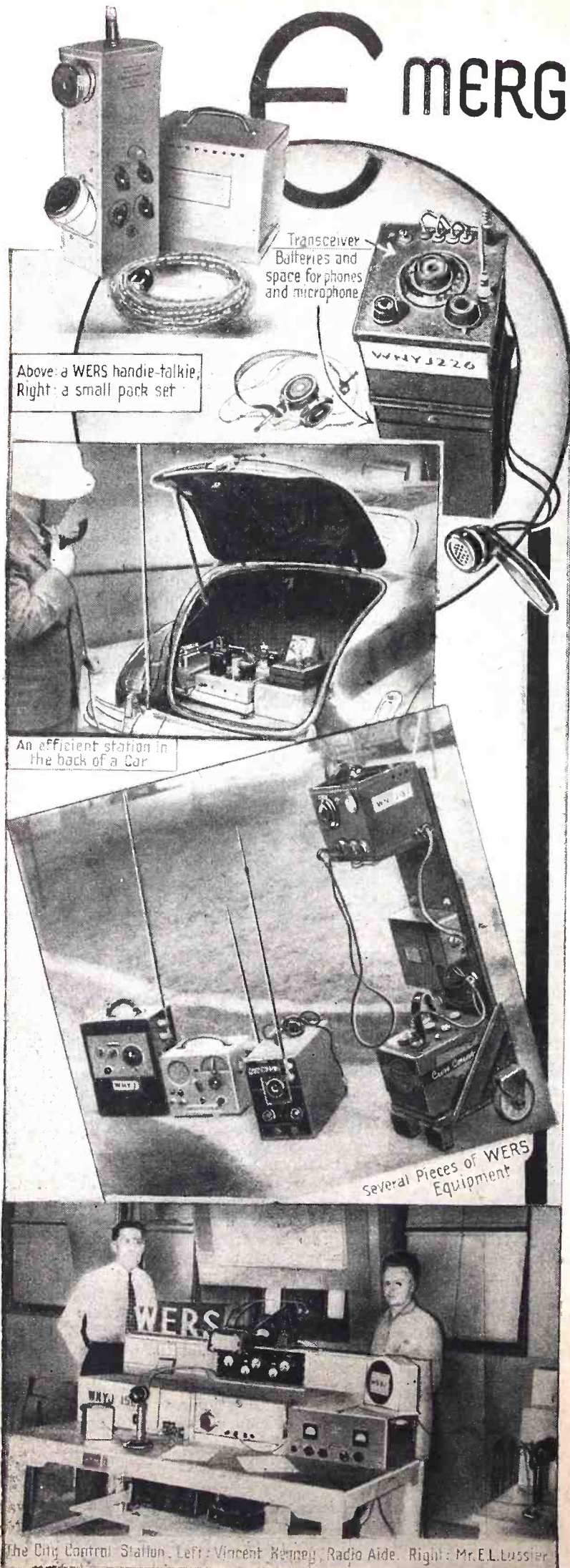

Above: a WERS handie-talkie, Right: a small pack set

Transceiver
Batteries and
space for phones
and microphone

An efficient station in
the back of a Car

Several Pieces of WERS
Equipment

The City Control Station. Left: Vincent Kennedy, Radio Aide. Right: Mr. E.L. Lussier

Photos by John Neva

THE WAR EMERGENCY RADIO SERVICE was first organized when the possibility of air raids and on the Pacific Coast actual invasion threatened. Today it is of great service to municipalities in times of local emergency. More than any other one activity, it has kept the spirit of amateur radio alive among such "hams" as are not in the fighting lines or occupied with war work.

The discipline of WERS drills has been of great benefit to participating hams, as have been the various tests—substitutes for the "Field Days" of pre-war memories. Numbers of efficient transmitters and receivers—built from practically nothing—have appeared. In New York we have one of the largest WERS in the country, with more than 300 active stations. A great variety of equipment has been used, ranging from the set thrown together early in the evening of a test to commercial low-power transmitter-receivers.

Walkie-talkies as used in the War Emergency Radio Service may be divided into two broad classifications: the transceiver and the transmitter-receiver—with the latter in the majority.

The transceiver is simpler, easier to build, and less expensive, and so is more in favor with the new constructor even though it must necessarily be a compromise.

Most transceivers consist basically of two units: an oscillator-detector and a modulator-amplifier. These are converted from transmitting to receiving by a suitable switching system. The oscillator-detector circuit most used is a simple ultra-audion (Fig. 1). When properly constructed this is a very persistent oscillator on VHF. As will be seen, there is very little difference between the transmitting and the receiving circuit; the value of the grid leak is increased from 10,000 ohms to 2 to 10 megohms—experiment will determine the best value—and the grid leak connection is changed. The .005 mfd. condenser by-passes some of the super-regenerative "rush." Almost any triode will operate, but a favorite is the 1G4GT/G.

The modulator-amplifier circuit is shown in Fig. 2. Here the input is switched from microphone to detector, and the output from oscillator to phones. The 500-ohm resistor supplies the grid bias to the modulator-amplifier tube so that no "C" battery is required. The recommended tube here is the 1T5GT.

Fig. 3 shows the complete circuit with switching arrangement which results from the combination of Fig. 1 and Fig. 2. The switch required is a four-pole, double-throw type.

The most difficult item to obtain is the combination "transceiver" transformer. Many interstage audio transformers can be converted into transceiver transformers by adding a microphone winding. Remove the core and one or two layers of insulating paper. Wind on a single layer of No. 30 enamelled wire. Give this a coat of shellac, and immediately apply a thin paper covering, which is also given a coat of shellac. When dry reassemble.

It is also possible to use the arrangement shown in Fig. 4, although the amplification is less than with the transformer, and an additional audio choke is required.

The variable condenser is a 3-plate midget, obtained by stripping plates from a larger capacity until only two stator and one rotor

(Continued on page 176)

*WERS, New York City

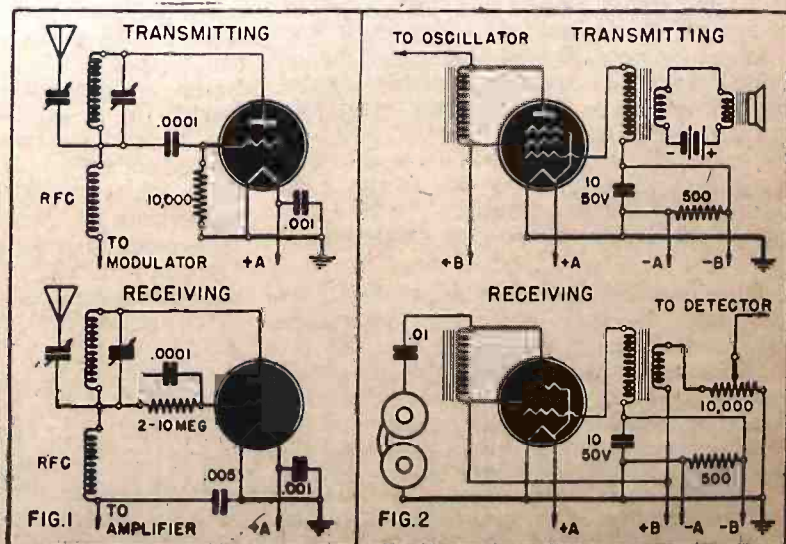

Fig. 1—Detector-oscillator tube circuit breakdown for transmitting and receiving. Fig. 2—Same breakdown for the modulator-amplifier.

BROADCAST EQUIPMENT

PART IV REMOTE BROADCAST TECHNIQUE

By DON C. HOEFLER

A REMOTE or "nemo" broadcast is any one originating at a point removed from the station's regular studios. Depending upon the type of broadcast, such a point might be a sports arena, ballroom, theater, political gathering, the middle of a public sidewalk, or almost anywhere else.

This type of work requires some means of conveying the audio signal to the main transmitter, and two such systems have been devised. The first employs a program amplifier and telephone lines quite similar to those used between the master control-room and the transmitter, while the other utilizes a low-power short-wave radiotelephone transmitter, operated in conjunction with a communications receiver located either in the master control-room or at the regular main transmitting station.

The former method is now used almost exclusively, while the latter never really passed the experimental stage and is now considered practically obsolete, although it may be used in a few isolated cases of news reporting where wire lines are absolutely unobtainable.

THE PORTABLE AMPLIFIER

The remote amplifier must offer utmost portability plus strict conformity to the most exacting performance requirements. All of the high-quality design features of the regular studio installations must likewise be incorporated in this equipment. Nevertheless, it is often designed and constructed by the station's engineering staff to its own highly individual specifications and requirements.

The single unit may consist of the amplifier and its associated power supply, volume controls, volume indicator, and other essentials. Low-drain tubes and a battery power supply are very often used to assure

greatest flexibility and freedom from hum. If a rectifier power supply is used in conjunction with the public A.C. mains, it cannot be constructed as a part of the amplifier unit, but must be placed at least several feet away. Furthermore, the power transformer must be turned to the point of minimum coupling with respect to the audio transformers.

The amplifier shown in Fig. 1 is designed to operate with either type of supply. It is an excellent piece of equipment, although somewhat more elaborate than is often used for this purpose. In fact, it has been used as a permanent studio installation in some small stations.

The input circuit (R1, R2, R3, R4) can accommodate up to four channels simultaneously, through the parallel mixer. It is designed to work with 30-ohm dynamic microphones or other sources of equal impedance and similar output. Any other source impedance requires a matching transformer into the mixer.

A low-level mixer is used, and the attenuators are of the single-ladder type, which is a somewhat simplified variety of the balanced ladder. Each volume control has an OFF position and a total attenuation range of 45 db., which is not evenly spaced but gradually increases toward cutoff. The output of the mixer is amplified through a single stage and then fed to the master gain control (R5), which is of the high-impedance voltage-divider type, and has a similar 45-db. attenuation characteristic.

Resistance coupling is used between stages, and degenerative feedback provides improved frequency characteristics, less wave-form distortion and phase shift, increased stability, and a lower noise level. Thus under normal operating conditions the frequency response is flat within ± 1 db.

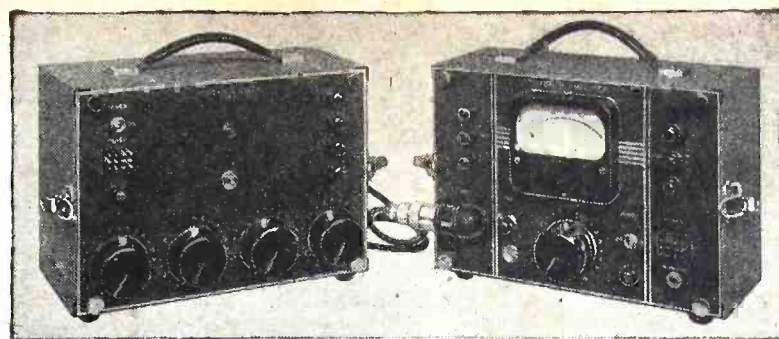

The RCA OP-7 portable mixer and preamplifier and OP-6 amplifier.

between 30 and 10,000 c.p.s., the harmonic distortion is less than 1%, and the noise level is 60 db. below the program level measured at the output.

SWITCHING THE METER

The meter arrangement incorporated in this unit is quite unique and very useful. The meter (M) is ordinarily used as a volume indicator with one scale calibrated in volume units and another independent scale calibrated in units of 0 to 100, in which the 100 reference point is approximately two-thirds up-scale. Deflection to this 100 point can be made to correspond to output levels of +4, +6, +8, +10, +12, or +14 VU by means of the range switch (S1). Usually a level of +8 to +10 VU is fed to the program line. Any value in excess of +12 VU will overload the telephone repeaters, with consequent distortion. The meter may be entirely removed from the circuit through the OFF position, and it has the additional desirable functions of indicating the supply-voltage values through the PLATE and FIL positions. When used in this manner, the 100 reference point represents the minimum permissible operating voltages. Measurements may be made at any time, even when the program is on the air.

The output circuit embodies two line-isolation networks, contrived to operate into an impedance of either 150 or 600 ohms, the
(Continued on page 180)

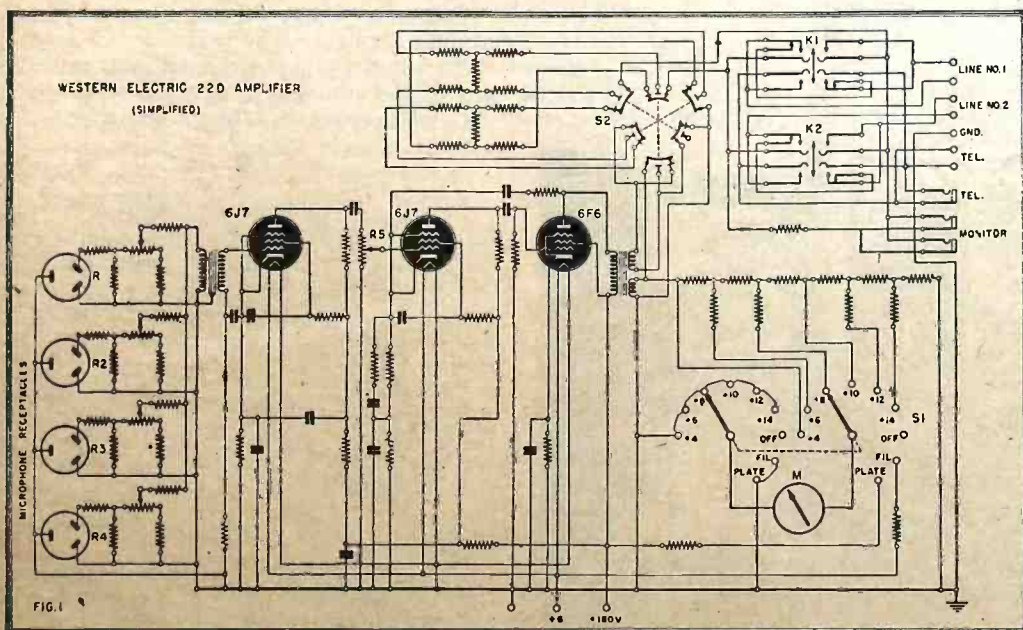

Fig. 1—A diagrammatic digest of the well-known Western Electric 22-D remote amplifier.



Photo courtesy RCA
Announcer carrying OP-6 remote amplifier.

"Kitchen Sink" Trainer

By S. R. WINTERS

THE radio installation on a bombing plane is a complicated affair — a bewildering maze of wires, both hidden and trailing, interphone sets; transmitters and receivers, radio compasses and frequency meters. The radio operator who knows individual receiving sets from baseboard to the finished panel still must learn the art of using transmitters and receivers as they are interconnected on bombing machines. To bridge this missing gap of training, a special radio trainer has been devised by Captain Farno L. Green, communications officer of a B-26 squadron, at a North Africa air base.

What the "Link" trainer is to development of embryo aviators into full-fledged fliers this radio trainer is in the development of wireless operators, on the ground and under make-believe conditions. Bombers, necessarily, have to be employed in transporting lethal loads of explosives over enemy territory—and not as machines for training radio operators. So, in Hollywood fashion, Captain Green simulated actual conditions by designing a model cockpit and radio operator's compartment, then installed and arranged the radio apparatus just as one would find it on a B-26 bomber. The trainer was fashioned from discarded material, except for the transmitters and receivers, and the outfit was completed in less than thirty days. The echelon wiring was done by Sergeants Harvey S. Huffer, Jesse Stewart, John Selign and Thomas T. Tucker.

Full use was made of scrap material in constructing the table. Visitors are always mystified by the piece of apparatus that "looks like a sink." Answer is, that it is a sink! A table was needed and the sink was available and useful for the support the table needed, so was pressed into service. Similar ingenuity was used in assembling the other parts of the trainer.

Lieutenant William B. Monroe, Jr., of

the Mediterranean theatre of air operations, in an official report to *Air Force*, the official service journal of the U. S. Army Air Forces, relates how this radio trainer has halved the required training time and otherwise facilitated the practice of wireless operators. The preliminary step of explaining the procedure is executed with the identical equipment which confronts the student in a bomber. Following each explanation, the pupil pursues actual practice methods. For example, the trainer is provided with an interphone jackbox, thus allowing an instructor to eavesdrop in on two-way conversations between a student and the mock-control tower. Demonstrations may be observed by eight pupils simultaneously; and the wiring remains exposed or accessible for tracing by operators and maintenance crews.

In actual use of this trainer, it was discovered that trained but inexperienced radio operators frequently were confused as to the functioning of the liaison set's trailing wire. The latter not being feasible for use in a cockpit on the ground, a dummy antenna was installed, so that the controls, necessarily, were set the same as for an honest-to-goodness trailing wire, in order to effect contact with the base ground radio station.

This "Link" radio trainer affords practice for operators in hooking up the command radio sets as a substitute for interphone, should the latter be forced out of temporary commission. Furthermore, radio operators are taught cockpit procedure so that they may offer assistance to pilot and co-pilot, should emergency dictate such help. Also, this trainer has been employed in imparting more experience to pilots and co-pilots and, therefore, additional confidence in the equipment. And, still further ex-

panding the service of this special trainer, it has been employed to train navigators in the use of a radio compass, using small transmitters and frequency meters for taking bearings and plotting fixes.

Captain Green, we are told, stresses the emergency procedure and he is of the opinion that, inasmuch as an airplane normally is not in distress and some radio procedure is readily forgotten, each member of the bomber crew should submit himself to this trainer at least once a month, preparing for any possible disaster. He believes that even an experienced radio operator may be forgetful of the function of this liaison set as a quick set-up for voice communication in the event of an emergency. Refresher sessions in such procedure, by virtue of this trainer, are a wholesome reminder of the existing method.

While the Green radio trainer is not portable in the sense of a "walkie-talkie" radio outfit on the back of a Signal Corps man, it can be taken apart into three sections and transported in a two and one-half-ton truck.

DIVORCE VIA RADAR

Predictions of the use of radar in peaceful pursuits may fall far short of the actuality, a recent Chicago divorce trial reveals. The prophets apparently have no idea of how far into American home life the present great war device may reach.

Mrs. Theresa Chadwick, 24, a radar expert in a war plant, appeared in court with a plea for divorce from her husband, Desmond, alleging that he deserted her a year after marriage.

"Can you tell me the reason for the separation?" asked Judge Sbarbaro, who tried the case.

"Well, judge," Mrs. Chadwick answered, "I am a radar expert. He often told me he was afraid I would trace his movements while he was drunk."

Judge Sbarbaro looked worried—thinking possibly of some very complicated cases when peace comes. He also was curious.

"Could that be done?" he asked wonderingly.

"Yes, it could," she answered.

Her husband spoke up.

"She was always fixing electrical things around the house," he said.

She got the divorce without revealing any of the amazing powers of radar—probably for reasons of national security.

Brain-wave of Raymond Scott, CBS band leader, concerns the electroencephalograph, instrument for recording brain activities. Much impressed by the wiggly line drawn out on the tape from that instrument, he has a proposition for electronic-music specialists.

"The basis of every thought is electricity," says Scott. "The more I think about those wiggles, the more I think there is a way of interpreting them. You should not only be able to record them on paper, but will also be able to do it on a phonograph record."

Once his proposed device is perfected, Scott plans simply to sit down and think out a symphony, then be able to play it back from the record immediately it is "thought out."

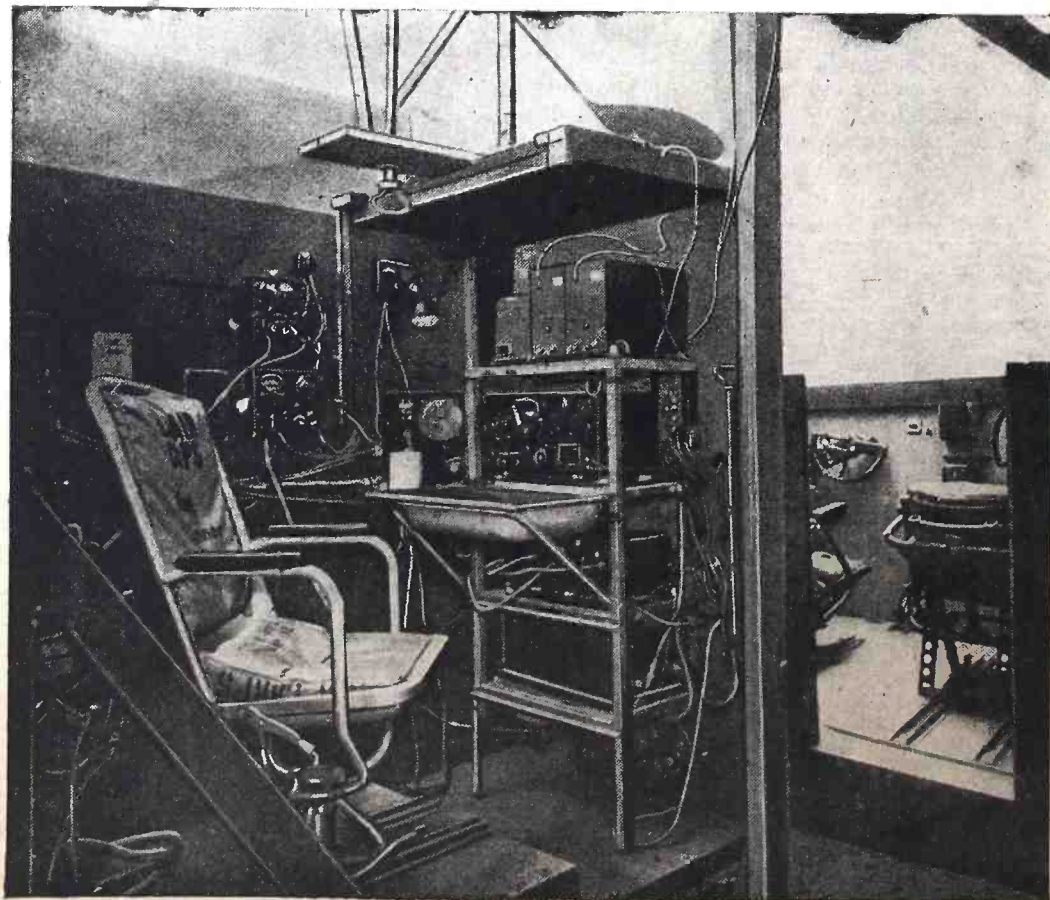

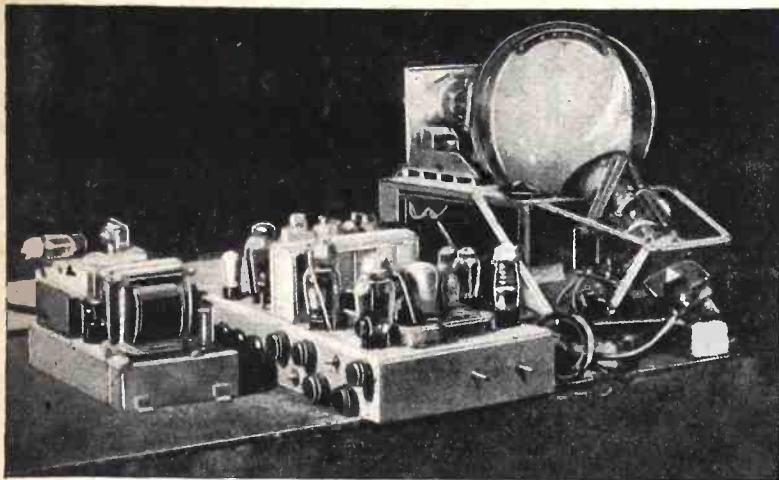

A new experimental color television receiver with Telechrome tube.



Mr. J. L. Baird with his recently invented color-television tube.

“Telechrome”

A New and Revolutionary System of Color Television

NUMEROUS more or less successful attempts at color television have been made, and we have had a few reasonably good color broadcasts. The usual method has been to mount a revolving “color wheel” which interposes filters of red, green and blue successively between the object to be televised and the camera. An identical wheel is synchronized with it at the receiver end.

This system has several disadvantages. Synchronization of any two mechanical devices is always a problem. Neither is it always easy to avoid distracting noise in the revolving system of color filters. Possibly their greatest drawback is absorption of light. There are two of them between the scene and the image, and the loss of light demands much greater illumination at the transmitting end. The filter at the receiving end results in dimmer images.

A new and revolutionary method of purely electronic color television has just been announced by J. L. Baird, one of the earliest and most successful experimenters in the field. His method, known as the “Telechrome” television system, is entirely electronic, the colored image appearing directly upon the fluorescent screen. Two cathode-ray beams are required for a two-color system and three for a three-color system. These cathode-ray beams are modulated by the incoming signals corresponding to the primary color picture and impinge upon superimposed screens coated with fluorescent powders of the appropriate colors. For example, in a two-color system the two cathode-ray beams scan the opposite sides of a thin plate of transparent mica, one side of which has been coated with orange-red fluorescent powder and the other with blue-green fluorescent powder. See Fig. 1. Thus the screen has formed upon its front face an image containing the orange-red color components and on its back face an image containing the blue-green components, these images being superimposed and thus giving a picture in natural color.

Where three colors are to be used the back screen is ridged and a third cathode-ray beam added; the front face of the screen then gives the red component, one side of the back ridges gives the green components, and the other side of the ridges the blue component. See Fig. 2.

A two-sided tube has been developed to receive a picture from a 600-line triple-interlaced moving spot transmitter using a cathode-ray tube in combination with a revolving disk with orange-red and blue-green filters. The receiving cathode-ray tube is shown in the diagram (Fig. 2) and in the photograph. The screen is a 10-inch diameter disk of thin mica coated on one side with blue-green and on the other with orange-red fluorescent powder. The color may alternatively be provided for the back screen by using a white powder and coloring the mica itself.

The tube shown in Fig. 1 may be viewed from both back and front, but if used in this way one set of viewers sees a mirror image. Also, colored mica must not be used, and a filter has to be inserted between the back viewers and the tube to keep the color values correct and compensate for the light lost in the mica and fluorescent powder when the direction of viewing is reversed.

The tube shown in the photograph of the apparatus can only be viewed from the front, but having one cathode-ray beam perpendicular to the screen simplifies the set-up of the apparatus. The tubes give a very bright picture due to the absence of color filters and the fact that special powders are used giving only the desired colors, which are seen *additively*, a great advantage over the subtractive “color-wheel” method.

The tubes give excellent stereoscopic television images when used with a stereoscopic transmitter, the blue-green and orange-red images forming a stereoscopic pair and being viewed through colored glasses.

In a new form of scanning now being developed, successive lines are of different colors and the number of lines is made a non-multiple of the number of colors, so that every line of the complete color picture has successively shown each of the primary colors.

The object of this is to reduce color flicker. Where frame-by-frame color alternation is used flicker becomes prominent in any large area of a single color. For example, if the picture is showing a large blue area, this blue appears in the blue frame only. While the red and green frames are appearing, it is not shown, so that the fre-

quency of the repetition is reduced and flicker accentuated. With line-by-line color alternation, each color appears in every frame.

This form of scanning does not lend itself to the revolving filter disk system.

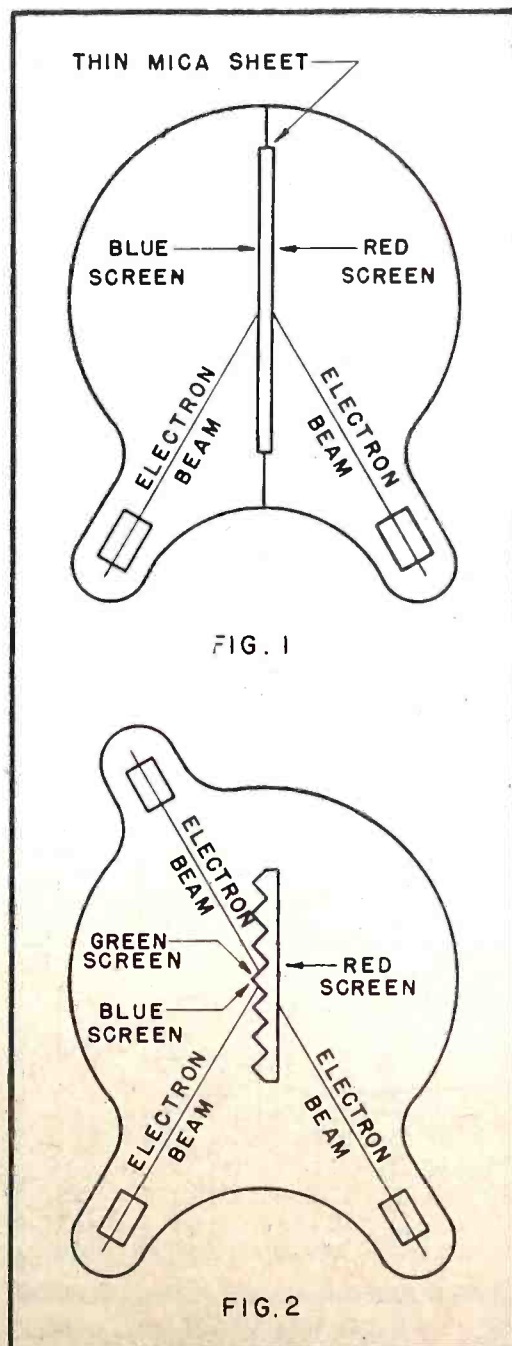

Fig. 1—The two-color tube. Fig. 2—The same principle adapted for three-color television.

Matching Loudspeakers

How to Attach Unlike Speakers to One Output Transformer

By FRED SHUNAMAN

THE technique of speaker matching is well understood by every radioman—up to a certain point. When two speakers of unequal impedance are to be attached to the same amplifier, this understanding is not so general. And if the speakers are of unequal wattage rating as well as voice-coil impedances—each one to receive its correct proportion of the total power—few radio servicemen indeed can toss off an answer to the problem. More than one compromise installation is the result of their inability to do so.

As a simple example: We need to connect a pair of 5-watt speakers with 16-ohm voice coils and one 20-watt speaker

er with an 8-ohm voice coil to a 30-watt amplifier. How are we going to hook up the speakers so that the power will be properly distributed? Remember that the speakers have to be connected across the secondary of a universal output transformer, and the speaker load must be properly matched to that required by the tubes.

The problem is not too difficult. One of the reasons so many radiomen are stumped by it is that they have learned too much about matching. They cannot imagine attaching an 8-ohm voice coil to anything but an 8-ohm tap. If it becomes necessary to hook a monitoring speaker across the 500-ohm line, they do it with dark forebodings as to what might happen at the other end. It is necessary to forget all that. If we are going to connect several speakers to the same winding, obviously we cannot proceed as if we had only one, and that means we can't "match" tap and speaker ohm for ohm.

TRANSFORMER CALCULATIONS

The chief reason for an output transformer is to match the impedance of the output tubes' plate circuit (usually between 2,000 and 10,000 ohms) to that of the speakers' voice coils (commonly between 2 and 16 ohms). If the voice-coil impedance is 6 ohms and that required by the output plate circuit—for best results—is 6,000 ohms, the impedance ratio is 1,000 to 1. The voltage ratio is the square root of the impedance ratio, or in mathematical terms:

$$\sqrt{Z_1/Z_2} = E_1/E_2$$

Our specimen transformer then has a voltage step-down of $\sqrt{1,000}$, or about 31.5. It is likely to have about 2,000 to 3,000 turns of wire on its primary and from 60 to 90 turns on its secondary.

The impedances of a universal output transformer are usually marked, but the turns or voltage ratios are not. Our only interest in these voltage ratios is that they help us to understand some of the electrical actions of the transformer, and thereby to figure out which of the secondary terminals we have to attach our speakers to. (The principles underlying impedance ratios, reflected loads and other features of transformer action were covered in the article "Output Transformers" which appeared in the September, 1943, issue of *Radio-Craft*. If the reader is not clear on these points, the article should be re-read before going farther with this one.)

To get the underlying principles straight let us try the simplest possible hookup (Fig. 1). The whole 30 watts is being fed into one 8-ohm speaker. Voltage across the 8-ohm voice-coil winding is 15.5 roughly ($W = \frac{E^2}{R}$, or $30 = \frac{E^2}{8}$).

Amperage is 1.94. The impedance ratio, Z_p/Z_s is 6,000/8 and the voltage ratio is the square root of that, about 27.4. The primary voltage is $15.5 \times 27.4 = 425$ approximately. This can be checked by calculating direct from the

Now we can try a hookup like that of Fig. 2, which has two secondaries. We connect the two 16-ohm speakers in parallel, making an 8-ohm unit to place across one secondary. The 20-watt speaker, also an 8-ohm unit, goes across the other. What should be the impedance of the primaries?

First, 10 watts must be fed to the two-speaker unit. Using our formula, $10 = \frac{E^2}{8}$

or $80 = E^2$, the voltage across the voice coil works out to slightly less than 9. To get the voltage ratio, we divide 425 by 9, which is 47.2. Since $Z_p/Z_s = (E_p/E_s)^2$, we square 47.2, giving us 2,228. The impedance is $6,000/2,228$, or roughly 2.68, which should be the rated impedance of a winding to supply the two small speakers.

The single speaker is to draw 20 watts. The same calculation makes the voltage

$$12.65 \text{ about. } (20 = \frac{E^2}{8} \text{ or } 160 = E^2)$$

Dividing that into 425, the turns (voltage) ratio is near 33.6. Squaring this, we get 1128. The impedance of the secondary coil is $6,000/1128$, or roughly 5.32 ohms.

(All the foregoing figures are obtained from the slide-rule, and are approximations, but are more than accurate enough for this work.)

Since the secondary impedances are effectively in parallel, two separate windings are unnecessary. It is easier to hook each speaker to the proper impedance tap on a universal speaker, as in Fig. 3. This is what is done in actual practice.

THE REFLECTED IMPEDANCE

Now, are these impedances correct? On the surface, it would not seem so. One 8-ohm winding is attached to a tap whose impedance is slightly less than 3 ohms—the other to one of a little over 5 ohms impedance. Let us see if anything like 6,000 ohms is reflected back into the primary. If so, the speakers are matched to the output tubes.

The impedance reflected into any primary winding is due to the resistance of the secondary load and the transformer ratio. An 8-ohm load across an 8-ohm tap reflects the rated impedance (6,000 ohms in the case of our transformer) back into the primary. Placing the same load across a 4-ohm tap would reflect 12,000 ohms or $4/2$ the normal impedance.

One of our windings will therefore reflect $8/2.68 \times 6,000 = 17,900$ ohms and the other $8/5.32 \times 6,000 = 9,060$ ohms. Adding the two parallel impedances, we get $1/17,900 + 1/9,060 = 1/6,000$. The impedance reflected into the primary is 6,000 ohms. The speakers are effectively matched to the amplifier.

In many cases the required impedance taps are not found on the output transformer. Connect to the nearest tap, checking the effect on power distribution and so averaging the mismatch of individual taps that the total reflected impedance will be as nearly correct as possible. If it is

(Continued on page 184)

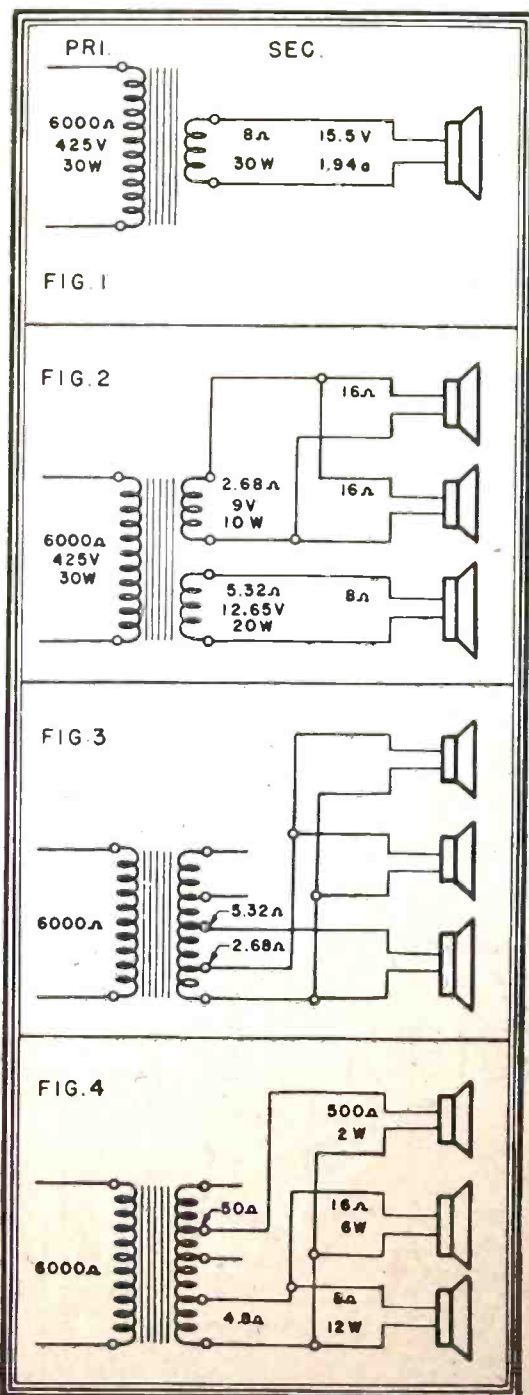

Fig. 1—Simplest speaker matching problem.
Fig. 2—How three speakers could be matched.
Fig. 3—All three on one output transformer.
Fig. 4—Matching widely different speakers.

The Square Wave Generator

How This Simple But Little Understood Circuit Works

By HARRY BERGQUIST

PERHAPS the simplest of the wave shaping circuits are those used for the generation of the square wave. For these, we may use a sine wave input (Fig. 1-a), and by removing a portion of the top and the bottom, we have left a square wave.

It may be seen, by the study of Fig. 1-b that the more of the peak is removed, the better the resultant wave form. The whole idea is to have a straight side, square corners and a flat top. Each time the wave is "clipped" in a circuit of this type, it must also be amplified. Otherwise a point would soon be reached where further "clipping" would result in a straight line. That is why several stages of amplification are generally used.

Fig. 2 is an illustration of a perfect square wave. That is, one in which T_1 will equal T_2 . The time consumed through the top of the wave should be exactly the same as the time consumed through the bottom of the wave. The time from "a" to "b" would also have to be zero, since "ab" represents the time involved to reach the amplitude of the wave. This must be true, because the less time required to reach "b," the more vertical will be "ab." Since theoretically, there can be no such thing as a pure square wave, we must try to use an oscillator which will generate as pure a sine wave as possible, and then try to clip this wave as low as possible. (The lower the wave is clipped, the more vertical will be "ab".)

SIMPLE SQUARE-WAVE CIRCUIT

Perhaps the simplest method to generate a square wave is to overdrive an amplifier, biased for class "A" operation. To show such action, the dynamic plate characteristic curve of the pentode is used (Fig. 3).

We see that with a filament voltage, which is fixed and constant, plate current will increase as the voltage applied to the grid is increased. When the grid voltage has risen to point "a," plate current has almost reached the point of saturation. Any increase in grid voltage now will cause little change in plate current.

Fig. 4 shows the actual bias of the tube. Line E_g is the grid voltage line. This is the actual operating point of the tube. The amplifier, when overdriven, will cause grid current to flow through the grid leak resistor. When this happens, we have distortion from the opposing voltage. The points shown in Fig. 4 represent time. In other words, "1" and "2" represent the time involved to reach saturation; "2" to "3", the time of plate current non-linearity; and "3" to "4" the time involved to reach zero. On the negative half of the cycle, "4" to "5" shows the time to reach cut-off; "5" to "6", the time the tube is cut-off, and "6" to "7", the time involved to reach zero. We can now develop the plate wave form graphically, as in Fig. 4, bringing the lines downward to develop the squared wave form.

When the wave is shaped in the grid input, where we have a condenser-resistor combination, and a sine wave is applied, the true grid wave form is distorted or partially squared.

To further explain how this wave form

is developed, we will use a pentode in an amplifier circuit. This tube should now be biased for class "A" operation.

We will first use the positive half of the cycle, and sufficient input to drive the tube past saturation point. As the signal voltage causes the grid to go positive, electrons flow through the grid leak resistor. This causes a voltage opposite to the positive polarity of the applied signal, thus subtracting from the signal and causing a flattening of the grid peak.

On the negative half of the cycle, the voltage applied to the grid is added to the normal bias of the tube. This negative voltage causes the flow of electrons to the plate to be cut off almost instantaneously, such cut-off being possible for a short time by the storage action of the cathode bypass condenser. Since no more electrons can now reach the plate, current ceases, there will then be no further change in plate voltage until the negative grid bias decreases to the cut-off point.

During the positive half of the cycle plate current will be maximum and the voltage low. During the negative half of the cycle, current will be minimum and voltage high. Because of the plate load resistance, the plate voltage will decrease in direct proportion to any increase of plate current.

WAVE FORM IMPROVEMENT

If the output voltage of this square wave generator is now measured between plate and ground with an oscilloscope, it will be found that the wave form will be approximately square. That is, one which has sharp transitions from maximum to minimum when the signal voltage changes from negative to positive, and fairly sharp transitions from minimum to maximum when the voltage changes from positive to negative.

The wave form will not be very satisfactory with this circuit. To overcome this, a grid clipping resistor is sometimes used in the input, as in Fig. 5. When sufficient positive voltage is applied to the grid con-

denser, there will be a current flow through the grid leak resistor, and there will also be a small voltage drop across the resistor, but this will be negligible. This is due to the discharge of the condenser through R. Only a small portion of the electrons will be able to strike the grid. Those that do, create a strong cancelling voltage, like that previously described, but now more important since it is increased by drop in the limiting resistor.

Fig. 6-a represents the circuit in a simplified form. The limiting resistor is shown as R_{g1} and the dynamic grid resistance of the tube as r_g . From Fig. 6-b, we see that during the time grid current flows, r_g will be low. During the time grid current does not flow r_g will be infinite. Further study of the illustration also shows that R_{g1} and r_g form a voltage divider circuit, which in turn shunts a resistance of larger value, or R_{g2} . (Fig. 6-b.)

THE ACTION ANALYZED

Now to follow the signal voltage through the circuit, a sine wave voltage is applied through the grid coupling condenser. During part of the positive half of the cycle, r_g is reduced to a small value, thus giving voltage divider action. Most of the signal voltage will be developed across R_{g1} and a very small amount across r_g . Therefore, the signal voltage, between the grid and cathode will be small. During the negative half of the cycle, R_{g1} will be of infinite value. Therefore most of the signal will appear on the grid.

As a further representation, we may use a ratio of unit values. The rise of the positive peak on the grid, while grid current flows, may be shown as 1, while the applied voltage would be 10 times as high. This in turn would cause a clipping of the peak, as shown in Fig. 6-c.

If the voltage is measured between grid and ground with an oscilloscope, the wave form will be found to be essentially squared

(Continued on page 185)

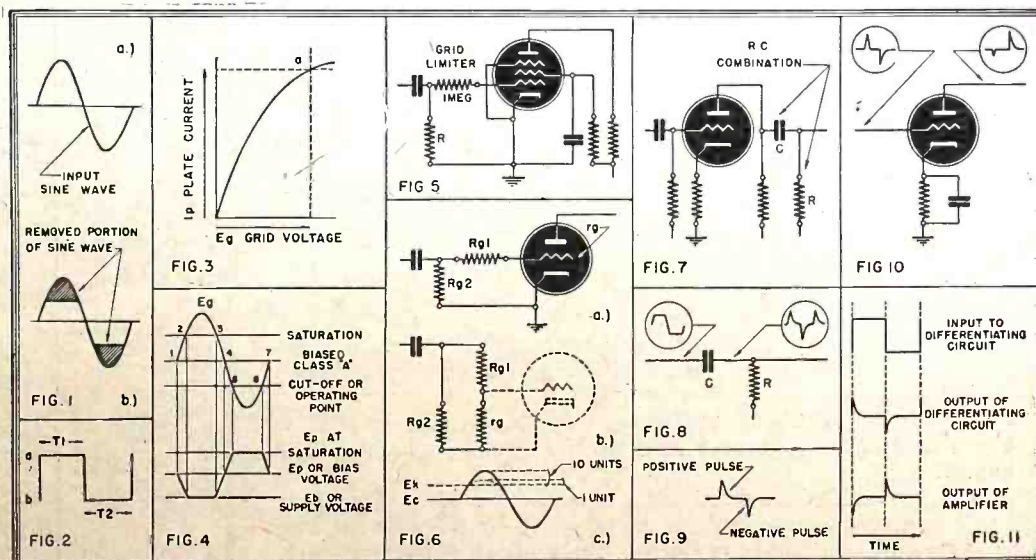

Fig. 1—Before and after clipping. Fig. 2—Ideal square wave. Fig. 3—Dynamic E_g-I_p curve. Fig. 4—Making a square wave. Fig. 5—Limiting resistor. Fig. 6—How it works. Fig. 7—Differentiator circuit. Fig. 8—Pulsing circuit. Fig. 9—Positive and negative pulses. Fig. 10—Positive pulse amplifier (negative clipped). Fig. 11—Pulse wave forms (not to scale).

Automatic Changers

PART II—RECORD SELECTING MECHANISMS

By JOHN NEEDRE

A COMMON type of repeating mechanism is shown in Fig. 1. The cam wheel is allowed to rotate continuously but no levers are in contact with it. The trigger serves to throw another arm into a groove on the cam wheel. The arm will follow this groove like a track from one end to the other until it is ejected at the end of its course.

The trigger of a repeat mechanism may be activated by a solenoid, a mechanical system, or by a manual impulse from a push button. In practice, the push button (labelled "Reject Button") is employed in conjunction with one or the other of the automatic repeating systems.

In order to play records one at a time when they are stacked upon each other, selector blades are employed. These blades "slice" one record at a time from the stack, as one would separate a piece of bread from a sliced loaf by sliding a knife blade between the slices.

One device, less frequently used, picks the top record from a stack and drops it into a container at the side of the turntable.

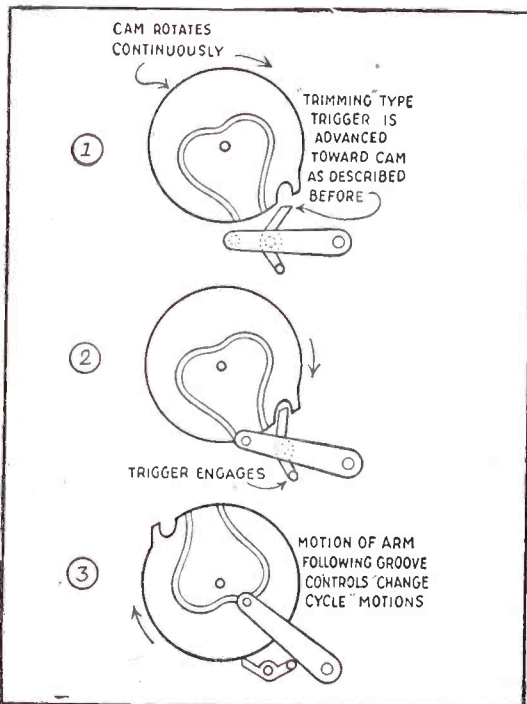

Fig. 1—A repeater operating on the same principles as those described last month.

These employ the system in which the stack of records to be played is supported directly above the turntable so each record may be separated from the stack bottom and allowed to fall in place on the turntable. (See Fig. 3.) To carry out this operation, the blades supporting the records must turn or slide from under the lower record and allow it to fall. At the same time a "selector blade" must slide under the second record from the bottom and prevent it, and the other records stacked above it, from falling with the one to be played.

ECCENTRIC DEVICES

A record releasing device, used a great deal because it is simpler and therefore less expensive, is the eccentric shaft method, illustrated in Fig. 4.

In this case the records are supported on one side by a stationary post and at the center hole by the spindle, which is also stationary.

Since the spindle does not rotate, a rim drive is used so that turntable motion does not have to be provided by the spindle. The upper portion of the shaft is out of line with the lower portion, thereby providing a seat for the record at "b" on the diagram, since the hole is not large enough to let the record slip down any further. The operation may be seen from the diagram.

A dotted line in the lower portion of the spindle indicates a shaft coming up through the center of the hollow spindle from

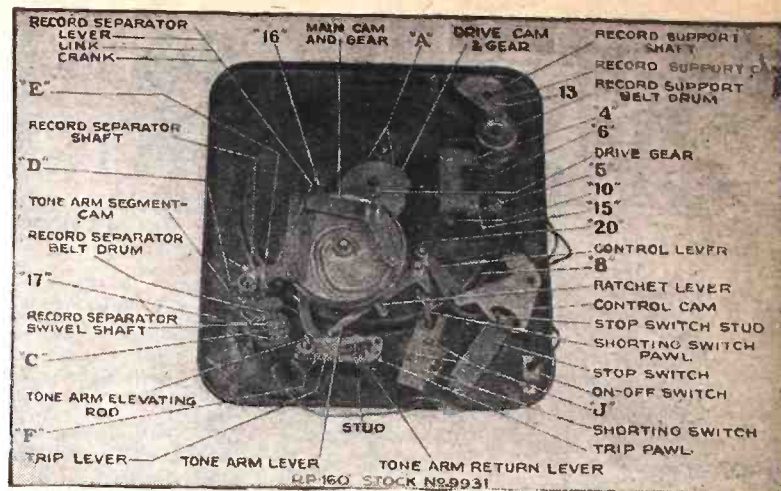

Courtesy Radio Corporation of America

Under-chassis view, in detail, of a modern automatic record changer of the type found in many home radio-phonograph combinations.

the cam wheel's axle. During the "cycle" this rotates once causing the eccentric section, "A," of the spindle (which is the same thickness as the record), to pull the lower record off the stationary support, at the same time lining up with the lower portion of the spindle so that the record may slide down to the turntable unimpeded.

This arrangement sometimes causes trouble when old records with worn center holes are used, as do other types when playing warped or bent records.

Another setup using an eccentric shaft is diagrammed in Fig. 5. In this case the spindle rotates continuously and supplies motion to the turntable.

This type has an eccentric cut in the shaft. During the playing of one record, the other records are lined up with the shaft. As the change cycle begins, a lever, shown in dotted lines inside one of the supports, pushes the lower record into the eccentric cut, which in its rotation pulls the record out till it is aligned with the lower portion of the shaft and is clear of its support at one side. On the return half of the revolution, the record is pulled clear of the other support, and drops into playing position.

NEEDLE LANDING PLACE

When the pickup arm approaches the turntable it must come to a stop above the outer edge of the record so that it may then be lowered mechanically by the cam to touch the record at a point approximately three-eighths of an inch from the edge. This is the place where the recording grooves start and is known

(Continued on page 175)

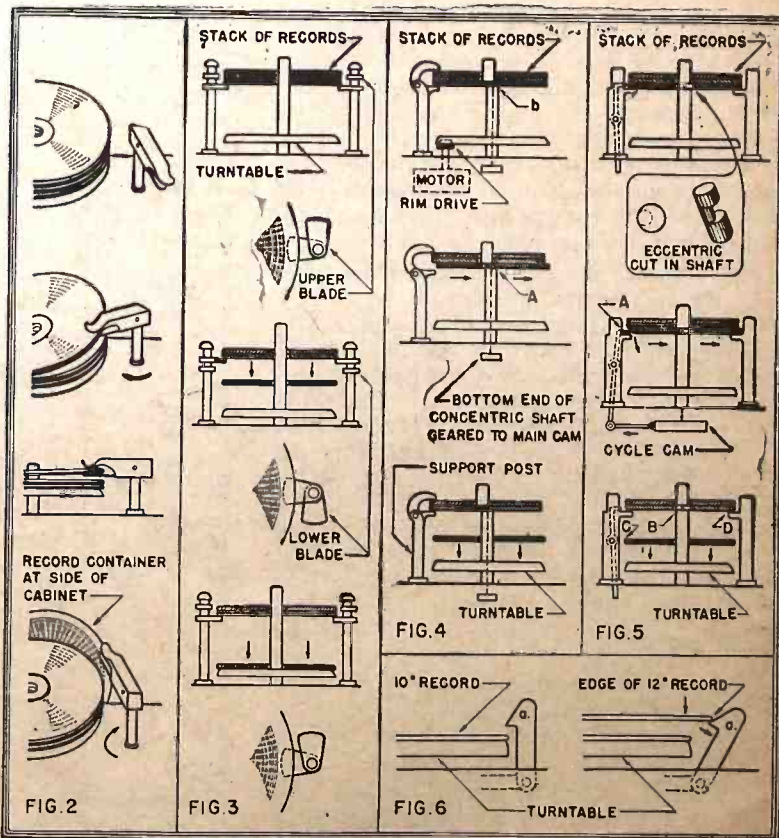

Fig. 2—Old-type record selector. Fig. 3—A common modern method. Fig. 4—Eccentric-shaft mechanism. Fig. 5—The details of another eccentric-shaft method. Fig. 6—A 10- and 12-inch changover lever.

Industrial Electronics

PART X — Here and There in Industrial Electronics

By RAYMOND F. YATES

THE art of electronics has now progressed to a point where a great and highly diversified miscellany of uses are present. Rare is the industry or craft that has not been touched by it. The application shown in Fig. 1 is an example of the fact that one never quite

silk threads are substituted for F. When these are run through the equipment they cause variations in light according to their diameter and translucence. This unbalances the bridge and causes a voltage drop

In this instance, an "electrical" model was made for each house under study and these were connected to an electrical power source which took the place of the furnace. Four thyratrons and a pentode comprised the electrical model of each house under investigation and a 24-hour heating period was thus electrically scaled down to 1/60 sec. Such an electrical system permits a long period of research to be squeezed into a few months. The research work is being conducted by M.I.T. and Sperry Gyroscope Corporation.

It has been assumed that each part of the house, the walls, roof, windows, etc., has its electrical counterpart that may be expressed in terms of networks as in Figure 4. These are what may be called resistance-capacitance networks of a house. Potential E represents the outside temperature and J represents the furnace itself.

The flow of heat through conductors which have thermal resistance and capacitance and the flow of electricity through electrical conductors which possess resistance and capacitance, as they must, are related intimately and respond to analogous laws and have the same differential equation.

Fig. 5 illustrates the control circuit employed when studying the equivalent circuit of a house. This arrangement is bound to become a most important tool in the investigation of thermal insulation.

Still another very ingenious application of electronics to industrial problems was made at the Ranger Aircraft engine plant for the testing of in-line crankshafts. An audio oscillator of great power (output up to 1 kw) was used. The output of this was fed into an electromagnetic device which changes power into torsional motion. Such a crankshaft, designed to transmit over 500 h.p., may be completely broken when less than one horsepower of improperly applied torsional power is used against it.

When such an in-line crankshaft is to
(Continued on page 172)

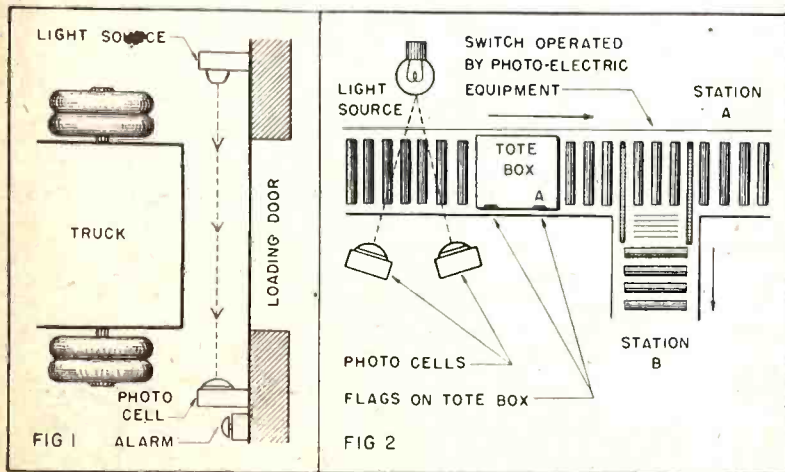

Fig. 1—Photoelectric assistance for the truck driver. The bell prevents crashing.

Fig. 2—Switch system on a conveyor. If the flags stop both light beams simultaneously, the box is shunted to a sidetrack.

knows where the electron tube will show up next. Here we find it on a truck loading platform. The manufacturer in this instance was constantly suffering damage not only to his building but to the tail ends of his trucks. The photoelectric limit alarm saved him several thousands of dollars in his repair bill every year.

Control of tote boxes in factory conveyor systems offers another example of the versatility of electronic devices. Some of the more elaborate conveyor systems have junction points where the steel tote boxes take a switch. Attempts to devise automatic mechanism before electronics came along were not successful. Placing a man at the junction was far too costly. The arrangement illustrated in Fig. 2 was finally designed and is now providing yeoman service.

Electronics is used extensively in the inspection of manufactured electrical equipment. Counting the number of turns in a coil is an example. The device has an accuracy of plus or minus one turn of wire in a coil of 500 turns.

The coil to be examined is placed on an iron core, the same as an adjacent tapped standard coil. It is electrically opposed to the standard coil. Decade selector switches are then operated for zero galvanometer deflection which indicates that both coils are the same. This is very much on the principle of the old Hughes induction balance.

One of the most ingenious applications ever made in the industrial inspection field is the equipment designed for photometering silk intended for stockings and fine quality silk underwear. The result of a long investigation was the Evanometer, the simplified diagram of which is illustrated in Fig. 3.

The device is comprised of six units. No. 1 is the photoelectric bridge circuit where $R_1 = R_2$. The bridge circuit is balanced by means of the adjustment on the light valve V until precisely the same degree of light reaches the photo-cell 2 as is transmitted through the standard F to the No. 1 photoelectric cells.

In making use of the device, samples of

across R_2 . The effect is to swing the grid of the pre-amplifier, and is then passed in highly amplified form to the linear amplifier No. 3 or No. 4, called the logarithmic amplifier. Output of either amplifier gradually creates a voltage across the condenser plates in No. 5. This is in direct proportion to the output current and is invariably in a positive direction. From this it will be seen that No. 5 integrates output from the No. 3 or 4 and that the voltage is taken off the condenser by the VTVM in No. 6. The output of the latter is recorded on a sensitive watt-second meter.

If the diameter of the silk threads in the samples and the degree of unbalance of the bridge is correlated, the recording meter may be calibrated in diameters, providing the interval time is always the same.

Some very interesting applications of electronic equipment in the study of thermal behavior of houses have been made.

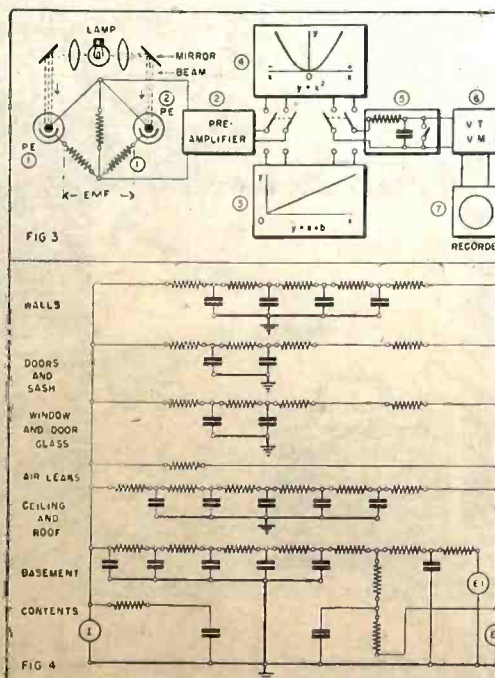

Fig. 3—"Glamour checker" for measuring silk stocking sheerness. Figs. 4 and 5—Thermal network of building and its control system.

Speech Amplifier Design

PART III — Internal Feed-back Problems

By ROBERT F. SCOTT

THE degree to which the falling off at low frequencies in a resistance-coupled amplifier takes place may be seen by the fact that the critical frequency which makes the reactance of the coupling condenser equal to the combined resistance of R_p , R_l and R_g , in parallel, will have only 70.7 percent of the amplitude at intermedi-

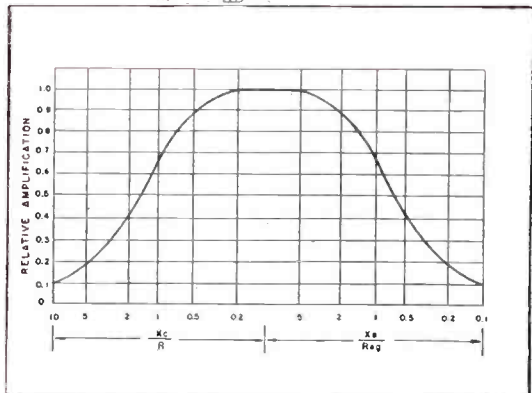

Fig. 1—The universal amplification curve.

ate frequencies. This frequency is known as "the nominal low-frequency cutoff" and is designated as f_1 . It will be noted, from the universal amplification curve (Fig. 1) that signals having frequencies equal to multiples and sub-multiples of f_1 have definite relationships to the intermediate frequency gain. This is because the reactance varies inversely as the frequency. It is therefore conclusive that the voltage drop across the coupling condenser is inversely proportional to the frequency. It may be well to mention that this curve applies to all resistance-coupled amplifiers regardless of the frequencies being passed; thus this curve may be used for computing gain and response curves for either audio or video amplifiers.

It will be noted from the universal curve that there is a point where the high-frequency gain drops to 70.7 percent of the intermediate frequency value. This frequency is called "the nominal high-frequency cutoff." It is that frequency which makes the reactance of the shunting capacitances equal to the resistance formed by the parallel combination of the plate resistance, plate loading resistance and the grid leak resistance. It will be seen from the curve that, as with the low frequencies, the multiple and sub-multiple frequencies of the nominal high-frequency cutoff frequency have the same relationships as in the low-frequency ranges.

If you wish to prepare your own uni-

versal curve for use on specific circuits, the nominal cutoff frequencies may be calculated from the equations below.

$$\text{Low freq. cutoff} = 1/6.2832 \times C_c \times R$$

$$\text{High freq. cutoff} = 1/6.2832 \times C_t \times R_{eq}$$

Throughout most of this discussion we have taken the triode tube for most of our calculations, it should be noted that the same equations may be applied to the pentode tube with the exception of the equation for finding the gain of a pentode stage at intermediate frequencies. The equation which applies in this instance is

$$\text{Gain} = \frac{E_o}{E_s} = G_m \times R_{eq}$$

where R_{eq} = equivalent resistance formed by plate resistance, plate load resistance, and grid resistance in parallel.

Interesting to note is the fact that when a given value of coupling condenser has been selected, the grid resistor for good low frequency response should be as large as practical; while a low value of grid resistor is most desirable for good high frequency response. This apparent contradiction may be overcome by selecting the circuit constants so that the grid resistor is small enough to counteract the shunting effect of the inter-electrode and shunting capacitances while the coupling condenser is

made large enough to pass the lowest frequency without noticeable attenuation.

You have been told that the input capacitances of a tube will depend upon the gain of that tube in a particular circuit. The total shunting input capacitance is equal to

$$C_{input} = C_{gc} + (M + 1) C_{gp}$$

Where

C_{gc} = grid-to-cathode capacitance

C_{gp} = grid-to-plate capacitance

M = voltage gain of the stage

To the input shunting capacitances should be added the output capacitance of the tube preceding the output resistance network, found from the tube manual, and 7 micromicrofarads for stray capacitances.

Another factor which may make its presence felt in the amplifier is insufficient values of cathode by-pass condenser, C_k . It makes its presence felt by causing an undue reduction in the low frequency response. It is this condenser which is used to by-pass the audio voltages present on the cathode around the biasing resistor. If the reactance of C_k is high when compared to the value of R_k , at the lowest frequency, there will be an additional voltage drop across R_k due to the presence of the audio
(Continued on page 170)

ELECTRONIC MEGAPHONE IN USE



Courtesy Newcomb Audio Products Co.

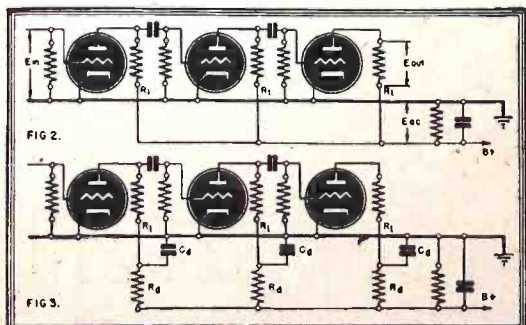
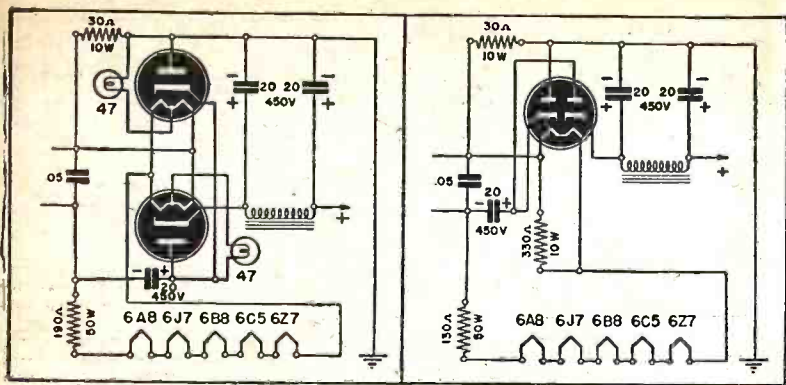

Fig. 2—Internal impedance causes feed-back.

Fig. 3—Isolating filters eliminate coupling.

This portable sound system with self-contained power supply is typical of the units used on scores of invasion beaches. It weighs 39½ lbs. including mike, power supply and speaker, can easily be carried by one man, and has a half-mile range on land. On water, under good conditions, it can be understood over a much greater distance, and has been used at two miles.



Figs. 1 and 2—Common types of voltage doublers. A third standard type is not shown. It is well to use slightly higher voltage ratings than appear necessary in condensers for voltage doubling.

Battery Conversions

Old Radios Can Be Remodeled at a Profit

By W. A. RIEVELEY

WITH large numbers of people moving into the cities from the country, battery sets have become plentiful and A.C. radios rare. These battery sets may easily be converted to A.C. use. I have the following conversion method used successfully at a profit. The 2-volt radios are bought very cheaply and by using a voltage doubler will give better results than the original set. The 1.4-volt sets are even more easily converted. In most cases they may be used on A.C. and D.C. power lines. The latter type of radio allows the ingenious radio man room to play as there are several tubes combining the pentode or output tube with a half-wave rectifier.

The later types of 2-volt radio are perhaps most common and should be dealt with first. A common tube setup in these radios is 1C6 or 7 or 1A6 as converter; 1A4-P or 105GP in the I.F. amp., 1F6 or 1F7 as diode-det.-amplifier, with a 30 or 1H4G driving a 19 or 1J6 in the output. By referring to the tube manual we find tubes that can be used with only minor circuit

changes. Our converter is a 6A8, the I.F. tube a 6K7, for our diode-pentode a 6B8, the driver tube can be a 6C5, and a 6Z7G in the output circuit.

There are two types of voltage-doublers in common use. Of these I prefer the one shown in Fig. 1. By using two 35Z5 tubes in this circuit we get sufficient voltage and current for a good sized radio. The heaters are in parallel to handle the 300 mils required by the other tube filaments, which are in series with the 35Z5's and a resistor across the line. The 35Z5's also provide heater taps so that dial-lights may be easily connected in the circuit. By using a 330-ohm resistor across its heater a 50Z7 may be used as shown in Fig. 2. If one can use 150 mil heater tubes all through the circuit the 330 W. resistor may be dispensed with.

In 1.4-volt sets things are made very easy. You can plug the exact A.C. equivalent tube in without replacing the sockets. 1A7 to 6A8, 1H5 to 6Q7 for example. In the case of the 1N5 to a 6J7 or 6K7 terminals 5 and 8 will have to be connected together. The output tubes 1A5, 1C5, 1Q5,

1T5 or 3Q5 may be replaced by a 25L6 or a tube combining the output tube and a half-wave rectifier. A 70A7 works well here as it also has a tap on the heater for a dial-light.

A little study of the tube manual will reveal many other tube combinations for battery set conversions.

A few remarks about speakers may help here. Most sets have good P.M. speakers which I leave in the radio. These may be replaced with ones having field coils, which may be used as chokes in the power supply. If the P.M. is left in a choke or resistor will have to be used in the power supply filter.

In these change over jobs be sure to check the size of the bias resistor and put bias resistors in where "C" batteries have been removed. Some circuits may need extra by-pass condensers, but only in rare cases.

It will be found that converted radios work very well, and this is a way of clearing those old battery radios out of the shop.

I always draw two V schematic diagrams of the converted radio. One is for the shop file and the other is placed in the radio for those who may have to repair it.

A P.A. SURVEY

TODAY almost every defense plant in the nation has a P.A. or sound system designed to fulfill a dual purpose: stimulate factory production and cut down worker fatigue, and serve as a means whereby the key executives can talk directly to the workers without leaving the front office.

The Lamson Company of Syracuse, N. Y., and The Porter Cable Co., of the same city, have conducted surveys as have the Watertown Air Brake, of Watertown, N. Y., and Eastman Kodak of Rochester, and other industrial plants. Many of the points covered in this series of experiments are well worth examining.

Possibly the most important phase of this series of surveys had to do with the volume level at which the music is offered in the various departments. There exists in every section of a defense plant varying machine noise levels. The music must come through clearly above the noise of the machines or the value is lost. Workers develop acute nervousness straining to catch occasional bursts of melody.

Next in importance is the question of timing. Not more than ten minutes of musical recordings at a time is recommended. The survey shows that one ten-minute musical interlude every three hours is the correct dosage. For example, on the 8 A.M. to 4 P.M. shift, interludes at 10:30 to 10:40 A.M., 1:30 to 1:40, and 3:00 to 3:10. On the 4 P.M. through midnight stint recordings are heard at 5:30 to 5:40 P.M., 8:20 to 8:30, and 11:05 to 11:15. During the most trying shift of all—the graveyard or midnight through 8 A.M. period—records are played at 2:30, 5:30 and 7:45 A.M. It's found that the last few moments of any shift carry with them a definite worker-efficiency let down unless the musical stimulus is present.

Newscasts, according to the survey, are definitely desirable—once on every shift. No attempt is made to hide bad news from the workers or over-emphasize glad tidings. A standard ten-minute digest of the news prepared from newspaper and radio bulletins is best and should be presented at the beginning of every shift. These newscasts are prefaced by this message: "If the news you hear is good—keep your production up so the news will continue to be favorable. If the news is bad—work twice as hard and help turn the tide."—E. A. C.

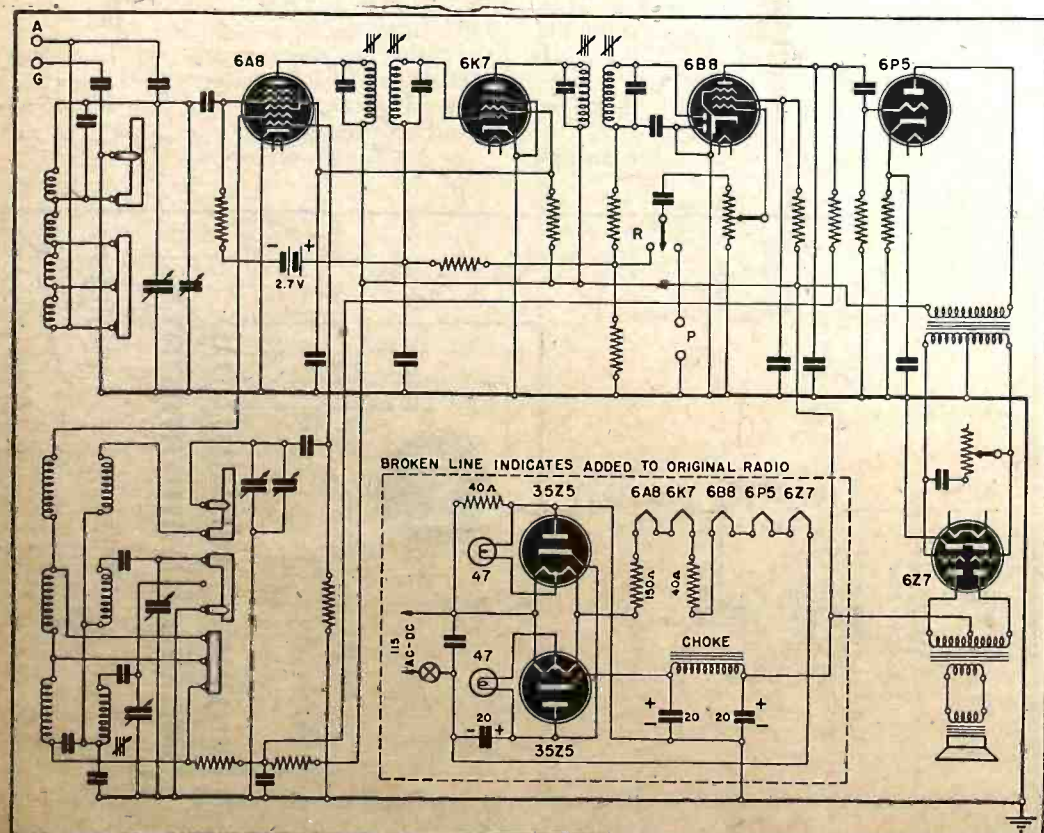

A converted RCA 85BK (85BT). The reader should compare this with the original schematic.

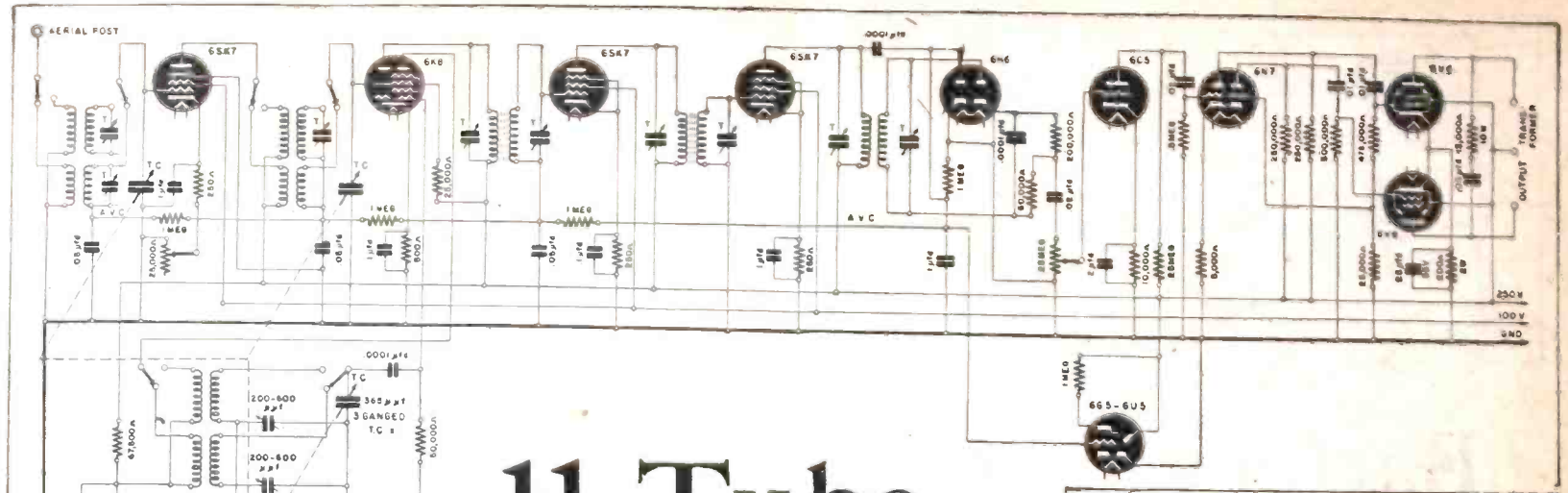

11-Tube Superheterodyne

By EMMETT BRIGHTWELL

AN examination of the layout of this receiver will reveal little that is new, but there are two features that are seldom used in either commercial or custom built receivers. I don't know why, for they add little or nothing to the overall costs, but immeasurably to the quality of the output.

Notice the wiring of the 6H6, the second detector. Do you often see A.V.C. taken off like that? There's a very good reason for doing it this way, which will be gone into thoroughly later.

Now have a look at the power tube hookup. Take note of the filter connecting the plates in shunt with the output transformer. This filter consists of a high wattage wire-wound resistor in series with a .05 Mfd. condenser. This condenser must be good, and the installation must be rigid, in the clear, and the point of joining safe from contacts with other components that might connect to ground.

Now let's begin at the aerial and give the set a detailed examination. The input is entirely orthodox. Notice that the Meissner two-band aerial coil has a common ground so that when the switch is set for one band, the corresponding coils on the other band are grounded. This limits strays and parasitics to a minimum. The trimmers are about 3-15 Mmfd. mica. The A.V.C. being series fed, there is a decoupler consisting of a .1 megohm 1/2 watt resistor and a .05 Mfd. paper tubular condenser as a by-pass in each controlled stage, of which there are three only.

You will notice that the suppressor of the R.F. (6SK7) tube is connected directly to ground. This lessens materially the tendency of a hypersensitive R.F. stage to feedback. We could step up the screen voltage on this stage to 150 volts. (Take it direct from B-plus through a 60M ohm resistor) and use a 6AB7/1853—if we had a 6AB7/1853! The 25,000-ohm sensitivity control is necessary.

The mixer or converter stage is conventional with this exception: The 6K8 you will find, is rearing to oscillate. I have never been able to get an oscillator transformer specially designed for this tube. Most standard-wound transformers are designed to work with the 6A8. This delivers too much current for the triode section of the 6K8. We have a choice of two procedures. We may either remove

windings from the tickler, or we may reduce the voltage.

Removing windings is more complicated than reducing voltage. Through many experiments I have discovered that the 6K8 triode oscillates best with a standard-wound oscillator transformer when there is 83 volts on the triode plate. You get this from a 250-volt source through a 67,500-ohm resistance. That's for dual wave service. The Broadcast band does a mite better with a 60,000-ohm resistor, while the 19-meter band responds best to 75,000 ohms. Therefore I have chosen the compromise value.

The input I.F. transformer is the iron-core type, wound for 456 kilocycles. They tune from 350 to 600 Kc. You simply peak the resonance at the best point, 455 Kc.

The second I.F. is also if iron-core construction, and this is the last A.V.C. controlled stage. Notice that this second I.F. transformer has the lower end of the secondary connected directly to ground. This reduces to a minimum overmodulation caused by the reaction of A.V.C., and if there is a controlled R.F. stage and a controlled mixer stage, no control here is useful.

But I ran fresh out of iron-core trans-

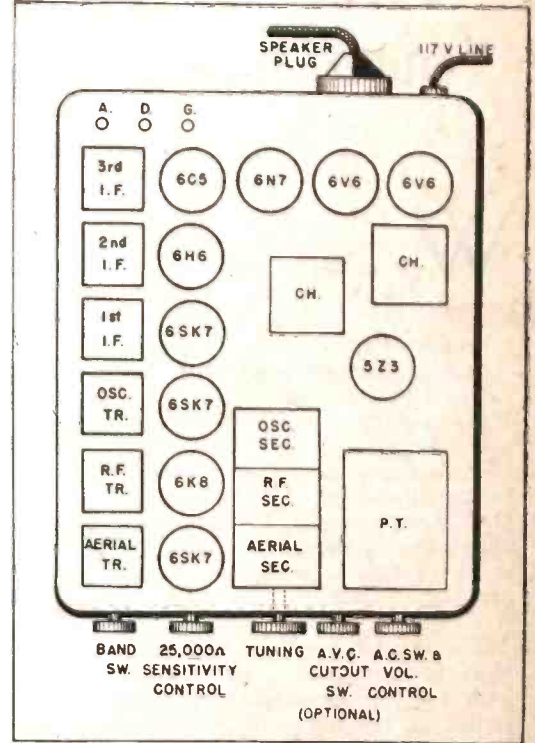

The complete diagram of Mr. Emmett's receiver is shown at top of page. Above is the chassis layout and below, the power pack.

formers, so the output I.F. is an air core—still a Meissner though. The usual practice, where three I.F. transformers are used, is to put the air core type in the first stage to lessen feed-back tendency, but I seem to notice an advantage in reversing the standard procedure, getting a maximum of am-

(Continued on page 174)

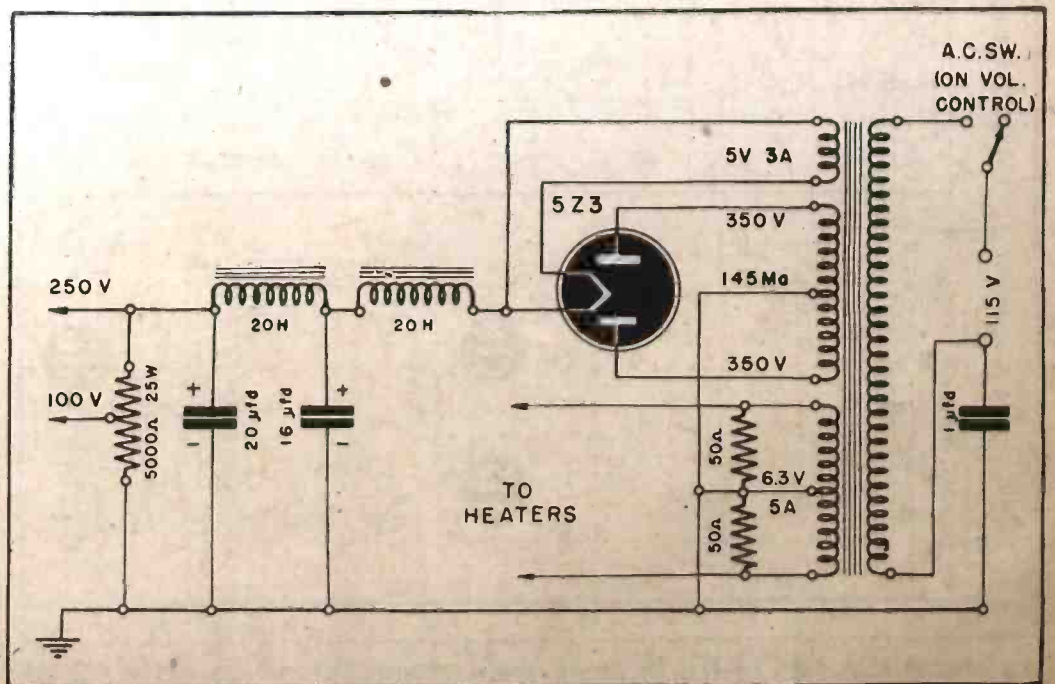

THE "HOMEBROADCASTER"

By ARTHUR W. CRAMPTON, JR.

It is hard to realize how much fun can be had and how much can be added to the variety of home entertainment by "homebroadcasting." All you need is a microphone, a record player and some method of attaching them to your radio. If you want your program to have the last touch of realism, why not build your own radio station? This will enable you to tune in your own programs on the radio just as you would any commercial broadcast station.

The power of your "station" must of course be small to comply with FCC regulations (see "Illegal Record Players," *Radio-Craft*, December, 1943). The construction is simple.

Your microphone can be crystal, dynamic or velocity. I have secured fine results by using a PM dynamic speaker of the 4 to 6 inch type. If such a "microphone" is used, it should be enclosed in a box which will just hold it. The back should be left open. The record player may be any commercial unit or a home-made affair.

The transmitter itself consists of a 6A7, a 6J7 and an 80. The 6J7 is the pre-amplifier, the 6A7 the oscillator and the 80, of course, the rectifier in the power supply.

The unit should be made as small as possible without cramping. All the parts used can be obtained from a couple of discarded radios. The diagram shows all the connections which must be made and is easily followed. The values of all constituents should be followed exactly, as a few of them are more or less critical.

The variable condensers are trimmers taken from an old I.F. coil (easily retrieved from a discarded superhet). The coil consists of 100 turns of No. 28 wire on a 1½-inch form. Don't use more than 10 feet of aerial and never connect an outside antenna to your station, as the range will be too great and you will cause interference with your neighbors' radios. Violations of this type are looked upon very seriously by the Federal Communications Commission. The legal range is equal to 157,000

f (Kc), the answer being in feet. It is better to tune the oscillator to a point near the low-frequency end of the broadcast band, for the farther up on the spectrum the tuning point is moved, the shorter becomes the permissible range.

The complete station is then set up on a large table near a wall, in some other room than the one in which the radio is located. Thus people will hear the program just as from any other station. The table should be big enough to accommodate the transmitter, microphone, record player, records and any miscellaneous things such as sound effects. You should assign call letters to your station, for further realistic effect. With a Turner 33X crystal microphone and an Astatic FP 18 crystal pickup, the reproduction in the big radio in my living room was equal to that of any standard broadcaster.

There are numerous ways in which this device may be used to liven up a dead evening. Many devices and stunts can be given just that extra touch required to glamorize them by broadcasting. For example, if members of your family or some of your friends are musically inclined, you can practice up a few numbers and give a

concert. The "band" get just as much fun out of it as the audience. We have a guitar and a mandolin here. They make a good combination and sound well over the air.

Another angle which can be worked in during intervals is the "transcription." Play a record, then go on the air with an "advertisement." If well done, a good deal of comedy can be introduced here. Members of the audience can hear themselves quoted in testimonials "for Schlaugnehofer's Celebrated Shingles, which can be used for flagstones, dinner-plates, footwarmers—and even on the roof." There is real fun in this, especially if you have one or more members in the party who do not know that the "station" is not one of the regular commercials.

Quiz programs are a very interesting feature, and provide plenty of fun. You can make up your own quizzes, patterned after those heard on the air. The added air of mystery created by broadcasting makes a success of many stunts which might be uninteresting as mere parlor entertainment.

Contests can be staged, and other stunts pulled. In fact, we have never reached the limit of our possibilities, with the whole technique of broadcasting to draw on for our inspiration.

Machining operations involving irregular surfaces, such as propellers, dies and cams, have in the past often required expensive and time-consuming hand labor—chipping, grinding, polishing.

A new tracer mechanism, with the Westinghouse Silverstat regulator as its operating medium has already been applied successfully to several such operations. In operation, a probe, mounted in connection with the Silverstat, is used to follow the contour of an accurate model—either actual size or to scale. As the probe is moved across the model, it affects the position of the Silverstat. Through an electronic amplifier, the cutting tool is moved correspondingly.

The accuracy of the tracer mechanism is such that, with a well designed machine tool and an actual size model, the contour of the model can be duplicated within two or three thousandths of an inch when feed speed of twenty to thirty inches per minute is used.

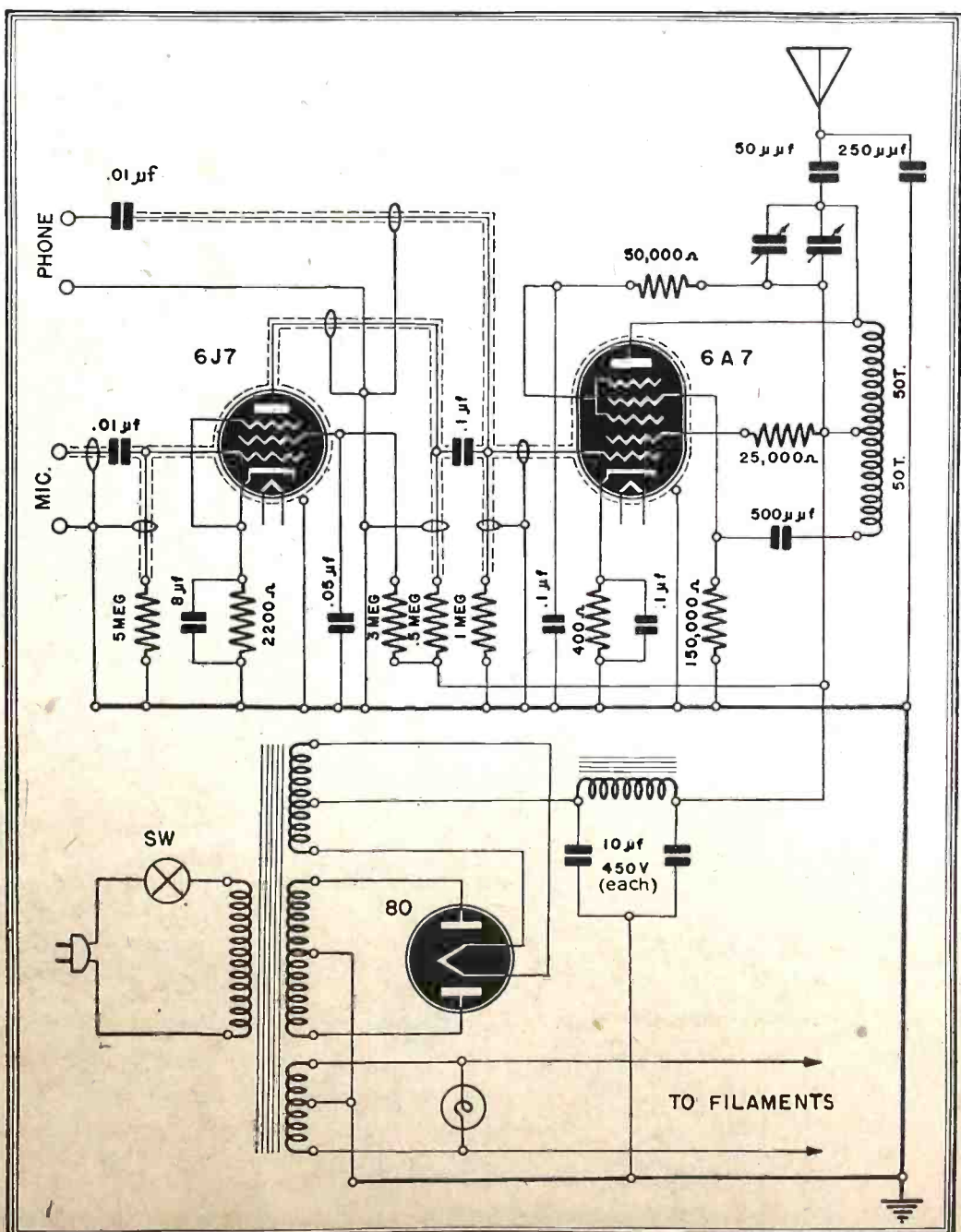

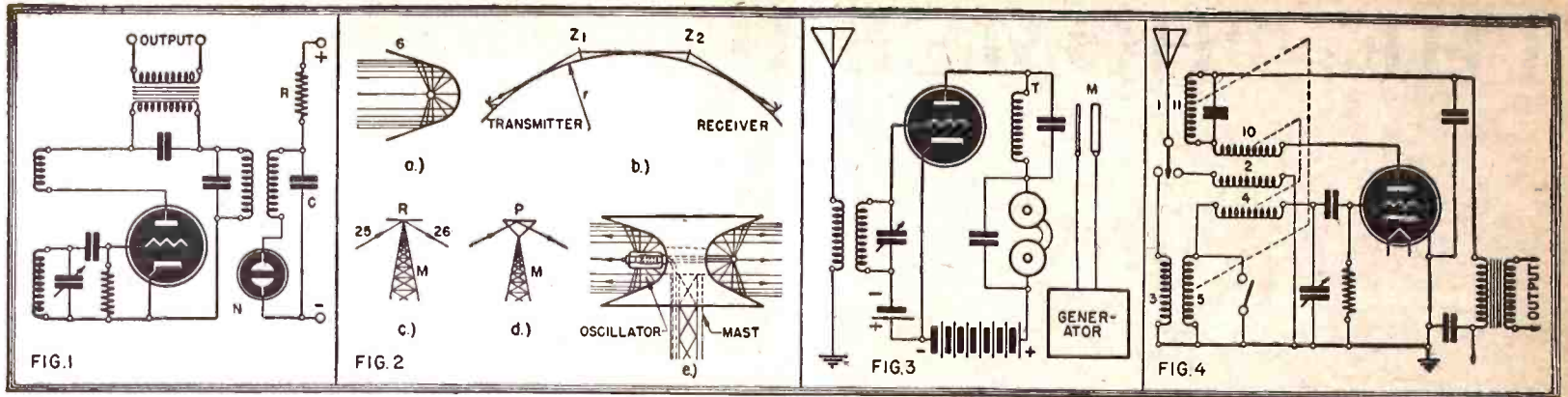

The confiscated patents range from superregenerative receivers and multi-band circuits to overland directional control of radio waves.

ALIEN ENEMY PATENTS

Are Available to American Manufacturers at Low Cost

By I. QUEEN

ALL enemy alien property is now in the hands of the Alien Property Custodian, as is well known. This property includes thousands of patents owned by enemy aliens. These patents are now available to American industry and business at a cost of only \$15.00 each, use of them being non-exclusive and to exist for the duration of the patent involved.

Many of these patents are basic and useful in all branches of science and industry, not only during the war but for post-war years. In order that they may be widely utilized as an aid to war industries, our government is desirous of making known these patents so that those in a position to make use of them may do so. To this end, *Radio-Craft* is here listing a number of interesting inventions which relate to the electronics field. The following patents are all of German origin, though the custodian also has a number of Italian patents in his charge. Readers may find it interesting to compare foreign inventive genius with our own.

SUPERREGENERATIVE RECEIVER

Patent No. 1,931,950

It is usual in a superregenerative receiver to provide a separate oscillating circuit at a super-audible frequency using an electron tube. The disadvantage of another tube and its filament power is overcome by making use of a glow tube, such as a neon bulb, shown at N in Fig. 1. R and C are chosen to provide a blocking frequency which is transferred to the oscillating circuit by T.

INFLUENCING RADIATION

Patent No. 1,939,345

WE usually think of radiation as being uncontrollable once it has left the antenna. Since radio waves may be reflected and refracted by either a solid metallic wall or a closely spaced system of wires, their direction may be varied in a similar manner to that of a light beam. The higher the frequency, the simpler it is to control them.

Original transmission of the UHF beam may be made by placing the antenna at the focus of a circular parabolic reflector, the beam taking the form of a plane surface (Fig. 2a). Now due to earth curvature, this plane finally rises to a height beyond reach. By placing reflecting surfaces at regular intervals (Z in Fig. 2b) the original beam may be transmitted to any required distance. Reflection (Fig. 2c) or refraction due to a prism effect (Fig. 2d) may be utilized, or the beam may be simply transferred by a conductor from the focus of one parabolic surface to another (Fig. 2e). In this way UHF carrying television or FM may be relayed from one city to another. Maximum use is made of low power by using narrow beams, besides allowing reception in deep valleys.

SUPERREGENERATION

Patent No. 2,010,978

SUPERREGENERATION provides the most sensitive circuit thus far devised. Theoretically unlimited amplification is available at the proper point of operation. In most cases the blocking frequency is the result of impedance changes in the circuit, resulting in broad tuning and noise.

This invention makes use of periodic detuning at about 15KC. A condenser microphone M is connected to a generator and its vibrating

diaphragm influences the total capacitance of the tuning system (T) thus detuning it at a super-audible rate. Normally both tuning circuits are resonated thus causing oscillation (tuned-plate, tuned-grid circuit). See Fig. 3.

MULTI-RANGE RECEIVER

Patent No. 2,052,686

IT is sometimes difficult to design a regenerative receiver to respond to ranges widely separated, since switching must usually be made in the tickler coils. In Fig. 4, coils 5 and 11 are coupled, as are coils 2, 4, and 10, also 3 and 5. For short waves coil 5 is shorted out and the antenna connected to coil 2. Therefore, 2 is the antenna coil, 4 the grid coil and 10 the plate coil. For long waves coil 3 is the antenna coil, 5 and 4 the grid inductance and 10 plus 11 are the plate coils, the antenna having been switched to coil 3. Plate coil switching is thus entirely eliminated.

OBJECT DETECTOR

Patent No. 2,089,677

HERE is a very sensitive device for detection of objects. A gas discharge tube is used in conjunction with an external "antenna," Fig. 5. The tube should have a diameter of about 1/5 the length for most sensitive results. Argon at about .6 mm. pressure is used and a voltage of about 30 impressed between anode and cathode. The external electrode is supplied with 1000 volts, causing about 1 ampere to flow in the anode circuit, in the discharge state. Spacing between external electrode and tube is decreased until the discharge just stops. Now any object coming into the field especially between antenna and tube causes discharge to return. It is possible to detect objects about 6 ft. from the system.

SPACE-CHARGE-RECEIVER

Patent No. 2,090,051

A SPECIAL tube is used in this receiver to operate a speaker, either on radio or records. It is necessary to use a tube whose plate current varies about 20 MA per grid volt. This requires very close grid-cathode spacing, which normally results in difficulties. The tube used (Fig. 6) employs additional grids interposed between cathode and control grid. The inner grid regulates the emission of electrons, the outer grid accelerating them. The screen grid between them is for shielding. The result is a combined voltage amplifier and power tube.

UHF RADIO

Patent No. 2,092,069

FOR either receiving or transmitting this circuit (Fig. 7) provides simplicity and efficiency. The loop is a combined antenna and tuning coil, a sliding contact arm serving as regeneration (or oscillation) control. Z is either headphones, modulating device or keyer, depending upon circuit function.

UHF REFLECTOR

Patent No. 2,118,419

THIS is an ingenious idea for providing more sharp and efficient radio beam reflection. In Fig. 8 the antenna is placed at the focus (F). (Continued on page 178)

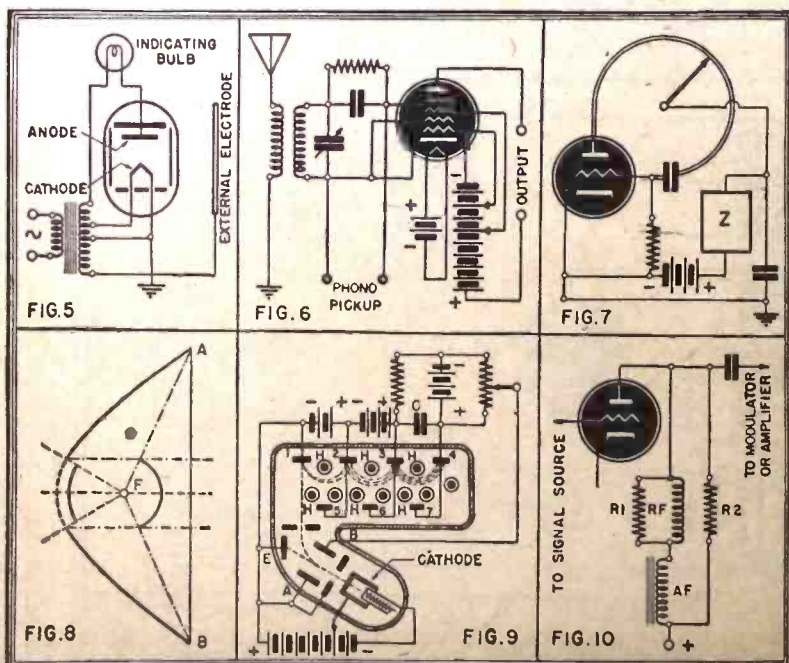
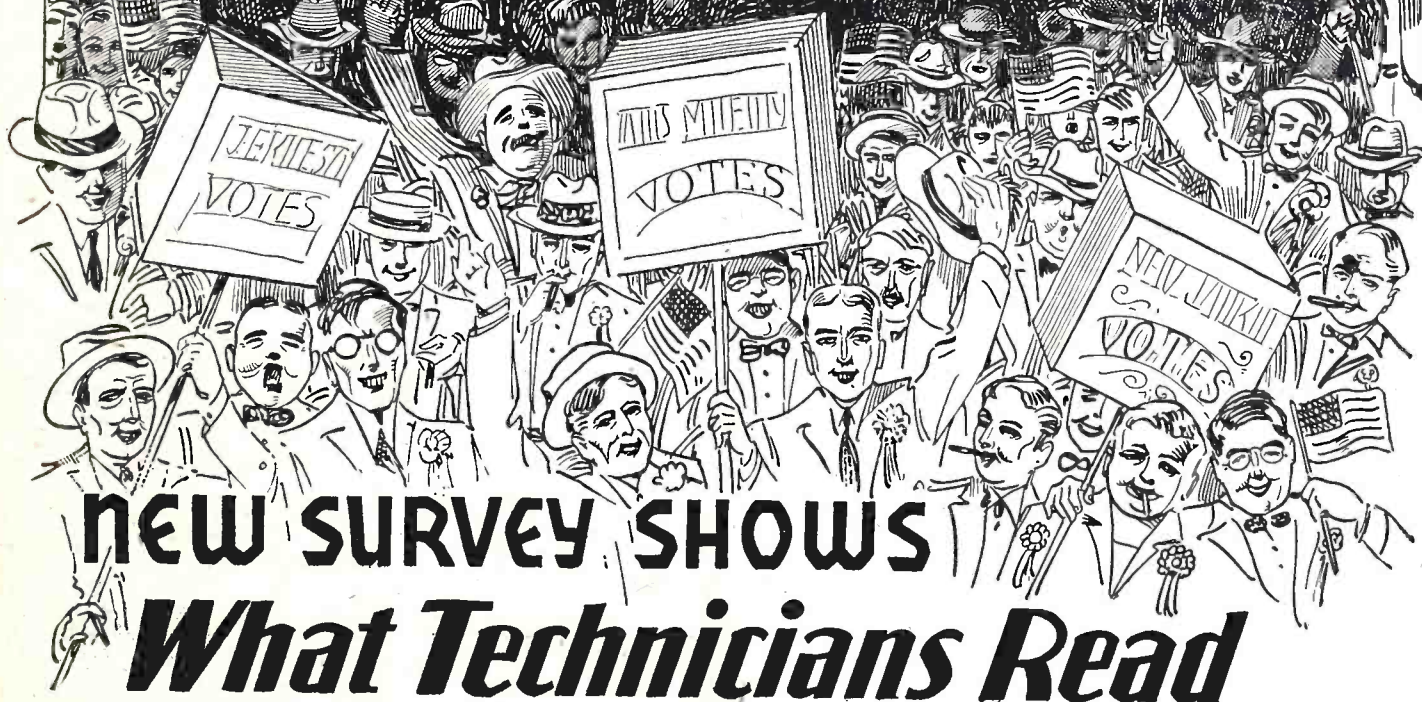

Fig. 5—An intrusion detector. Fig. 6—A space-charge circuit. Fig. 7—Ultra-high-frequency transceiver. Fig. 8—UHF reflector. Fig. 9—Bent electron multiplier. Fig. 10—A relaxation oscillator.

The 1st 2nd and 3^d Choice in RADIO and ELECTRONICS



NEW SURVEY SHOWS *What Technicians Read*

FREE TO MANUFACTURERS AND WHOLESALERS

THE radio and electronic electorate have spoken. A nationwide poll shows which are the favorite magazines among technicians.

As was to be expected RADIO-CRAFT is away out in front. It was quite a revelation to learn who are the 2d and 3d Choices, also the rank of other publications in the procession.

This is all told in the Survey just completed. Other valuable information about the radio and electronic field is also brought out graphically in this report. Send for the Survey and our booklet: LOOKING AHEAD IN MERCHANDISING ELECTRONICS AND RADIO.

Fill in coupon
or write for
Survey on your
own letterhead.

RADIO-CRAFT, 25 WEST BROADWAY, NEW YORK 7, N. Y.

Kindly send me a copy of your "SURVEY OF THE RADIO-ELECTRONIC FIELD" together with your booklet "LOOKING AHEAD IN MERCHANDISING ELECTRONICS and RADIO." (Sent free to manufacturers and wholesalers only—10c to others.)

Name Title

Company

Street P. O. Zone No. State

New Radio-Electronic Devices

MULTI-CELLULAR SPEAKER

Altec Lansing Corporation
Hollywood, Calif.

COMBINING both high and low frequency units in a compact two-way multi-cellular loud-speaker requiring less than one and one-half cubic foot of space, this speaker provides a point source of high quality sound for monitoring, radio, public address and recording.

The voice coil of the high frequency horn is wound with rectangular aluminum wire and operates in a magnetic field of very high flux density, which is supplied by a recently perfected type of permanent magnet. The aluminum alloy metal diaphragm provides mass stiffness and high velocity of transmission speed at least five times greater than through paper cone material. This high frequency unit is designed to operate as a piston up to frequencies above the limit of audibility. The high frequency horn is a multi-cellular unit having six cells in a 2 x 3 configuration. Each cell covers a 20° solid angle, which means a combined area of distribution in the horizontal plane of 60° and 40° in the vertical plane. The high frequency horn is covered with a sound deadening material and mounted in the face of the low frequency unit.

The three-inch voice coil of the low frequency unit is also wound with rectangular wire. Both the voice coil construction and the magnetic circuit design aid in delivering a very high efficiency. The low frequency voice coil assembly is mounted in a 15" stiff paper cone resonant at 38 cycles.

The input impedance of the duplex speaker is 20 ohms and a dividing network of the constant impedance type is used with a crossover frequency of 1200 cycles for separating the power for each unit.—*Radio-Craft*



COMPARISON BRIDGE

Industrial Instruments, Inc.
Jersey City, N. J.

THIS production-test instrument is an AC slidewire bridge with vacuum-tube null indicator arranged so that resistors, capacitors or inductors can be compared with a similar standard. Ranges are: Capacitance, between .0001 and 1.0 mfd.; Resistance, between 2000 ohms and 20 megohms; Inductance, between 5 and 50,000 henries. The slidewire is uncalibrated; external standards are used. In use, after the instrument is set up, the resistors, capacitors or inductors under test are connected one by one to the "X" terminals and are then rejected or passed by a direct reading of the indicating meter. Components outside the limits set up

will result in a meter deflection greater than a set value. Operation is simple and rapid as the operator reads the meter directly, without rotating dials or pressing buttons. Limits may be set with any combination of high or low value, such as minus 6% plus 14%.

The instrument comprises the main unit with separate meter on stand, the former measuring 7 x 8 x 5½ inches. Net weight, 6 lbs.—*Radio-Craft*

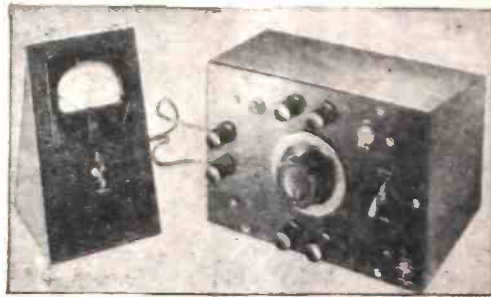

NEW FLUXMETER

General Electric Co.
Schenectady, N. Y.

THE FLUXMETER, applicable wherever permanent magnets or D.C. electro-magnets are used, is similar to a light-beam galvanometer and has a suspension-type element. By using search coils, which can easily be constructed by the user, it provides a ready means of handling a wide variety of magnetic measurements. It can obtain different sensitivities by utilizing galvanometers of various characteristics. These galvanometers are interchangeable, and the instrument has a scale of 50 0 250 millimeters.

The control box, which contains a dry cell, resistors, rheostat, push button, and a switch, provides a means of introducing a voltage into the electric circuit to compensate for small but undesirable spurious voltages that may otherwise cause errors in high-sensitivity instruments of this type. Moreover, the control box provides a means of returning the spotlight index to the zero position after a measurement has been made.

This compact instrument for measuring magnetic fields which occur in research, testing and production work, depends for its operation on the use of a direct current, moving coil galvanometer of the "compensated" type. In this design, the restoring torque of the suspension is, for all practical purposes eliminated, resulting in a fluxmeter construction which is excellent for work with electric measuring instruments, communication apparatus, motors and generators and contactors and relays. After a flux change has been indicated, the light beam index remains at the point, giving ample time for accurate readings.—*Radio-Craft*

TWO-CIRCUIT RELAY

R. W. Cramer, Inc.
Centerbrook, Conn.

THE new Cramer Type TDSA and TDSB Time Delay Relay has been designed to provide a definitely varied operation of one circuit in relation to the second circuit. It is arranged for surface mounting for either front or rear connections and is especially designed to withstand momentary shock conditions.—*Radio-Craft*

WIDE-RANGE OSCILLOGRAPH

Allan B. Du Mont Labs., Inc.
Passaic, New Jersey

DUMONT Type 248 is a portable instrument suitable for lab or production-test purposes. Two units—the oscillograph and the power supply connected by a 6-foot plug-in shielded cable—facilitate handling and installation. A removable cover protects the oscillograph panel when instrument is not in use. The power supply weighs 80 lbs.; oscillograph, 30 lbs. Units each measure 14 x 18 x 21 inches deep.

This instrument reproduces either transient or recurrent phenomena. Also accommodates phenomena of inconstant repetition rate. Leading edge of short pulses is not obliterated. The accelerating potential applied to cathode-ray tube is great enough to permit study of extremely short pulses with low repetition rates. Timing markers are available for quantitative or calibration purposes.

Among the interesting features of this oscillograph are: Wide band vertical axis amplifier usable to 10 MC. 4000 volts accelerating potential applied to cathode-ray tube, allowing observations of fast writing rate phenomena. Extremely flexible time base generator to display signals which heretofore required special sweep circuits. Delay network in vertical channel, permitting observation of entire wave shape of short-duration phenomena. Useful timing oscillator for quantitative analysis. Trigger output signal useful for "synchroscope" applications.—*Radio-Craft*

GLASS-TO-METAL SEALS

Sprague Electric Co.
North Adams, Mass.

THE old problem of guarding various capacitor and resistor types adequately against leaks and moisture is solved by this unique glass-to-metal seal. In the case of capacitors, the usual ceramic terminals are supplanted by those of glass. These glass bushings are then sealed direct to the metal capacitor container, and do not require adjacent metal rings with "matched" temperature coefficients of expansion. On Koolohm Resistors, the resistance unit is encased in a special glass tube which is sealed directly to the metal ends. The resulting seals make glass and metal a solid, integral unit, and are leak-proof, shock-proof, and humidity-proof.

Seal sizes range from very small up to 3" in diameter. They work equally well on practically any metal including steel, brass, and monel metal. So far-reaching has the development proved in its importance that Sprague Capacitors and Koolohm Resistors utilizing glass-to-metal seals are now available in 8,000 different electrical combinations.—*Radio-Craft*



HOGARTH DOESN'T MIND—HE'S USED TO HAVING
A CROWD AROUND HIS **ECHOPHONE EC-1**

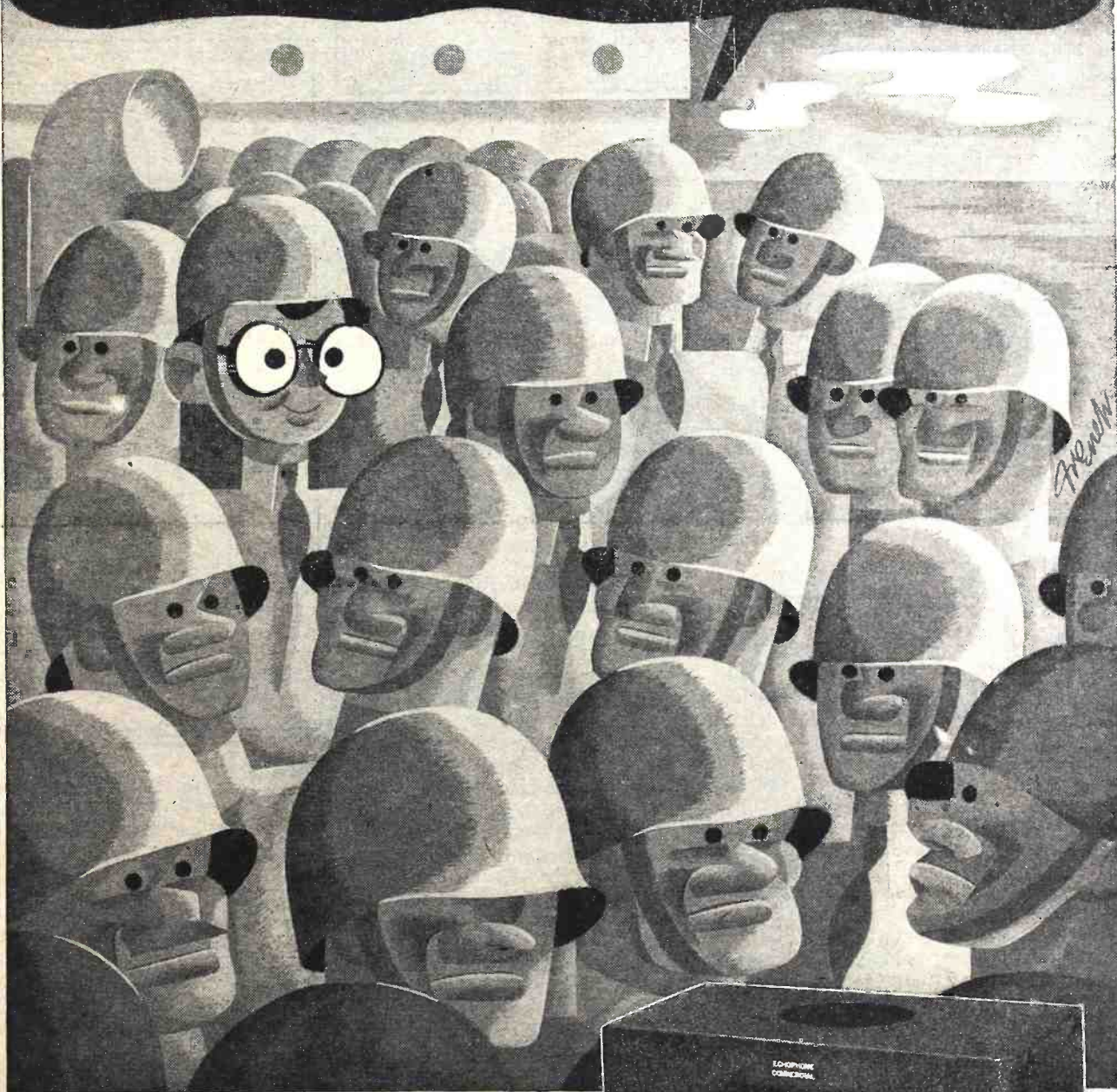

ECHOPHONE MODEL EC-1

(Illustrated) a compact communications receiver with every necessary feature for good reception. Covers from 550 kc. to 30 mc. on 3 bands. Electrical bandspread on all bands. Six tubes. Self-contained speaker. 115-125 volts AC or DC.



ECHOPHONE RADIO CO., 540 NORTH MICHIGAN AVE., CHICAGO 11, ILLINOIS

Radio-Electronic Circuits

TUNABLE OSCILLATOR

I have tried many code practice oscillators and could not find one which would include easy tuning, a large but effective variety of pitches, and—last but not least—low cost and simplicity.

The diagram below is an oscillator which I discovered while trying to improve the popular type which uses a type '30 tube. A large variety of tones can be produced by changing the capacity of the condenser across the audio transformer. For different

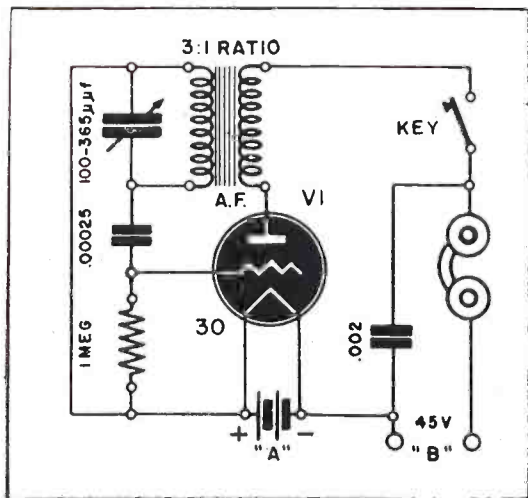

transformers it may be necessary to change the value of the grid condenser and leak.

A 1.4-volt type such as the 1G4 should work well in this circuit, although I have tried only the '30. One of the great advantages of the set is that while it works much better than the old oscillator, it is almost as quick to throw together.

WAYNE McCLUNG,
Albany, Georgia

MIDGET POWER SUPPLY

This B-power supply for an R.C.A. personal radio was made to take the place of the 67½-volt battery. It can be made to fit in where the battery was. No attempt was made to build a filament supply as the flashlight cell is always available.

It was built on a flat piece of bakelite 3½ x 1¼ x ¼ inch. The midget choke and the 6H6 socket (a wafer type lifted on ¼-inch spacers) are mounted on this panel. A dual 8-mfd condenser is also mounted on the panel and strapped to the choke. The other parts are mounted between the

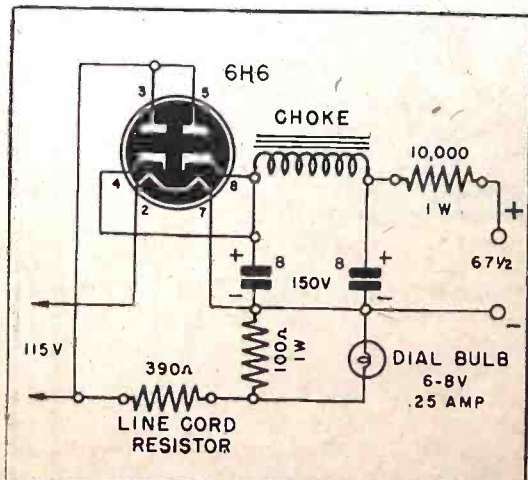

RADIO-CRAFT welcomes new and original radio or electronic circuits. Hook-ups which show no advance on or advantages over previously published circuits are not interesting to us. Send in your latest hook-ups—RADIO-CRAFT will extend a one-year subscription for each one accepted. Pencil diagrams—with short descriptions of the circuit—will be acceptable, but must be clearly drawn on a good-sized sheet of paper.

tube and condenser. The top of an old 67½-volt battery was removed and fastened on the end so the power supply can be readily disconnected whenever it is desired to use a battery again.

For larger portables requiring up to 90 volts, the 10,000-ohm resistor may be omitted or reduced as required. Another 8-mfd. condenser across the output of the power supply may be necessary to prevent oscillation in some receivers, and could do no harm in any of them, if there is sufficient space.

A hole has to be drilled through the panel for the guide pin of the 6H6. The pilot light is installed so the set won't be left on. A hole can be drilled through the removable back of the set for the cord of this power supply.

FLOYD E. SMITH,
San Francisco, Calif.

CAPACITY OPERATED RELAY

This relay operates on an increase in capacitance across the grid coil, so that oscillation is reduced and plate current increased. The relay, used should be very sensitive. Point A connects to any large metal object, point B to ground.

The relay is adjusted so that at the point of oscillation, it just opens. A person approaching the large metal plate causes an increase in capacitance, throwing the circuit out of oscillation and closing the relay. A meter or phone may be used to indicate oscillation.

This circuit may be used to protect a safe, a motor car or any other large metal object. In the case of a car, a ground chain would have to be used at point B.

HAROLD NEWELL,
Bradford, N. H.

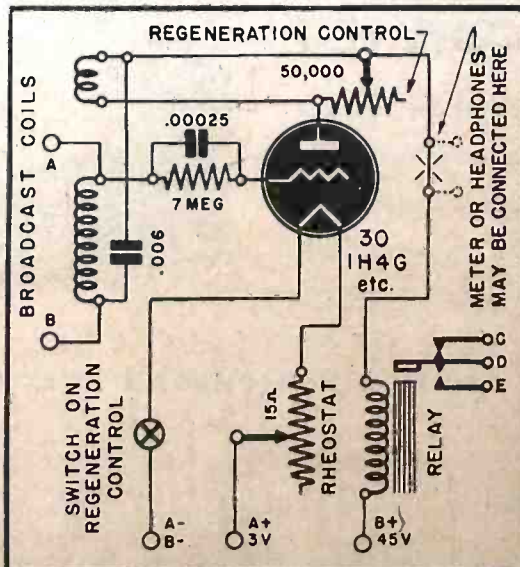

AN OSCILLATOR-AMPLIFIER

A combination audio oscillator and audio amplifier using a 1D8-GT is given in the diagram. The 4-position switch, a tone control switch with stop pin broken off, gives three audio tones with no oscillation in the fourth position. In this fourth position and with the input jacks, the tube is used as an amplifier.

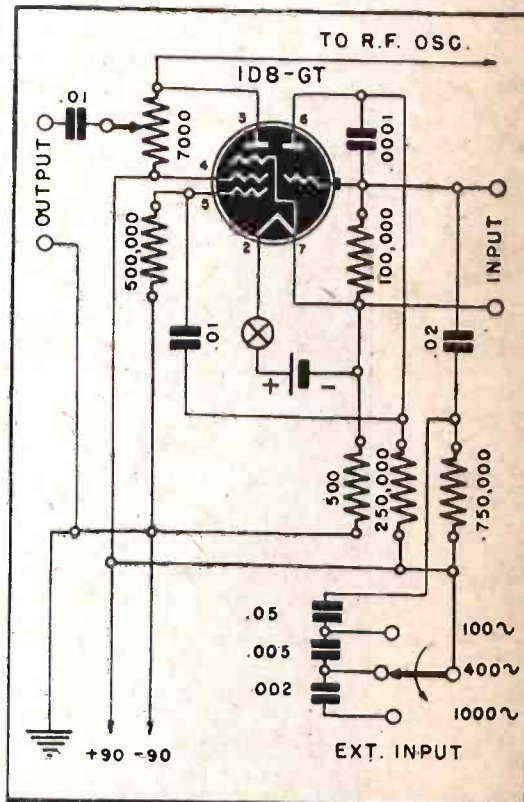

This circuit is being used in a test oscillator and is used to modulate a 3Q5-GT in the radio frequency part.

GUY O. BUCKNER,
Houston, Texas

1-TUBE SUPERHET

Using the multi-element 1D8, I have designed a superheterodyne which is far superior to a regenerative receiver.

The pentode section is the R.F. amplifier-mixer, the triode is the oscillator and the diode plate a detector. T2 is the oscillator coil, T3 the I.F. transformer, and C1-C2 may be ganged. C3 and C6 are padders.

C3 may be omitted in most cases, the rotor of C1 being connected direct to ground. Alignment troubles will be saved if C1 and C2 are not ganged, but tuned independently.

MAX W. SCHMUCKLER,
Pueblo, Colo.

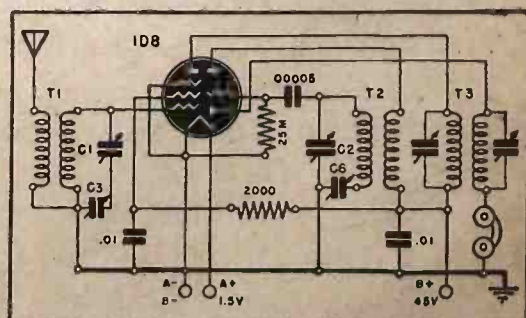

SPRAGUE TRADING POST

A FREE Buy-Exchange-Sell Service for Radio Men



*** FLEXIBLE**

*** MOISTURE PROOF**

*** HEAT-PROOF TO 1000°C.**

*** LARGER WIRE SIZES IN LESS SPACE**

The ONLY Resistors wound with * CERAMIC INSULATED WIRE!

As a radio serviceman, no one has to tell you that a wire wound resistor is no better than its insulation—or that that is why Sprague Koolohm Resistors are "tops" by any test you care to name. Koolohm ceramic insulation is applied directly to the wire and the assembly is then DOUBLY protected by an outer ceramic tube. Koolohms operate so cool you can use them at full wattage ratings. They are highly resistant to both moisture and heat. They give you higher ratings in smaller sizes. KOOLOHMS will not let you down!

FOR SALE—Servicing Superheterodynes (Rider), Principles of Radio (Honey-4th edition), and Radio Amateur's Handbook—all for \$5. W. B. Foster, 151 Wellington, Columbia 32, S. C.

WANTED—Multimeter, Echophone PC-1 receiver, and TB4's. Clifford E. Jenkins, Jr., 171 Homestead Ave., Holyoke, Mass.

WANTED—New or used tubes; also table model radios with or without tubes. Variety Radio Service, 556 Third Ave., New York 16, N. Y.

WANTED—Late model tube checker, V-O-M and sig. generator. George Ival, 345 W. 111 St., New York City 23, N. Y.

FOR SALE—One each of the following tubes (most in sealed cartons): 80, 88, 17, 25Z6, 6F7M, 5Y3G, 6AG, 6AR6T, 6K5GT, 6J5, 6BS, 6N7, 6SA7, 2X1, 6SK7, 6NS, 1G4G, and 90. R. H. Bailey, Huntsville, Ont., Canada.

WANTED—Set analyzer, sig. generator, or any testing equipment. J. C. Wallen, 4824 Pendleton, San Diego 9, Cal.

URGENTLY NEEDED—Supreme No. 585 diaphragm and all types test equipment. Watts Radio Shop, Box 49, Smiths Basin, New York.

FOR SALE—G.E. 300-0-600 v. A-C No. AS-2 meter with slightly used leather carrying case. Want 150 v. A-C meter or what can you offer? H. W. Gould, New Iberia, La.

WANTED—RCA Junior voltohmmyst or similar electronic volt-ohmmeter. Harvey Schneider, 9408 Avenue A., Brooklyn, New York.

WANTED—Up-to-date tube tester and sig. generator. Cecil Fehmler, Doyleburg, Pa.

FOR SALE—Radio City No. 307 tube tester, \$39; A-21 UTC transformers, \$5 ea.; 128L7 and 6K5 tubes, in good condition; and 2-watt resistors. W. L. Thiel, 96 Westbury Blvd., Hempstead, N. Y.

FOR SALE OR EXCHANGE—Motorola Golden Voice No. 80 car set, Dayrad Raytheon No. 92 tube testers, castings for making wood lathes and new complete outfit for making glass signs. Want multimeter or combination, power output tube tester, Clough Brengle CRA scope or similar. Glenn Wait, Chanute, Kansas.

URGENTLY NEEDED—Radio tester. Richard Sheard, R.F.D. 6, Box 24, Navy Yard, Charleston, S. C.

FOR SALE—Hallcrafters SX-25, with speaker and extra set of tubes. Perfect condition. Pvt. Buddy Echestein, 101 Burr Road, San Antonio, Texas.

WANTED—Up-to-date tube tester, sig. generator, test equipment, and shop stock. Harry Galewski, 216 Center St., Winona, Minn.

FOR SALE—Slightly used Webster W-1295 de luxe Intermix record changer and recorder. Warren Waterman, 49 Walkill Ave., Middletown, N. Y.

URGENTLY NEEDED—New or used power transformer (10 connections to chassis) and ballast tube for AC51 No. 103362-10 Clarion radio. P. A. Penta, Phelps Electric Co., 67 Main St., Phelps, N. Y.

FOR SALE OR EXCHANGE—Limited number of scarce tubes. Want 12K7, 6Q7, 1N5, 1H5, and 12A8 types. Bela B. Paine, 1186 Lexington Ave., New York 28, N. Y.

WANTED—Multimeter, tube tester, capacitor, and sig. generator, by honorably discharged World War II veteran, Richard J. Hamilton, Box 23, Birmingham, N. J.

FOR SALE—Clough Brengle OC modulated sig. generator, 50 KC to 30 MC. Factory calibrated frequency chart, \$35. R. S. Hope, Box 417, Darlington, S. C.

WANTED—Complete set Rider manuals—also Solar CB-1-60 condenser tester, Nesler Radio Service, 1072 Main Street, Dubuque, Iowa.

URGENTLY NEEDED—All kinds of up-to-date test equipment. What can you offer? William Allen, Valls creek, W. Va.

FOR SALE OR TRADE—Telephone receiver, several audio trans., 1-prong tube bases suitable for plug in coils. Want any model Readrite instruments. Ed Johanson, R.F.D. 1, Monticello, N. Y.

WANTED—Rider manuals—also two-speed recorder. Albert Foth, 422 W. 3rd St., Newton, Kansas.

FOR SALE—Two type C relay racks—837 overall, mounting spaces 70" (40 units). Wm. C. Cloninger, Box 883, Charlotte 1, North Carolina.

URGENTLY NEEDED—Oscillator and 1st I.F. coil for Majestic No. 15 Meissner port. No. 20-2411 or 20-6070, or Carron port No. D4035 or P4428. Also, Solar CB-1-60 condenser tester and pocket type V-O-M, Rider manuals 6 and 8, and 12, 25, 35, and 50-volt tubes. Louis J. Long, North Side Radio Service, 653 East 19th St., Indianapolis 2, Ind.

FOR SALE—2 Aluminum projector baffles with 2 1/2" 4V speakers; Rider Manual No. 2, Official Radio Service Manuals No. 3 and No. 4, "Modern Radio Servicing," and Shure 708A III-impedance microphone and 25' cable. Van's Radio Sales, 1718 S. Westnedge Ave., Kalamazoo, Mich.

FOR SALE—Rider Manuals 1 to 4; also good used radio tubes including 80, 26, 27, 01, 81, 50, 10, 75, 78, 58, etc. Urgently need 50Y6 tube. Clifford Dennis, 12 Terrace Ave., Walton, New York.

WANTED—Tubes, radio parts, public speaker outfits and used radios. Manchester Radio Service, 73 Birch Street, Manchester, Conn.

FOR SALE—New Clarion amplifier No. P13T, 110 v. 60 cycles. In portable case, 2-6N6 tubes in the output stage and Shure crystal hand mike included. \$100. Raymond McKeon, A.B.C. Electronic Radio Service, 14 W. 60th Street, New York City.

URGENTLY NEEDED—Late model Hallcrafters receiver, SX25, SX24, SX32, Sky Champion, or what have you? Warren Chase, Cambridge, Vt.

FOR SALE—Astatic JT-30TT crystal mike, Alex Bell, Wooler, Ont., Canada.

FOR SALE—50 radio tubes in original factory cartons 3 for \$1; also tube tester—range 30 V., \$18. W. F. Oeder, Rt. 1, Box 389 Kimmswick, Mo.

FOR SALE—Large V-O-M. The Electric Mfg. Co., Hastings, Mich.

FOR SALE—Two 1/2 h.p. elec. Frigidaire motors; Buckwheat coal blower, complete with day-nite controls, thermostat and wire; and Weston 0-200 ma. meter. Radio Shop, No. 12 Bellevue, 225 N. 63rd St., W. Philadelphia 39, Pa.

FOR SALE OR EXCHANGE—Weston No. 489 voltmeter and 11-piece set of German-made drafting instruments, used only once. Want Rider manuals and phono turntable, 78 r.p.m., Edmund H. Dean, Falls Village, R.F.D., Conn.

FOR SALE OR TRADE—New Astatic B16 Tru-tone pickup arm, never used. Will trade for cheap phono motors or a high quality microphone. Sgt. M. Yule, M.A.G. 53-S.S., Cherry Point, N. Carolina.

WANTED—Superior sig. generator; RCA Jr. voltohmmyst; also good volt-ohmmeter. M. K. Breck, P. O. Box 737, Osborn, Ohio.

WANTED—67 1/2 v. min.-max. or replacement battery, and 1R5, 354, 1R5 and 1T4 tubes. Pvt. Sol Blank, Sig. U. S. Army, Acconac, Va.

FOR SALE—New radio tubes in original cartons at 40% off—10, WD-11, 12A, 31, 40, 89, X99, 1E7, and 1B4. Torrence Radio, 2012 Madison Ave., Toledo 2, Ohio.

URGENTLY NEEDED—Type HY-123 radio tube. D. M. Crockett, 9437 S. Harvard, Los Angeles 44, Calif.

FOR SALE OR EXCHANGE—Excellent selection of tubes, condensers, by-pass coils and resistors; also portable Corona typewriter in perfect condition. Urgently need portable tube tester and condenser tester. Carl LaComb, Massena, N. Y.

URGENTLY NEEDED—Automatic record player for Zenith Radio; complete AC voltmeter 1-10; 1-25, 1-225; DC voltmeter 1-6; 1-50; 1-300; 1-600 D.C.A.M. 0-5; D.C.M. A.M. 0-4; 0-10; 0-20. The Home Radio Shop, K & 7th St., P.O. Box 102, Quinton, Okla.

WANTED—25A7-6J7 tubes, new or used; also V-O-M, Precision or Triplett, Pvt. Felix Rodriguez, Harman General Hospital, C14, Longview, Texas.

FOR SALE OR TRADE—1R5 tubes with adapters for 1A7; also 12SK7's and 12SQ7's. What have you? "J" Radio, Granite City, Ill.

URGENTLY NEEDED—New or slightly used 6C7 or 6SC7 tubes. George Strack, 532 S. Campbell Avenue, Chicago 12, Ill.

YOUR OWN AD RUN FREE!

This is Sprague's special wartime advertising service to help radio men get needed parts and equipment, or dispose of radio materials they do not need. Send your ad today. Write PLAINLY—hold it to 40 words or less. Due to the large number received, ads may be delayed slightly, but will be published as rapidly as possible.

Sprague reserves the right to reject ads which do not fit in with the spirit of this service.

HARRY KALKER, Sales Manager

SPRAGUE PRODUCTS CO., DEPT. RC-124, North Adams, Mass.
(Jobbing distributing organization of products manufactured by SPRAGUE ELECTRIC COMPANY)

SPRAGUE CONDENSERS KOOLOHM RESISTORS

Obviously, Sprague cannot assume any responsibility, or guarantee goods, services, etc., which might be exchanged through the above advertisements

*TRADEMARK REG. U.S. PAT. OFF.

TRY THIS ONE!

PROTECTION BOX

This is a fuse or protection box which we have found very handy for providing multiple outlets when a bench may have to be used as a service bench, then cleared off for a workbench, making it impractical to make a permanent installation. Other uses will suggest themselves.

With this kink, we have six outlets at our fingertips. The fuse protects the line fuses, eliminating the necessity of leaving your work to change fuses, to say nothing of the embarrassment often occasioned. Single or double fuse mountings may be used.

The pilot light gives instant notice of the blowing of a fuse, and should be a small 115-volt bulb. Dimensions of our box are given, but the size can readily be varied to accommodate parts at hand.

RENE RAMIREZ,
Attica, N. Y.

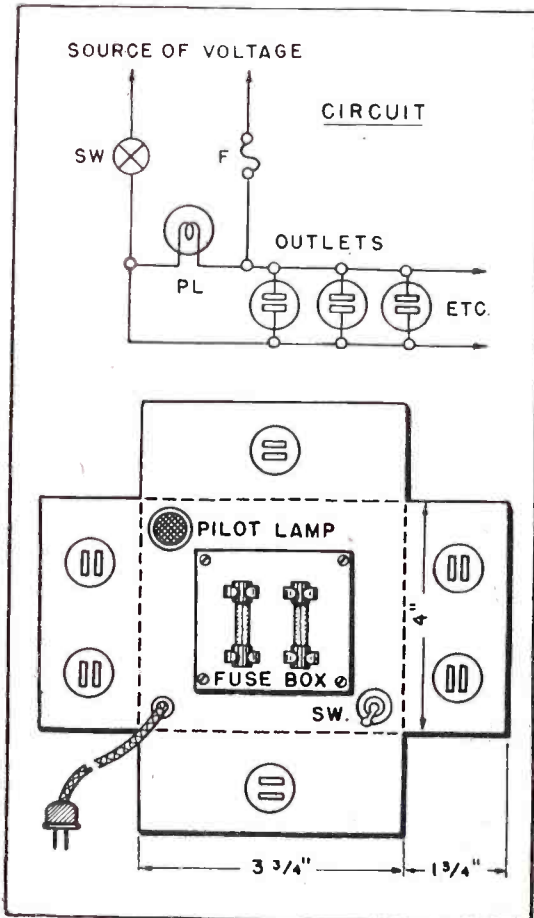

STAND-OFF INSULATOR

A miniature porcelain lamp socket is required. Dig out the wax at the bottom and remove the screw holding the brass socket shell.

Now pass a bolt up through the bottom. Put a nut and washer on to hold the bolt in place. Now we need another nut to hold down the wire.

With two of the above, a feed-through insulator can be made. A threaded rod long enough to reach the ends of both sockets is also needed. Place sockets end to end (one on each side of the panel) and put threaded rod on with a nut and washer on each end of the rod.

RICHARD PURDY,
Brooklyn, N. Y.

I.F.T. AND R.F.T. REPAIRS

When I find it impossible to get exact replacements in I.F., R.F. and oscillator coils, I unwind the defective coil to the broken place, use what is left of it and retune the circuit. It will work as well as most replacement parts.

BOB WEBB,
Greenville, S. C.

(Experience teaches that the above is true only when the break is near the outside. I.F. coils usually go in two places—where the adhesive band contacts the outside layer, and where the wire touches the form. When the break is on the outside, repairs can be made as suggested. If the open is near the middle of the coil, it is impossible to retune with the outside wire taken off. A better system—in an emergency—is to wind on, jumble fashion, approximately the number of turns taken off, then add or remove turns till the trimmers are able to control.—Editor)

AN OUTPUT TRANSFORMER

When some emergency arises and you are in desperate need of an output transformer don't worry. Just dig up an old power transformer and connect it according to the diagram.

This output transformer may be used as a push-pull output or a driver for either single or push-pull stages. In the latter case, the 115-volt winding would be the primary.

BOB WEBB,
Greenville, S. C.

(Some queer matches may be obtained from such a transformer. It is recommended that for many voice coils it might be worth while to try the two filament windings in series, comparing the results with those when one is used.—Editor)

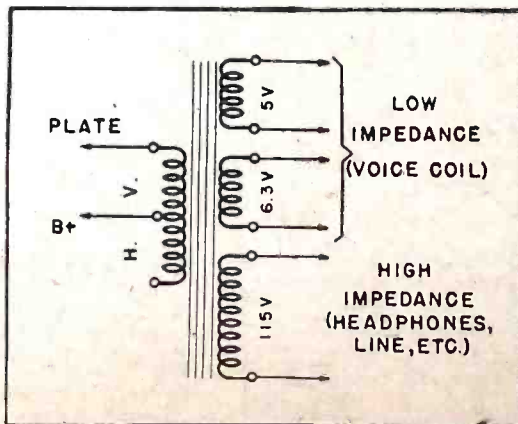

UNIQUE CODE DEVICE

I use a code practice set which requires far less parts than most of the oscillators I have seen described in *Radio-Craft*. This oscillator uses the principle of feedback which all sound men have to combat.

The picture explains everything. The battery should be of the right voltage for the microphone used. It can be plugged into the phonograph jacks of the set. If the radio has no phono jacks and is one of the type which use a diode-triode or diode-pentode detector and first audio, it is easy to attach the transformer secondary. One is connect-

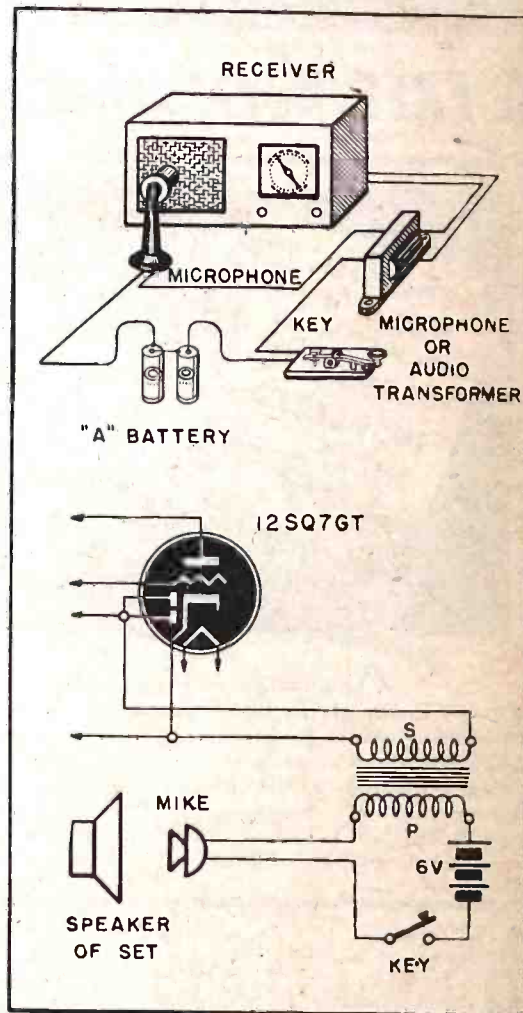

ed to the cathode of the detector-amplifier tube and the other to the diode plates. On some sets it will be found easy to attach the oscillator across the volume control.

WILLIAM MCGEE,
Baltimore, Md.

PRINT TIMER

For photographic and other uses, this timer provides an accurate, dependable circuit to determine time intervals. With switch in position 1 the tube acts as a diode, charging condenser C. In position 2, the negative bias (which cuts off plate current) slowly leaks off and the relay opens.

The timing interval (during which the relay is closed) is controlled by the 5 megohm potentiometer, increasing as the resistance of the latter.

JOHN YEAGER,
Lakewood, Ohio.

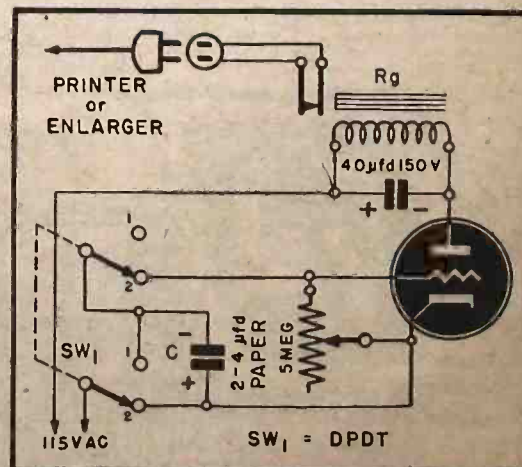

**NEW EDITION
NOW READY**

Audels RADIOMANS GUIDE

Includes **TELEVISION
AND ELECTRONICS**

LARGER - MORE COMPLETE - 914 PAGES - 633 ILLUSTRATIONS - WIRING DIAGRAMS - PHOTOS

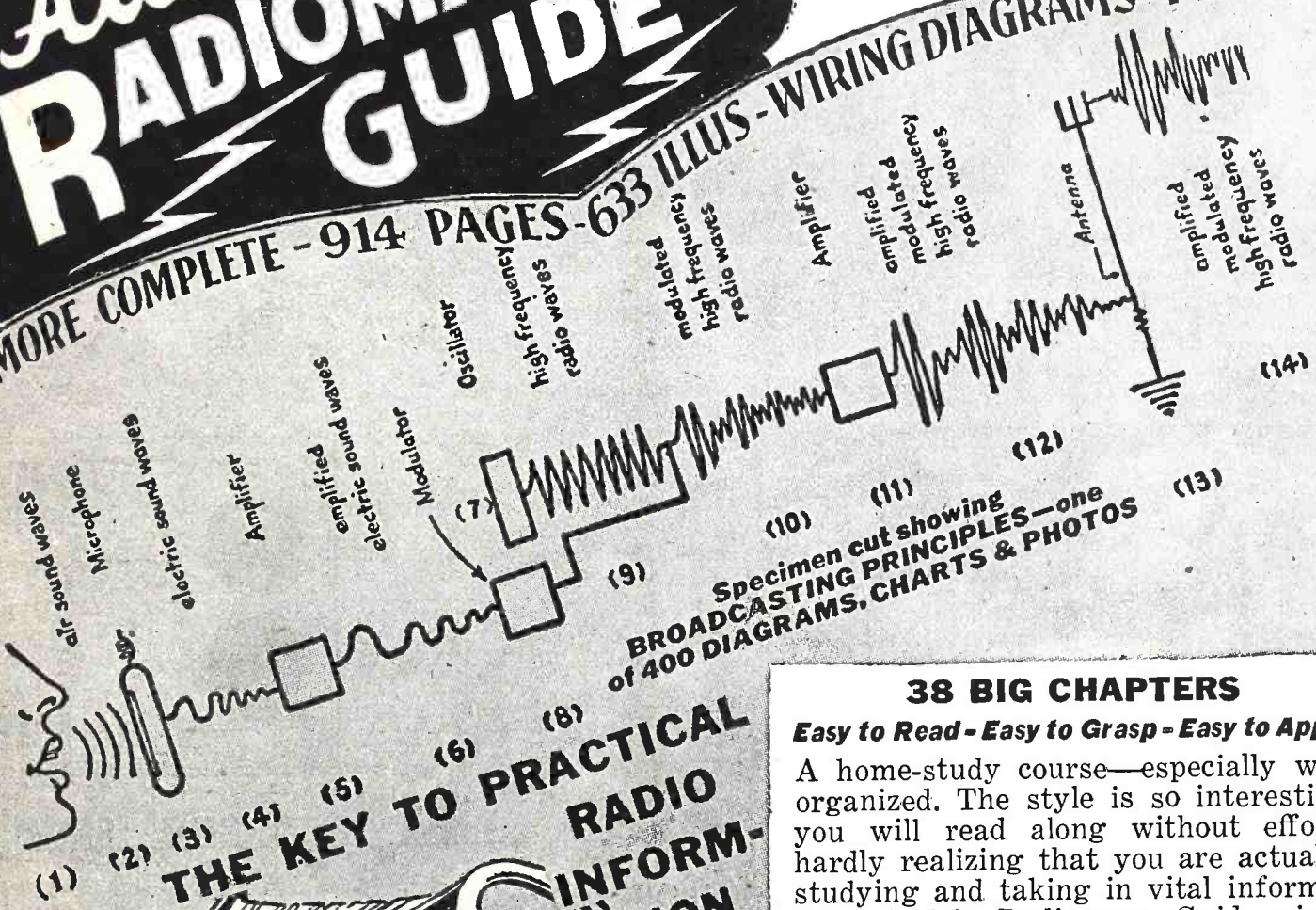

**THE KEY TO PRACTICAL
RADIO
INFORMATION**

It gives you in usable form pointers on radio, including frequency modulation, television, etc. Also valuable inside information for Aviators, Marines, Commercial Operators and Technicians, Servicemen and Students.



**Q AND A
UNIQUE
QUESTION
and
ANSWER
METHOD**

Highly Endorsed

1001 RADIO FACTS AND FIGURES

A Complete Library In One Book

AUDELS RADIOMANS GUIDE gives authentic Principles and Practices in Construction, Operation, Service and Repairs. Covers clearly and concisely radio fundamentals—Ohm's Law—Physics of sound as related to radio science—Measuring instruments—Power supply—Resistors—Inductors—Condensers—Transformers and examples—Broadcasting stations—Radio Telephony—Receivers—Diagrams—Construction—Control Systems—Loudspeakers—Antennas—AutoRadio—Phonograph Pick-ups—Public Address Systems—Aircraft and Marine Radio—Radio Compass—Beacons—Automatic Radio Alarms—Short Wave—Coil Calculations—Testing—Cathode Ray Oscillographs—Static Eliminations—Trouble Pointers—Underwriter's standards—Units and tables. REVIEW QUESTIONS—READY Reference Index.

38 BIG CHAPTERS

Easy to Read - Easy to Grasp - Easy to Apply

A home-study course—especially well organized. The style is so interesting you will read along without effort, hardly realizing that you are actually studying and taking in vital information. Audels Radiomans Guide gives you just the right amount of mathematics required to cope with radio problems successfully. You can solve, with the aid of this extraordinary book, practically every radioproblem that comes up. At your finger tips is a complete index for instant use.



7 DAYS' FREE TRIAL

THEO. AUDEL & CO., Publishers
49 West 23rd Street, New York 10, N. Y.

\$4
COMPLETE
\$1
PAY ONLY 1 MO.

Mail AUDELS NEW RADIOMANS GUIDE for free examination. If O. K. I will send you \$1 in 7 days; then remit \$1 monthly until \$4 is paid. Otherwise I will return it.

Name
Address
Occupation
Reference

**MAIL THIS
COUPON
TODAY**

THE QUESTION BOX

WIRE-LINE INTERPHONE

? Will you please furnish me with a diagram for an intercommunicator (to work with wire lines). I have a 25L6, a 6F5 and a 25Z5. Can these be used? I want an A.C.-D.C. type.—M.E.S., Girard, Ohio.

A. A simple three-tube intercommunicator circuit is shown. While a 25L6 tube is indicated, a 43 can be used equally well, if the output transformers are matched to it. A 6C5 may be substituted for the 6F5 with slight decrease in gain. By using a different line resistor, 12-volt tubes, such as the 12SF5, 50L6 and 35Z5 can be used. The line-cord resistor could then have a value of 130 ohms.

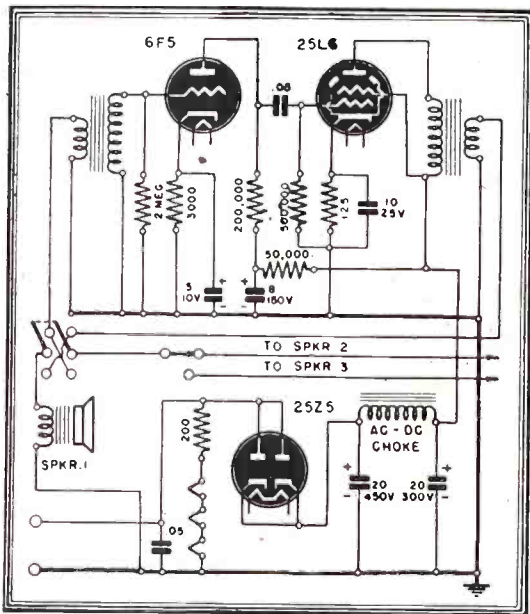

SUPERHETERODYNE TUNER

? I wish to have the hookup of a tuner which can be used with a standard amplifier. Tubes on hand are 6SK7, 6K8, 6SK7, and 6SQ7, and I would like to use them in that order as R.F., mixer, I.F. and detector. I have a set of standard superheterodyne coils and I.F. transformers.—E.W.B., Cleveland, Ohio.

A. The schematic is printed herewith. This circuit should give excellent results both as to sensitivity and selectivity. If extra fidelity is required, variable-selectivity I.F. transformers may be used, and the 250,000-ohm resistor in the detector plate circuit replaced by a 100,000-ohm unit.

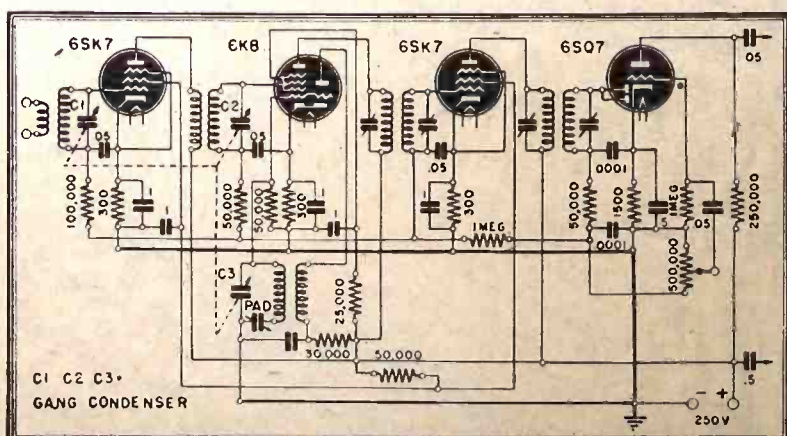

PHONOGRAPH OSCILLATOR

? I would like some information regarding the one-tube 70L7 phono oscillator described in your 1944 RADIO-ELECTRONIC REFERENCE ANNUAL, page 27. What type of coil should be used? Would an air core or adjustable iron core with a matched variable condenser work properly? They state in the description that the antenna and grid condenser are eliminated by two loops of wire coupled to the hot side of the grid coil. Just how should I make such a connection?—W. K., Dover, Ohio.

A. The best coil is an old broadcast R.F. type with a small primary. The primary is used as the plate coil or tickler, and if it is too big the set will produce a steady audio howl. The condenser which tuned it across the broadcast band is of course suitable, though some constructors save space by using an adjustable mica padder of about 150 to 450 mmfd. capacity.

The "coupling condensers" are turns of insulated wire wound tightly over the end of the grid coil. The ends of the turns are usually wrapped around the standing part to keep the turn tight, and the whole covered with coil cement. Should you not wish to bother with these, ordinary mica condensers (anything up to about 50 mmfd.) can be used with no noticeable difference in results.

A COUPLING PROPOSITION

? I have never seen or heard of a method of resistance coupling the output tubes of an amplifier to the voice coil of a speaker. Why not? Won't it work? If it will work, why isn't it used? Wouldn't it provide better quality of reproduction than output transformer coupling? A specific example is the diagram here shown.—F.C.D., Pipersville, Penna.

A. The system you show will work, but not on an 8-ohm voice coil. A somewhat similar method has in fact been used on old high-impedance magnetic speakers. The reason it will not work here is that the output impedance of the tube circuit is so high that little current will flow, and the voice-coil impedance is so low that a large current is required for any amount of power. This is what is meant by "speaker matching." Since power is volts x amperes, a very low load impedance may pass the current with such a low voltage drop that the prod-

uct of volts and amperes is practically zero. A very high impedance causes a high voltage drop but may pass so little current that the product is again near zero. It can be shown very easily that maximum power transfer exists when the load impedance is equal to that of the driving source—in this case the amplifier's output tubes. Voice coil currents in an 8-ohm coil are likely to run over an ampere. The current in this circuit would be only a few milliamperes. If you have a high-impedance magnetic speaker, this few milliamperes might produce enough power ($W = I^2R$) to make the circuit usable. A complete treatment of this problem was given in the article "Output Transformers" in the September, 1943 issue.

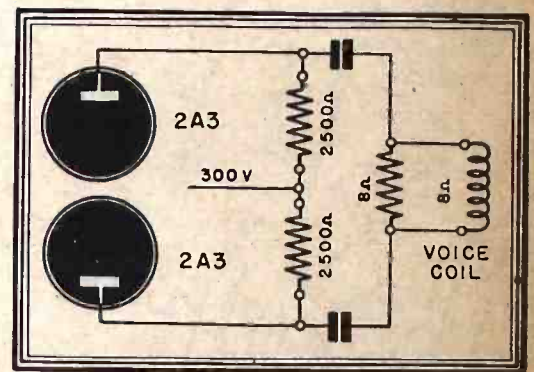

2-INPUT PREAMPLIFIER

? I would like to have a diagram for a preamplifier with two inputs, so that I can use two microphones, or phonograph and microphone, or both together, in connection with an ordinary amplifier.—T.J.R., Superior, Wisc.

A. The three-tube preamplifier shown should fill your specifications. The 6F5's will give considerable gain. It will be much better if the amplifier is operated with its own power supply, rather than being hooked to that of the larger amplifier. In the latter case hum and feedback are likely to be very troublesome. As in all low-signal-input amplifiers, shielding may be necessary to prevent hum pickup, and the power supply should be very carefully filtered.

If phonograph amplification is too great even with the volume control at a fraction of its full setting, distortion is likely to occur. In such a case, the phonograph input may be made right across one of the volume controls.

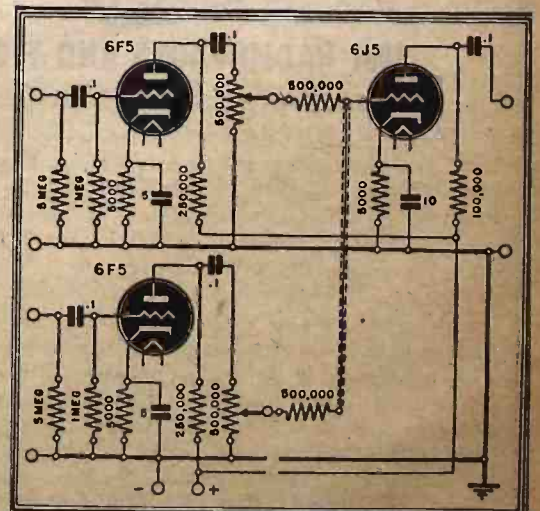

If constructed with variable band width intermediate-frequency transformers, this tuner will give excellent results with a high-fidelity amplifier. An independent power pack should be used for greater stability.

RADIO CIRCUIT MANUAL 1942

UP TO DATE OF
GOVERNMENT
SHUT-DOWN
APRIL '42

Complete, Correct, Compact

**The Set You are
Looking For Is Here!**

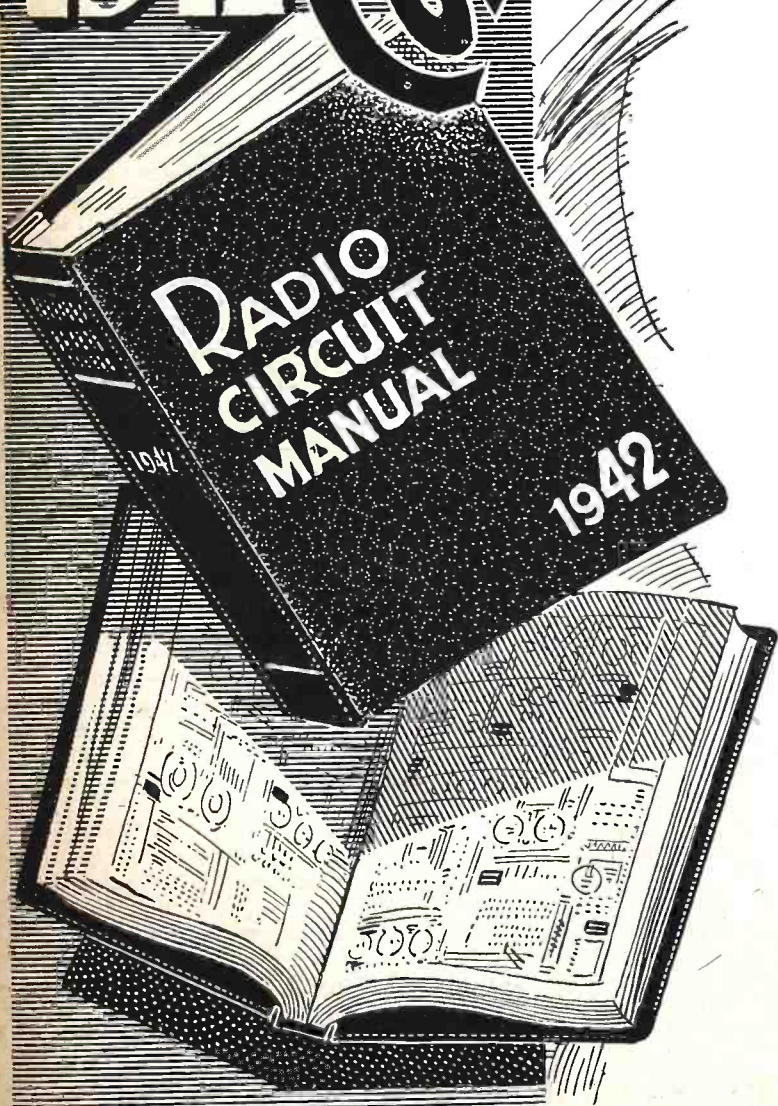

This Radio Circuit Manual has more listings than any other publication of its kind. Check for yourself on such makes as Lafayette, Emerson, Pilot, Philco, RCA, Stewart Warner. If time really means money to you then this **completeness** will save you many times the cost of the book. It is the greatest time-saver you can buy today.

No fumbling around! No turning over to another page! The big roomy pages of the Radio Circuit Manual contain everything on a single page. You will see not only schematics, but quick reference IF spot, parts lists, dial stringing, diagrams, tuning range and data, tube locations, voltage charts, trimmer locations, push button, set-ups, alignment notes and procedures, record changer details, etc.

THE ONLY EDITED MANUAL PUBLISHED!

The diagrams are perfect. Every one was checked and rechecked to make sure of it. The printing is clear and distinct. It's a pleasure to use this manual.

The index is another feature you'll like. At a glance you can tell whether a model is the same as another. No hunting back and forth . . . it's right there. Big readable type numbers and model numbers help to spot quickly what you want.

Special charts on tube and battery interchangeability, lights, ohms law, color codes; also a special article on "The Methods of Substitution" by F. L. Sprayberry, to make your war-time service job easier.

If you like your service manual in handy form—so shaped that you can grab hold of it easily and store in small space . . . if you like a book that lies open flat so you don't constantly lose the place . . . then you will certainly appreciate the Radio Circuit Manual.

LIMITED NUMBER OF 1941 MANUALS LEFT

Our 1941 RADIO CIRCUIT MANUAL—the first we ever issued—proved so popular that we cleared out most of them in a short time notwithstanding a large printing. However, during a recent inventory, we discovered a small number still on hand which we are disposing of quickly. This should be good news to anyone who failed to get the 1941 edition. After all, many 1941 models must be serviced today, and the 1942 edition won't help at all for the earlier models. The price of the 1941 edition is the same as 1942 . . . only \$10 each.

Everything relating to a model is on a single page. **Mighty Handy!**

700 fact-packed pages. The actual page size is 10 x 12 3/4 inches.

**\$10
EACH**

Use this simple coupon for ordering the 1941 and 1942 Radio Circuit manuals.



RADCRAFT PUBLICATIONS, INC.
25 West Broadway, New York 7, N. Y.

Gentlemen: Rush to me by return mail, the RADIO CIRCUIT MANUAL ordered below, which I understand is priced at \$10 each.

I enclose remittance to the amount of \$.....
 Kindly send C.O.D.

1941 Edition

1942 Edition

Name (PLEASE PRINT CLEARLY)

Address

City Dist. No., if any.....State.....
(If remittance is enclosed, send in form of check or money order; register your letter if you send cash)

ELECTRICITY

• for Radio and Electronic Applications

ONAN ELECTRIC GENERATING PLANTS supply reliable, economical electric service for electronics applications as well as for scores of general uses.

Driven by Onan-built, 4-cycle gasoline engines, these power units are of single-unit, compact design and sturdy construction. Suitable for mobile, stationary or emergency service.

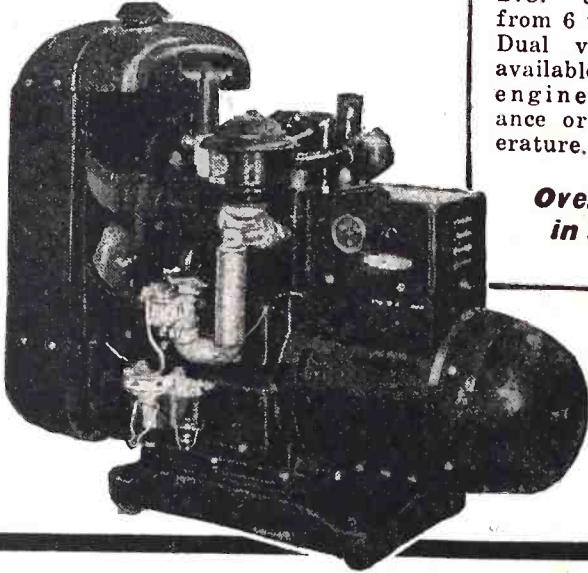

Models range from 350 to 35,000 watts. A.C. types from 115 to 660 volts; 50, 60, 180 cycles, single or three-phase; 400, 500, and 800 cycle, single phase; also special frequencies.

D.C. types range from 6 to 4000 volts. Dual voltage types available. Write for engineering assistance or detailed literature.

**Over 200,000
in service**

Model Shown is from W2C series, 2 and 3-KW, 60-cycle, 115 volt; powered by water-cooled, 2-cylinder engine.

D. W. ONAN & SONS 2410 Royalston Ave.,
Minneapolis 5, Minn.

She Tunes With Her Teeth

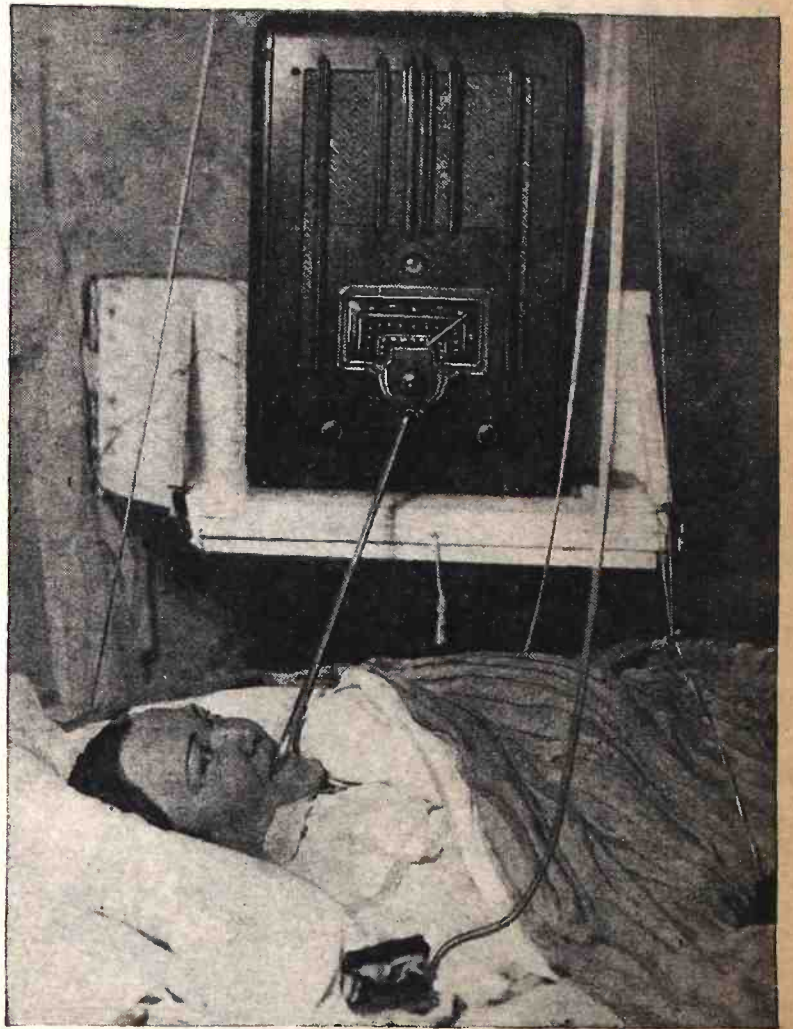

LEARN Electricity
In Shops of Coyne
"Learn by Doing" in 12 weeks, in big shops of Coyne—Not by correspondence. Earn while learning. Industrial Electronics, no extra cost. Free employment service after graduation. Ask for details of "Pay-After-Graduation" plan and free book.
COYNE ELECTRICAL SCHOOL Dept. 94-78,
500 South Paulina Street Chicago 12, Illinois

Guaranteed Rebuilt Radio VIBRATORS—\$1.00 ea.

Send old vibrator. For very prompt delivery, enclose remittance and return postage. We rebuild any make or kind of vibrator or relay. Vibrator packs rebuilt also. Send your old vibrator to
BEST VIBRATOR CO., Box 5802-Z, Cleveland 1, O.

Choose the CANNON BALL HEADSET
You Like Best



Scientifically Built
Heavy bar magnets greatly increase their efficiency.

Rugged construction. Inside or outside terminals. Sensitive. Clear tone. Dependable quality. Headset Headquarters guarantees satisfaction. Write for folder R-12.

C. F. CANNON COMPANY
SPRINGWATER, N. Y.

USED Correspondence Courses

NELSON CO., 321 So. Wabash Ave., Dept. 2-39, Chicago 4, Ill.

Complete HOME-STUDY Courses and self-instruction books, slightly used. Rented, sold, exchanged. All subjects. Satisfaction guaranteed. Cash paid for used courses. Full details & 92-page illustrated bargain catalog Free. Write now.

Deprived of the use of both hands and feet by infantile paralysis at the age of three, Thelma May of El Campo, Texas, refuses to let that handicap get in the way of a successful career. Dependent on her teeth to do most of the things other people need both hands for, she has not only carved out a moderately prosperous small business for herself, but is able to enjoy her radio when the day's work is done.

The receiver is placed on a shelf hinged to the wall, so that it can be swung out over the bed at night. Tuning is done with the stick, as shown. "Manipulating" the radio with the strings and the stick, Miss

May is able to draw it out into operating position, turn it on or off and tune in her favorite stations. Other strings operate the electric fan and lock or unlock the door. In the winter still another one turns an electric heater on or off. The irons serve as convenient weights.

Starting as salesman, Miss May is now the owner of a small mattress factory, and also operates a magazine subscription agency. As far as is known, radio is her favorite hobby, though she is also a movie-fan, and "was lucky enough," as she says, to win her present bedroom suite at a local picture show.

GRIDIRON RADIO INTERCOMMUNICATOR

With this newly-patented device the future football coach will be able to instruct his players in true military style. The helmet proper is shown at left, the ear protector being provided with an earphone. In the rear is an elongated pocket structure, to accommodate a portable short-wave receiver. For protection against shocks the pocket structure is constructed of heavy leather, with a light resilient lining, and a thick rubber sponge liner. Use of this instrument by the captain on the football field should do much to speed up the game by providing direct communication between him and the coach at all times.

SHORT WAVE RADIO RECEIVER IN POCKET



EAR PHONE IN HELMET

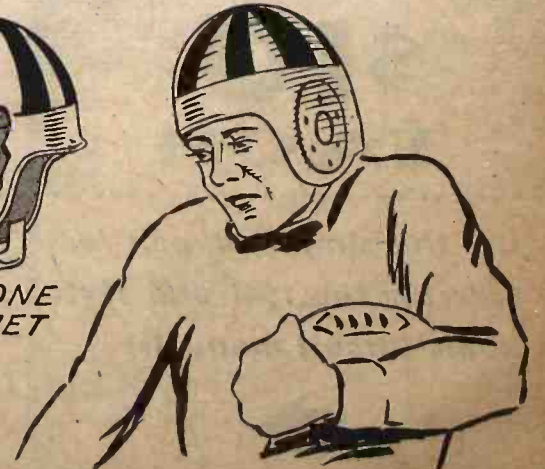

Swing into action for the



PLAN YOUR PLANT DRIVE NOW!

Good organization will be needed to sell the 6th. The task of raising the huge sum required will be the most difficult ever asked of Industry. As each new military success brings us closer to Victory, the public naturally will feel that the urgency of war financing is lessened—whereas it isn't. So organize now to prevent a letdown on the home-front from causing a letdown on the fighting front. Build your plant's payroll campaign around this fighting 8-Point Plan. You don't have to wait for the official Drive to start—swing into action NOW!

1 BOND COMMITTEE—Appoint a 6th War Loan Bond Committee from labor, management and each representative group of the firm.

2 TEAM CAPTAINS—Select a team captain, for each 10 workers, from men and women on the payroll—but not in a supervisory capacity. Returned veterans make most effective captains.

3 QUOTA—Set a quota for each department and each employee.

4 MEETING OF CAPTAINS—Give a powerful presentation of the importance of the work assigned to them. Instruct them in sales procedure. Have them carefully study the Treasury Booklet, *Getting the Order*.

5 ASSIGNMENTS—Assign responsibilities for:
(a) *Musical, speeches and announcements of the opening rally.*

(b) *Pre-drive letter to employees from management and labor.*

(c) *Competitive progress boards.*

(d) *Meeting schedules, etc.*

6 CARD FOR EACH WORKER—Dignify each personal approach with a pledge, order, or authorization card made out in the name of each worker. Provide for a cash purchase or installment pledge. Instruct each captain to put a pencil notation on the card to indicate the subscription he expects to solicit from each worker.

7 RESOLICITATION—People don't mind being asked to buy more than once. Resolicit each employee toward the end of the drive in a fast mop-up campaign. Call upon your State Payroll Chairman; he's ready with a fully detailed plan—NOW!

8 ADVERTISE THE DRIVE—Use all possible space in the regular media you employ to tell the War Bond story.

The Treasury Department acknowledges with appreciation the publication of this message by

RADIO-CRAFT

SLIDERULE

OR

SCREWDRIVER

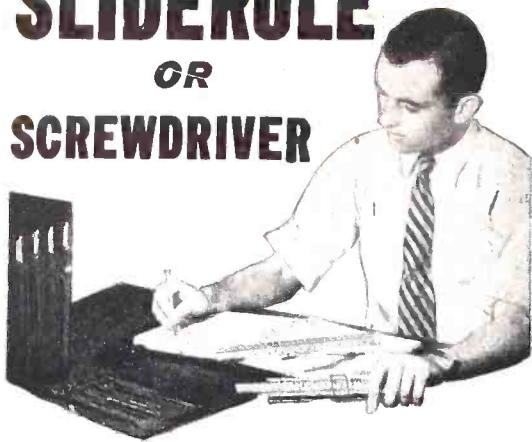

... which will YOU be using 2 years from now?

Add CREI Technical Training to Your Present Experience — Then Get That BETTER Radio Job You Want!

Thousands of new men have joined the ranks of the radio industry for the duration. But after the war, even more thousands will return from the armed forces. War production will settle down to supplying civilian needs. *Where will you fit into this picture?*

If you are wise, you will look ahead and prepare for the good-paying jobs in radio-electronics and industrial electronics. Every man in radio today has the opportunity to see the amazing developments that are taking place, as well as the unlimited opportunities available to men with modern technical training.

It is up to you to decide if you will be a "screwdriver" mechanic or a real technician in a responsible engineering position.

CREI can help you prepare by providing you with a proven program of home study training that will increase your technical ability and equip you to advance to the better-paying radio jobs that offer security and opportunity. The facts about CREI and what it can do for you are printed in a 36-page booklet. It is well worth your reading. Send for it today.

● WRITE FOR NEW, FREE 36-PAGE BOOKLET

If you have had professional or amateur radio experience and want to make more money—let us help you qualify for a better radio job. TELL US ABOUT YOURSELF, so we can intelligently plan a course best suited for your needs.—PLEASE STATE BRIEFLY YOUR BACKGROUND OF EXPERIENCE, EDUCATION AND PRESENT POSITION.



CAPITOL RADIO ENGINEERING INSTITUTE

Home Study Courses in Practical Radio-Electronics Engineering for Professional Self-Improvement

Dept. RC-12, 3224 — 16th Street, N. W.
WASHINGTON 10, D. C.

Contractors to U.S. Navy—U.S. Coast Guard—Canadian Broadcasting Corp.—Producers of Well-trained Technical Radiomen for Industry

SPEECH AMPLIFIER DESIGN

(Continued from page 154)

voltage appearing across it. This voltage has the effect of reducing the gain of the low frequencies. This unnecessary reduction of the bass notes may be prevented by employing a cathode by-pass condenser sufficiently large to have a very small reactance at the lowest frequencies to be amplified.

Those who have the occasion to build or use a high-gain amplifier will at some time run into internal feedback, which will be manifested in the form of uncontrolled oscillations and motorboating, caused by regeneration within the circuits. This problem is most common when a common plate voltage supply is used. The final stage of the amplifier will develop an alternating current voltage between the plate of the tube and the ground. From Fig. 2 we see that when the voltage is measured from the plate and ground, a portion of this voltage appears across the output of the power supply. The reason for this voltage drop is that the filter condensers of the power supply seldom have sufficient capacity to have negligible reactance. Therefore the alternating voltage will also appear across the plate supply of the other tubes in the amplifier. In each case when the alternating voltage is placed on the plate of a tube, it is transferred to the grid of the following stage. Thus internal feedback is generated within the amplifier. Perhaps a better understanding of this phenomenon will be gained from a study of Fig. 2.

Suppression of regeneration in the amplifier stages may be accomplished by inserting an additional resistor in series with the supply voltage and the plate loading resistor. A large-capacitance condenser is placed between the junction of the two resistors and the ground. The feedback voltage from the last audio stage will ap-

pear across the resistor which we have added to the circuit. This resistor is known as the decoupling resistor. The condenser serves two purposes. First, it by-passes the unwanted voltage to ground. Second, it serves to furnish additional filtering for the plate voltage of each stage, thus reducing residual hum which may be present due to insufficient filtering in the power supply. See Fig. 3.

The value of the decoupling resistor R_d may be determined from the equation

$$R_d = \frac{E_d}{I_p} \times 1,000$$

where

R_d = decoupling resistor, in ohms
 I_p = total plate current, in milliamperes
 E_d = maximum allowable voltage drop across R_d

When selecting the tube line-up for your speech amplifier, it is common to employ a pentode tube in the first stage, due to the very low input voltage which is often encountered there. It is seldom necessary to use two pentode stages in cascade because such high amplification concentrated in the first stages of an amplifier will often cause dynamic instability. Whenever using pentode tubes, care should be taken to see that the screen grid voltage is kept at the correct value. This voltage may best be obtained from a voltage divider across the power supply output. The screen should be sufficiently by-passed to keep it always at zero potential with respect to audio voltages.

It is well to bear in mind that the first two stages of a high gain amplifier should be completely shielded. The grid leads of these stages should, in addition be as short as possible. The time spent in careful workmanship will fully repay you for your efforts by giving trouble free operation.



British Combine Photo

On this ship, built in a Canadian yard, are young seamen who have been torpedoed twice since war began. With them are veterans from the days of sailing ships. During this voyage temperature dropped so low ship's water froze, hawsers became unmanageable because of ice-coating. In the radio-room, Operator Art Sim, bracing himself against the rolling of the ship.

World-Wide Station List

Edited by **ELMER R. FULLER**

A STRANGER is being heard on 18,430 megacycles and has been heard at various times from 11:55 am to 12:34 pm when they are usually signing off. The program when heard here was music with a girl singing and announcements being made by a man. There were no identifying announcements.

The QRM has been brought to mind on the frequencies used by the United States Bureau of Standards, particularly the 5 and

10 megacycle spots. Sometimes it is almost impossible to pull in WWV and then it is mixed up with other stations. It seems as though these spots could be reserved for this purpose.

It is hoped that by the time that you read this, the Listening Post Certificates will be in the mail and on their way to our observers. We could still use more reports, and any number of observers is not enough.

The more reports we have, the better chance we have of keeping the station list accurate and up-to-date. If you know of any corrections that should be made, let us know about them. This is the only way in which we can keep this station list in order and corrected. Send your correspondence to Elmer R. Fuller, c/o Radio-Craft, 25 West Broadway, New York City, 7.

Schedules below are Eastern War Time.

Mc.	Call	Location and Schedule	Mc.	Call	Location and Schedule	Mc.	Call	Location and Schedule
2.500	WWV	WASHINGTON, D. C.; U. S. Bureau of Standards; evenings only.	6.070	CFRX	TORONTO, CANADA; Sundays, 9 am to midnight; Monday to Friday, 7:30 am to 12:05 am; Saturday, 7:30 am to 12:45 am.	6.100	XGAW	JAPANESE CONTROLLED CHINA; 1 to 1:30 am irregular.
2.880	GRC	LONDON, ENGLAND; 10 pm to midnight.	6.080	CKFX	VANCOUVER, CANADA.	6.105	HJFB	MANIZALES, COLOMBIA.
3.450	YV7RB	CUMANA, VENEZUELA.	6.080	WLWK	CINCINNATI, OHIO; European beam, 12:15 to 2:30 am; West South America beam, 8:30 pm to midnight.	6.110	GSL	LONDON, ENGLAND; North American beam, 8 pm to 12:45 am.
3.500	YV5RX	CARACAS, VENEZUELA; sked not known.	6.090	CBFW	VERCHERES, CANADA; daily, 7:30 am to 11:30 pm.	6.120	WOOC	NEW YORK CITY; European beam, 9:30 pm to 3:30 am.
3.500	COCX	HAVANA, CUBA; heard evenings.	6.090	ZNS2	NASSAU, BAHAMAS.	6.12	XEUZ	MEXICO CITY, MEXICO; heard before midnight.
4.107	HCJB	QUITO, ECUADOR.	6.095	OAX4H	LIMA, PERU.	6.120	WCRC	NEW YORK CITY; European beam, 12:15 to 2:45 am.
4.700	ZQI	KINGSTON, JAMAICA; Sunday, 6:15 to 6:55 pm; daily, 6:15 to 7:15 pm.	6.098	ZRK	CAPETOWN, SOUTH AFRICA; heard at 10:30 pm.	6.120	LRXI	BUENOS AIRES, ARGENTINA.
4.75	YV1RV	MARACAIBO, VENEZUELA.	6.100	WNRA	NEW YORK CITY; European beam, 11:45 pm to 2 am.	6.130	JZH4	TOKYO, JAPAN; 11 am to 2:40 pm.
4.76	YV4RO	VALENCIA, VENEZUELA.	6.100	VPD2	SUVA, FIJI ISLANDS; 1 to 3 am.	6.130	COCD	HAVANA, CUBA.
4.765	HJFB	MANIZALES, COLOMBIA.	6.100	KROJ	LOS ANGELES, CALIFORNIA; Oriental beam, midnight to 3:45 am.	6.130	CHNX	HALIFAX, NOVA SCOTIA; Sundays, 8 am to 6:55 pm; Monday
4.77	YV1RY	CORO, VENEZUELA.						
4.785	HJAB	BARRANQUILLA, COLOMBIA; heard at 8:30 pm.						
4.79	YV6RU	BOLIVAR, VENEZUELA.						
4.830	YV2RN	SAN CRISTOBAL, VENEZUELA; heard at 8:30 pm.						
4.895	YDP3	SOERABAYA, NETHERLANDS INDIES; heard at 8:45 pm.						
4.92	YV5RN	CARACAS, VENEZUELA; late evenings and early am.						
4.965	HJAE	CARTAGENA, COLOMBIA; heard at 8:30 pm.						
4.99	YV3RN	BARQUISIMETO, VENEZUELA, heard evenings.						
5.000	WWV	WASHINGTON, D. C.; U. S. Bureau of Standards.						
5.000	HJCA	BOGOTA, COLOMBIA; evenings.						
5.145	PMY	BANDOENG, NETHERLANDS INDIES; heard at 8:45 pm.						
5.620	OAX2A	TRUJILLO, PERU.						
5.75	PZX	PARAMARIBO, DUTCH GUIANA.						
5.810	KRO	HONOLULU, HAWAII; news in English at 7:45 am.						
5.875	HRN	TEGUCIGALPA, HONDURAS.						
5.88	—	CAPETOWN, SOUTH AFRICA.						
5.935	PJCI	CURACAO, NETHERLANDS INDIES.						
5.900	LRSI	BUENOS AIRES, ARGENTINA.						
5.935	PJC2	WILLEMSTAD, CURACAO (NETHERLANDS WEST INDIES); Saturdays only, 12 to 12:45 am.						
5.980	VONH	ST. JOHN'S, NEWFOUNDLAND.						
5.985	XGOA	CHUNGKING, CHINA; 10 am to 1:45 pm.						
6.000	ZOY	ACCRA, GOLD COAST; 10 pm to 1 am.						
6.005	VE9AI	EDMONTON, CANADA; midnight to 2 am.						
6.005	HP5K	COLON, PANAMA; 8:30 to 9:30 pm.						
6.005	CFCX	MONTREAL, CANADA; Sunday, 7:30 am to midnight; Monday to Saturday, 6:45 am to midnight.						
6.007	ZRH	JOHANNESBURG, SOUTH AFRICA; midnight to 3 am except Saturdays.						
6.010	GRB	LONDON, ENGLAND.						
6.010	CJXC	SYDNEY, NOVA SCOTIA; Monday to Friday, 7 to 11 am; Saturday, 6:45 to 11 am; Sunday, 8 to 11 am.						
6.025	AFHQ	ALGIERS ALLIED RADIO.						
6.03	DXP	BERLIN, GERMANY; evenings; sometimes afternoons.						
6.04	COBF	HAVANA, CUBA.						
6.040	—	ALGIERS ALLIED RADIO; 4 to 6 pm daily.						
6.040	WRUW	BOSTON, MASS.; Central America beam, 9:30 pm to 2 am.						
6.05	GSA	LONDON, ENGLAND.						
6.060	WCBN	NEW YORK CITY; Mexican beam, 7:30 pm to 2 am.						
6.060	WCDA	NEW YORK CITY; European beam, 2:15 to 4 am.						
6.066	SBU	STOCKHOLM, SWEDEN; 2:30 to 5:15 pm.						

(Continued on page 192)

SMART IDEA:

Though we're all absorbed in vital war work, let's give some thought to the future. Do a smart thing now — get thoroughly acquainted with Insuline's vast line of Radio-Electronic Products and the Insuline Manufacturing Facilities... These 2 books tell the story. Write for them now.

48-page Catalogue describes Insuline's vast line of Radio-Electronic Products.



8-page Brochure presents Insuline's organization and manufacturing facilities.

What are your requirements? Send data for immediate assistance.

INSULINE

CORPORATION OF AMERICA

INSULINE BUILDING · LONG ISLAND CITY, N.Y.

HEADQUARTERS FOR RADIO-ELECTRONIC PRODUCTS





In writing advertiser, please mention RADIO-CRAFT

9 out of 10
BUSY RADIO
TECHNICIANS SAID

**"HERE'S THE WAY
 TO LEARN
 RADIO RIGHT!"**

GHIRARDI
TEACHES IT TO YOU
EASIER • BETTER • FASTER

724 OUT OF 817!

When you want the facts about something—go to the men who know! When you want to find out what is the best Radio-Electronic Training for YOU—ask Radio-Electronic men! That was exactly our idea when we went to a mixed group of 817 radio-electronic men—a group made up of instructors, students, repair men, radio-electronic experts in the armed forces and in big manufacturing plants. We asked them to tell us exactly what they think of various books and courses now being offered for the study of Radio-Electronic fundamentals. NINE OUT OF TEN of these men wrote back that Alfred A. Ghirardi's RADIO PHYSICS COURSE book is their choice as the best buy on the market—far better than any other book or course they have ever seen. And, as they explained—

HERE ARE THEIR REASONS WHY:

- 1 "It's simple, clear way of thoroughly explaining every detail makes it the most easily understood of all Radio-Electronic books and courses. Especially designed for beginners!"
- 2 "It teaches Radio-Electronic fundamentals more quickly and more interestingly than any other. No previous training required!"
- 3 "It gives the most complete coverage of Radio and Electronic subjects—all in one handy volume."
- 4 "It is the most inexpensive, complete basic training available—easily worth from \$50 to \$100 if you bought it as a course."

TRAIN AT HOME—In Spare Time

Ghirardi's RADIO PHYSICS COURSE is tried and tested. It gives MAXIMUM training in MINIMUM time and at an absolute MINIMUM cost. You learn at home in spare time. You progress as fast as you want to. Actually Ghirardi's RADIO PHYSICS COURSE gives you the scope of 36 different courses in one—all packed into an easy-to-follow 972-page book with 508 clear illustrations, and 856 self-testing review questions. You can understand every word of it without previous training—and you'll be pleasantly surprised how easily you'll master the subjects that other books and courses make seem very complicated. Our 5-day Money Back Guarantee enables you to examine this great book for five full days—and get every cent of your money back if you're not more than satisfied.

Let A. A. Ghirardi—Radio's most widely-read technical author—help you start your training for a fascinating, profitable, wartime or peacetime job in the vast new Radio-Electronics field.

MAIL THIS COUPON NOW!

RADIO & TECHNICAL DIVISION
Murray Hill Books, Inc.

Dept. RC-124, 232 Madison Ave., New York 16, N. Y.

Rush me a copy of your big, 972-page RADIO PHYSICS COURSE BOOK. I am enclosing \$5. (\$5.50 foreign.)

Send C.O.D. (in U.S.A. only) for \$5 plus postage.

In either case, I may return the book within 5 days for refund if I am not completely satisfied with it.

Name

Address

City (and Dist. No.) State

COMPLETE BASIC RADIO-ELECTRONIC TRAINING IN ONE BIG VOLUME

ONLY \$5
Complete

(Postpaid in the U.S.A.)

Easily worth \$50 if you bought it as a course

NO OTHER COURSE LIKE IT

There is no substitute for Ghirardi's RADIO PHYSICS COURSE—simply because there isn't any other book or course like it at any price. That's FACT—not fiction—and backed up by PROOF, not mere claims!

M. J. Turim of Brooklyn, N. Y., says: "I've read many Radio books but have failed to find a more detailed, thorough, and easy-to-understand book than Ghirardi's Radio Physics Course. It's the best course on the subject available today—ABSOLUTELY UNBEATABLE."

J. R. Robertson, Jr., of Bessmer, Ala., says: "As simplified, complete and understandable a Radio-Electronic Training Course as I have ever seen AT ANY PRICE."

ELECTRONICS, TOO!

And don't forget, RADIO PHYSICS COURSE does not end at teaching you only Radio! The basic instruction you get from this big book is your introduction to the vast, rapidly growing field of Electronics, too. It is your "Open Sesame!" to more money and a better job in this amazing new industry you've been reading so much about.

Order your copy today. SEE it. EXAMINE it for yourself. Here is our GUARANTEE:

YOUR MONEY BACK IN 5 DAYS
 If Ghirardi's Big 972-page RADIO PHYSICS COURSE doesn't teach you RADIO-ELECTRONIC fundamentals EASIER, FASTER, and at LESS COST than any other book or course.
YOU BE THE JUDGE!

INDUSTRIAL ELECTRONICS

(Continued from page 153)

be vibration tested, it is mounted in its crankcase. One end of the shaft carries a heavy flywheel while the opposite end is coupled to an electric motor, but through a special equipment which converts the amplified audio to an alternating advancing and retarding force which varies the shaft's irregular velocity at any specific frequency within wide limits of power applications.

The drive shaft carries an electrostatic pickup device which provides a direct reading of the degree of torsion. When properly employed, this equipment will provide the natural vibration period of any shaft tested. It has supplied many invaluable design data in connection with crankshafts.

Many other high speed machinery parts are tested by means of electronic equipment. Motor and generator armatures and turbine rotors are now being checked very quickly by means of quick vibration measurement.

Fig. 6 shows a simplified diagram of the procedure used in the turbine department of the General Electric Co. A vibration motor is operated against the turbine rotor when it is at rest and a vibration detector contacts the periphery of the rotor through the medium of a rotor while the former is in motion. A permanent record of the performance is made.

In the testing procedure, the vibrating force is applied to the turbine while it is motionless. As the frequency is varied over a wide range, the amplitude of the wheel varies and this is naturally increased to a very high value whenever the basic frequency of the vibrator force or its harmonics coincide with one of the many resonant frequencies of the turbine wheel.

The vibration motor is energized by a 1000 volt-ampere amplifier driven by an oscillator of variable frequency.

Vibration amplitude is detected by means of a crystal and its associated equipment comprises an amplifier, cathode ray oscillograph and a photoelectric recorder.

In all probability hundreds of ingenious applications of electronics remain unknown to the engineering fraternity at large for the simple reason that many manufacturers who use such devices—feeling that competition would take undue advantage of their disclosures—have not publicized their work.

One rarely hears of explosion-proof photoelectric equipment for automatic adjustment of carburetors through a manometer tube. There is also an electronic dwell timer for controlling presses during the full pressure part of the stroke. Excellent photoelectric monitoring has been developed and is in use for feeding powdered fuel to boilers. Phototubes have also been successfully employed in the control of special valve grinding machines used in the automobile industry. This industry is known to have made a large number of special photoelectric devices. It is also known that not all of these devices have been publicized.

The photoelectric tube has also become very popular during the war in certain inspection jobs, relating not only to tolerance in reference to sizes but in the condition and color of surfaces as well. Shadow tolerance gages have also been devised in which an enlarged silhouette of an object is cast on a special screen.

One can only guess at the large number of secret applications of electronics that have been made during the war. Clearly many new and startling revelations will be made after hostilities cease.

FM WINS ON ALL FRONTS

PRAISE for FM's role in the war continues to pour from the Signal Corps whose chief, Major General Harry C. Ingles, last Saturday presented Major Edwin H. Armstrong, FM inventor, with the first of his Certificates of Appreciation, an award rating with the Army-Navy "E."

Through the courtesy of the *Frequency Modulation Bulletin* we print a list of FM radio receivers and transmitters on which the War Department has permitted these details to be published. Other FM apparatus, still on the restricted list, may also be in use.

The Signal Corps obtained special permission from the War Department for FMBI to publish certain detailed information on some of its FM equipment. Among the FM sets used by the Signal Corps are:

1. SCR-508—A short range, vehicular FM set. Armored Force Command set. Has integral interphone amplifier. Principal components: 1 transmitter, 2 receivers, 1 mounting base, 1 vehicle antenna. Transportation: vehicle.

2. SCR-509—A light weight, short range FM set. Principal components: radio receiver and transmitter. Transportation: man on foot or in any vehicle.

3. SCR-510—The same as SCR-509 except for the addition of vehicular components. Short range frequency modulated vehicular or ground radio set. May also be used as short range Mobile Command set. Principal components: receiver and transmitter; plate supply unit. Transported and operated in vehicle or carried by man on foot.

4. SCR-528—Vehicular, short range, FM transmitter and receiver. Principal components: integral interphone transmitter; receiver; mounting. Transportation and operation in vehicles.

5. SCR-538—Comprises one receiver and a separate interphone amplifier. Same mounting base is used as for SCR-508 and 528, permitting use of the components of any of these sets. Principal components: receiver; interphone amplifier; mounting; mast base. Transported and operated in vehicles.

6. SCR-608—Vehicular set for operation by non-radio specialist. Permits communication with the Armored Force. Remote control. Principal components: radio transmitter; radio receiver; mounting; remote control unit. Transportation: vehicles.

7. SCR-609—A portable set capable of being carried in any vehicle of the Field Artillery. Radio Sets SCR-609 and SCR-610 are the same except for power supply. SCR-609 uses batteries. SCR-610 is equipped with a power supply to operate from vehicular battery as well as self-contained battery supply. Principal components: receiver and transmitter; case for batteries; remote control unit. Transportation: Vehicle or man pack.

8. SCR-610—A portable set, capable of being carried in vehicle of Field Artillery, also portable as one-man load. Operation does not require radio specialists. Remote controlled. Principal components: receiver and transmitter; plate supply unit; mounting; remote control unit; case for batteries. Transported and operated in vehicle or carried by man on foot.

9. SCR-628—For operation on voice by persons who are not radio specialists. Principal components: transmitter; receiver; mounting; antenna mast base; remote control unit. Transported and operated in vehicles.

10. SCR-300—Walkie-Talkie described in *Radio-Craft*, December, 1943.

These 2 GHIRARDI BOOKS

Will help you to Diagnose, Locate and Repair Receiver Troubles

EASIER • BETTER and FASTER



ALFRED A. GHIRARDI

—the man who makes Radio easy to learn

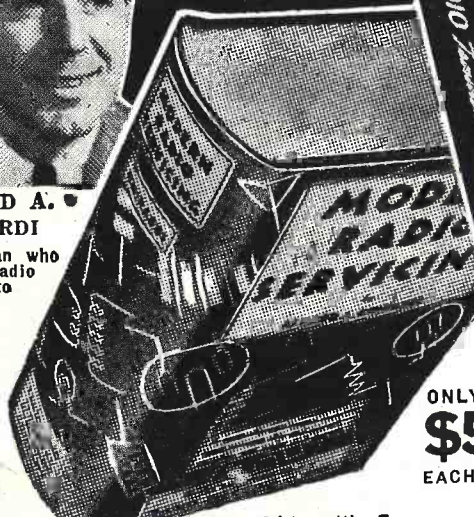

ONLY \$5 EACH!

Ghirardi's Famous

MODERN RADIO SERVICING

The book that trains you quickly to MAKE MORE MONEY and get a bigger job as a Radio-Electronic repair technician BECAUSE it is by far the largest, finest, most easily understood how-to-do it training course on the subject!

"Modern Radio Servicing" is the only single, inexpensive book that gives you a thorough training in the construction and working of all types of test instruments; receiver troubleshooting procedure; circuit analysis; testing, repair, and replacement of individual receiver parts; installation; adjustments, maintenance; service shop management, etc.

No other book can compare with this one for complete, easily understandable instruction on every phase of service work. "I recently finished a course in Radio Repair at one of the N. Y. radio schools and all my learning at this school did not help me to understand and repair radios as quickly as did this one book. I made my money back on one job alone!" writes Henry Miller of Brooklyn, N. Y.

Test Instruments—Troubleshooting—Repair

You, too, can get a thorough and practical working training in Radio-Electronic servicing from this famous Ghirardi book —by yourself, in spare time at home—just as Mr. Miller and thousands of others have done. Its 1300 pages and 706 illustrations help you visualize every action. The 720 self-testing review questions help you check your progress. Progress as fast as you want to. It's the biggest servicing training bargain you can buy anywhere. You are protected completely by our

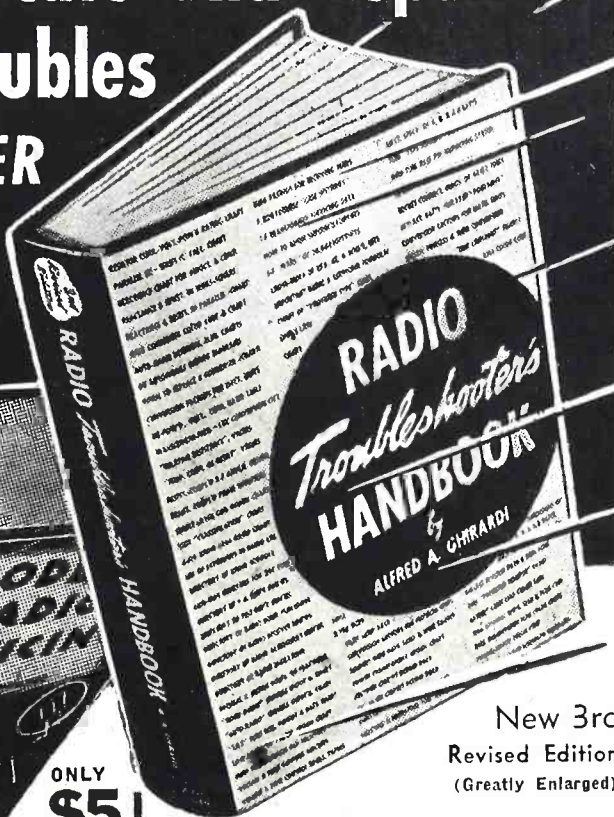

New 3rd Revised Edition (Greatly Enlarged)

RADIO TROUBLESHOOTER'S HANDBOOK

744 big pages, chock-full of just the kind of time-saving, money-making, tabulated and charted servicing data that servicemen are finding invaluable.

HERE'S HOW TO TEST A RADIO IN 2 MINUTES or less!

Ghirardi's RADIO TROUBLESHOOTER'S HANDBOOK isn't a "study book." It's an on-the-job data book to be referred to in your everyday work. For example, don't waste your time on complicated troubleshooting for every ailing receiver you are called upon to repair! First, look up its model number in the big Trouble Case History Section of the Handbook which lists common troubles and their remedies for over 4,800 models of receivers and record changers.

MAKE MORE MONEY!

Nine times out of ten the Handbook will give you the exact clue you need to repair a receiver at once—often without any testing at all! Similarly, on tubes, parts, replacements, substitutions, color codes, circuit alignment, auto radio, batteries, vibrators, ballasts, grid bias resistors, condensers, transformers, tone controls, filters, etc., etc., you get pages of quick-find, tabulated data to help do every repair job better—AND A LOT FASTER! This big new Handbook that weighs over 4 pounds is yours to use every day to make more money for only \$5 complete (\$5.50 foreign) and our Money Back Guarantee protects you. Order today!

5-DAY MONEY-BACK GUARANTEE

MAIL THIS COUPON NOW!

RADIO & TECHNICAL DIV. of Murray Hill Books, Inc., Dept. RC-124, 232 Madison Ave., New York 16, N. Y.

Enclosed find \$..... for books checked or send C.O.D. for this amount plus postage (sent C.O.D. in U.S.A. only). If not fully satisfactory, I may return books within 5 days and receive my money back.

- Special MONEY-SAVING COMBINATION — Both books \$9.50 (\$10.50 foreign).
 RADIO TROUBLESHOOTER'S HANDBOOK, \$5. (\$5.50 foreign).
 MODERN RADIO SERVICING, \$5. (\$5.50 foreign).

Name

Address

City (and Dist. No.) State

SPECIAL MONEY-SAVING COMBINATION OFFER!

Both books for only \$9.50 (\$10.50 foreign)

A total of OVER 2,000 PAGES of the world's most helpful and profitable servicing information!

REPAIR ANY KIND OF RADIO EQUIPMENT
PREPARE FOR A BETTER JOB AS A RADIO-ELECTRONIC TECHNICIAN

PORTABLE POWER PROBLEMS

THIS MONTH—G-E MODEL "B" ELECTROCARDIOGRAPH



HIGH SENSITIVITY and standardized operation characterizes the General Electric Model "B" Electrocardiograph which assists doctors in quickly establishing accurate diagnosis and prognosis of heart conditions. A true photographic record of minute changes in heart potential waves is given by this remarkable light-weight, *battery-powered* instrument. As a result, it quickly and economically makes available information that would otherwise be very difficult to obtain.

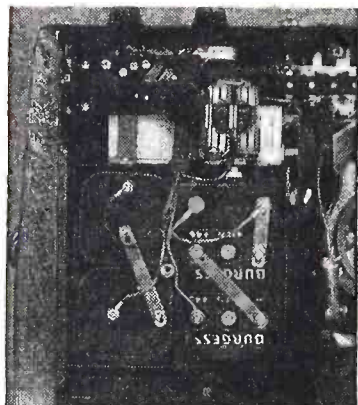

BATTERY COMPARTMENT houses the power heart of the G-E Model "B" Electrocardiograph (*Burgess "A" and "B" batteries are standard equipment.*) General Electric descriptive literature emphasizes that "*batteries provide the most dependable source of power — always smooth.*" Battery power assures operation anywhere — independent of commercial electric supply. Burgess engineers are constantly adapting special-purpose batteries for special commercial and industrial requirements. Let them solve *your* portable power problems.

Free 80-page Engineering Manual. 25 charts, 36 data tables and 31 descriptive pages on characteristics of dry batteries. Tabbed for ready reference. Write Dept. C-4 for free copy. *Burgess Battery Co., Freeport, Illinois.*



BURGESS BATTERIES

FADA
Permanent
NEEDLES

List \$1.00



Special Introductory Offer 39¢
(TO DEALERS ONLY—IN LOTS OF 6 OR OVER)

- Plays 4M Records without changing
- Better Tone Reproduction
- Help Reduce Background Hiss
- Longer Record Life

FADA OF NEW YORK
928 BROADWAY NEW YORK 10, N. Y.
Large Stock of Replacement Parts and Cabinets

11-TUBE SUPERHETERODYNE

(Continued from page 156)

plication at the I.F. threshold.

And that brings us to the double-diode, 6H6. The tie-in here is on a share-the-work basis. Each diode specializes. The first diode-cathode does the detecting. The second diode-cathode does the A.V.C. and indicator-tube biasing.

You will notice that the connections are identical with delayed A.V.C. circuit, except there is no delay voltage. The return is to cathode potential. Now if we substitute a diode-pentode here—a 6SQ7, says—we should have a delay represented roughly by the cathode bias on such tube, But I HAD a 6H6 and do not care for delayed A.V.C. with remote cut-off tubes.

This arrangement reduces diode shunting

and cuts down diode distortion by about 20%. This is no trifle, because 6V6's are in the power stage, and they have enough distortion of their own. This arrangement also permits attaching the grid of the 6C5 direct to the A.V.C. line.

The first audio stage is occupied by a 6C5. If we were using a diode-pentode in the second detector stage, we should not need the 6C5 at all, but feed the output directly into the phase inverter. If we replace the 6N7 with a 6SC7, we could use a 6R7 for a second detector and leave out the extra 6C5. But in either case we should have to worry about motor-boating, which is a weakness of high-gain high- μ amplifiers. So I used the 6C5.

The phase inversion method used is old-fashioned, but this is not so tricky as either the paraphase system or the balanced cathode-bias method. This set needs no inverse feedback, as both diode and harmonic distortion has been reduced to a negligible value by other means: by isolation of A.V.C. and tuning eye from the detector diode-cathode, and by that shunt filter from plate to plate of the 6V6's.

The push-pull output is conventional except for the tone balance filter mentioned earlier. Its impedance is 180 degrees out of phase with the impedance of the output secondary, and if calculated properly, will provide a level tone response, speaking in terms of volume, from 400 cycles to 10,000 cycles, with little variation on lower or higher audio frequencies.

It performs this miracle with no diminution in the volume impressed on the voice coil, as happens with inverse feedback, and serves as an automatic tone control. It acts as an absorptive filter on over-modulation, smoothing it out and feeding it back to the output. The effect is very much the same as that of inverse feedback on distortion, and as a well-regulated manually operated tone control on tone balance.

The filter is made by taking a wire-wound resistor of large enough dissipation value— $1\frac{1}{2}$ times the watt-output rating of one tube will do—of a resistance value equal to 1.3 times the plate resistance of the output. Connect this resistor by soldering to a .05 Mfd. condenser with ample voltage margin—say, 600-volt working voltage. If there is push-pull or phase-inversion output, solder the open ends of the filter to the plate terminals of the two tubes. If there is one tube in the output, connect the filter between plate and screen terminals of the tube—in other words, connect the filter directly across the primary of the speaker transformer.

I used choke input in the power pack for two reasons. I had come by two chokes intended for small transmitter use capable of doing the job, and I had acquired a Hi-Fidelity P.M. 12-in. speaker which had been stored away for several years. The second reason was that I like the voltage regulation choke input gives, in spite of the 75-volt drop, which is about what the average speaker field gives you, and with the transformer and speaker I had, I needed the drop to get the voltage down to a usable value.

All amplifier plate voltages are the same—250 measured at the socket. The oscillator plate voltage may range from 75 to 87 unless you have a special transformer. This voltage, in any event, must be taken off through a separate filter. Likewise the voltage for terminal 4 on the convertor (Hx. G2-G4). The voltage here should be 100.

Other screen voltages are 100 except in the output. Here the screens take 250 direct from the power potential, while the plates get the same less the drop in the output transformer primary.

AUTOMATIC CHANGERS

(Continued from page 152)

as the "Needle Landing Place." This action is generally accomplished by an adjustable stop lever which is placed in the way of the arm activating the pickup in order to limit the motion of its trip toward the record. The stop level comes into position just before the arrival of the pickup arm at the record and is retracted as soon as the pickup is lowered to the surface. The pickup is thereafter free to follow the record grooves until it reaches the eccentric groove again.

Since it is necessary for all phonograph mechanisms to accommodate both 10-inch and 12-inch records, a manual push button is usually provided to place one of two available stops into operating position or, in some cases, to vary the lever's length by sliding the fulcrum's position. Either method changes the needle landing-place, but in the latter case adjustments of the 12-inch position may be dependent on previous adjustments made on the 10-inch position or vice versa. This must be borne in mind when attempting to make service adjustments on any machine. Refer to service data on the particular type being adjusted and follow the exact procedure described or it may be difficult to make one adjustment without throwing the other one off.

Since, on most record changers, it is necessary to press a button in order to change the needle landing place, it is apparent that, although they can accommodate a stack of 10-inch records or a stack of 12-inch records, they cannot play through a stack of 10-inch and 12-inch records mixed unless there is someone present to push the button when a record of different size comes into playing position. This necessity would nullify the automatic feature when mixed records were to be played.

A record changer designed to handle mixed records is ordinarily arranged so that the push button may be set for 10-inch records. Then, whenever a 12-inch record is released, the needle landing place adjustment changes temporarily to its position for playing a 12-inch record, returning to the 10-inch position as soon as the "change cycle" is completed. If the succeeding record is of the 10-inch size the adjustment will then be correct. If the succeeding record is of the 12-inch size, the adjustment will again execute the temporary change-over. The operation is shown in Fig. 6:

A. The arm *a* effects the temporary changeover of the needle landing place. It is not disturbed by a 10-inch record.

B. A 12-inch record extends farther off the side of the turntable and, when it is released, strikes the arm, *a*, which causes the adjustment lever to be activated.

C. As soon as the needle has engaged the record groove, the arm is reset to its original position by the main cam wheel.

Due to the fact that the previous diagrams were, for the most part, theoretical and did not represent any particular make of machine, a representative type of record changer is shown in this article. The parts are labelled to correspond with the elements described in this paper.

CORRECTION

An error in the diagram of the "Four-In-Two" receiver, printed on page 616 of the July issue, resulted in transposing the cathodes of the 25A7. The rectifier cathode should properly go to pin 1 and the pentode cathode to pin 8.

NOW WESTON MODEL 785 INDUSTRIAL CIRCUIT TESTER!

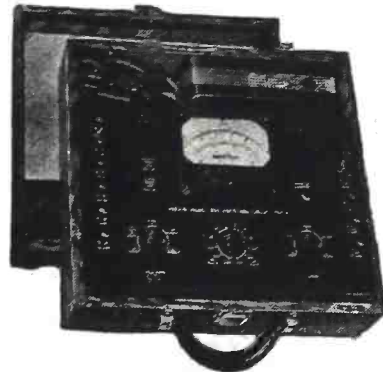

Tests Insulation and Cable Covering Resistance Values as Well!

With this new, compact unit which fits into the spare compartment and connects into the ohmmeter circuit with a pair of leads, Model 785 now provides for resistance measurements up to a value of 900 megohms. Thus the broad range coverage of this versatile maintenance tool now is as follows:

DC VOLTAGE . . . 0-1/10/50/200/500/1000 volts—20,000 ohms per volt. (*5000 volt range with external multiplier.)

AC VOLTAGE . . . 0-5/15/30/150/300/750 volts—1000 ohms per volt.

DC CURRENT . . . 0-50 microamperes, 1/10/100 milliamperes, 1 ampere and

10 amperes (*ranges above 10 amperes with external shunts).

AC CURRENT . . . self-contained ranges 0-.5/1/5/10 amperes (*higher ranges with an external current transformer).

RESISTANCE . . . 0-3000, 0-30,000, 0-300,000 ohms, 0-3 megohms, 0 to 30 megohms (self-contained batteries). 0-900 megohms (*with compact Model 792 Resistance Tester shown in illustration).

*Extra equipment on special order.

For complete facts on Model 785 write Weston Electrical Instrument Corp., 599 Frelinghuysen Ave., Newark, N. J.

WESTON Instruments

HALLICRAFTERS ★ HALLICRAFTERS



COMPLETE STOCKS

I have in stock NC-200s \$174.50 complete and some Hallicrafters receivers available for immediate delivery on priority and the following parts without priority: meter rectifiers \$1.95, transmitting tubes, transformers, resistors, condensers, panels, chassis, etc. Your orders and inquiries invited.

RECEIVER HEADQUARTERS for the Nation

BEFORE the war Bob Henry served the amateurs as the world's largest distributor of communications receivers.

Now Henry Radio is Hallicrafters receiver headquarters for the Nation at war. Hallicrafters Receivers can be supplied on AA-1 priority. I can usually supply SX-28s at \$223.00, SX-25s at \$94.50, and PM-23 speakers at \$15.00 at once. It takes longer to supply other models.

Soon, it is hoped, non-priority orders can be filled and Bob Henry can become again Hallicrafters headquarters for the nation at peace.

I have stores at Butler, Missouri, and at 2335 Westwood Blvd., Los Angeles 25, Calif.

Your orders and inquiries are invited.

Bob Henry, W9ARA
HENRY RADIO SHOPS

Butler, Mo. and Los Angeles, 25, Calif.

"WORLD'S LARGEST DISTRIBUTOR OF COMMUNICATIONS RECEIVERS"



WHAT'S YOUR IDEA OF THE
IDEAL POST-WAR RADIO &
TELEVISION SERVICE
BENCH

Write Today—Now!
\$100 in WAR BONDS
Given For **BEST LETTERS!**

★ First Prize, a \$50 Bond.
Second and Third Prizes
each a \$25 Bond.

Contest Ends
December 31, 1944.

★ **THINK OF IT—**

You can win a War Bond just by putting down your ideas as to what the ideal post-war Radio Service Bench should be. How many and what type of testing instruments for use on Radio, F-M, Television and so forth. How it must be arranged to render more efficient service—confidence. Your Ideal Service Bench.

★ **ANYONE CAN WIN—**

You can win. We want opinions from everyone interested in Radio and Television Service—Old Timers—Beginners. Experience will help—new-comers with good ideas can win.

★ **ENTER NOW!**

Remember, it is your opinion that wins, not literary ability.

It's Easy to Enter and the Rules Are Simple! Get That Letter Off to Us Today!

↓
RULES OF THE CONTEST

1. Simply write a letter (500 words or less) on the subject: "My Idea of the Ideal Post-War Radio and Television Service Bench."
2. Contest is open to all readers of Radio Craft (excepting employees of Burlingame Associates, their relatives, or their Advertising Agency).
3. You need not own a Radio Shop or possess any of the equipment you describe.
4. No detailed technical description of the apparatus is required or desired, nor the names of the manufacturers.
5. Mention of elaborate testing equipment suitable only for exhibition use will detract from the value of the letter. The inclusion of useful, confidence-creating apparatus, however, is recommended.
6. Literary ability is not required. Anyone writing in understandable English, giving a good word description, has an equal opportunity of winning one of the prizes.
7. Write only on one side; sign your name and address CLEARLY in the upper-right-hand corner; number each sheet.
8. No letters will be returned. Letters, contents and the ideas contained therein become the property of Burlingame Associates.
9. Judges' decisions will be final and duplicate prizes awarded in case of ties.

SEND ALL ENTRIES TO
BURLINGAME ASSOCIATES

10 MURRAY STREET—NEW YORK 7, N. Y.

EMERGENCY RADIOS (Continued from page 146)

plates are left. Both rotor and stator must be insulated from the panel and chassis. There must also be an insulated coupling between the rotor shaft and the dial. The coil should be soldered directly to the condenser terminals, and the tube socket mounted so that the connections from the plate and the grid to the coil are as short as possible. Grid condenser and grid leaks should be soldered to the socket terminal, and the RF choke and antenna connection directly to the grid end of the coil. The coil itself should be four turns of No. 14 wire, 1/2 inch in diameter, self supporting, with spacing adjusted to cover the 2 1/2 meter band.

The most satisfactory antenna is the telescopic auto-radio variety—extensible to at least four feet. This should be mounted on one or two feed-through insulators, preferably so that it may be readily detachable for transportation.

Batteries required are 90 or 135 volt "B," 1 1/2 volt "A," and 4 1/2 volt microphone. Since batteries available today are likely to be of a variety of sizes and shapes, the battery compartment should afford ample room to contain whatever types may be available.

To check for receiving, set the antenna condenser at low capacity, then advance the regeneration control until the characteristic "rush" noise is heard. Either squeeze together or spread apart the turns of the coil until the 2 1/2 meter band is located. The final adjustment consists of experimentally changing the antenna length and the antenna condenser setting. When switched to transmit, the frequency will be somewhat higher than in the receiving position. This is due to the change in plate voltage and to the grid leak. Thus if you are working on a spot frequency, it is necessary to adjust the frequency a little lower when transmitting. It is especially necessary to keep this in mind when two transceivers are working together; unless the frequency is carefully watched, it will increase step by step with each transmission.

The photos show several walkie-talkies used in WERS operation, as well as a

handy-talkie, which is simply a compressed version of the walkie-talkie, using miniature tubes, batteries, transformers, etc., and with the microphone and receiver mounted on the case.

Little sets like the one above have rendered very real service in more than one community during recent storms and floods. New York's opportunity came on the night of the recent hurricane. Alerted by the city's broadcast station, WNYC, two members of the War Emergency Radio Service picked their way carefully through Brooklyn streets in an automobile. They were en route to Coney Island, there to take up the task of establishing radio communications between police precincts, fire stations and hospitals after normal communication facilities had been temporarily disrupted by the storm. Approaching a major intersection, the car pulled up sharply. Not a dozen feet away the occupants spotted something rising out of a flooded area. Close inspection revealed the encumbrance to be a length of high voltage cable which had been torn loose from its pole.

The situation sized up, they flashed a warning from the short-wave transmitter built into their car. The message was picked up by a WERS volunteer in the area's police precinct headquarters, and a few minutes later an emergency crew was at the scene to remove the death-dealing wire. Witnessing the operation, one of the operators sighed with relief. "If a car didn't see that wire and hit it," he said, "the occupants would have looked like a burnt piece of toast."

Several of the 117 radio operators on hurricane duty narrowly averted possible serious injury this night. One operator had a close call when a tree and a high voltage cable fell across his automobile, but he luckily escaped bodily harm and damage to the vehicle was slight.

In spite of the dangers that lurked around them, the WERS operators remained on duty throughout the night, patrolling wide areas in different sections of the City until normal communications were restored shortly before dawn. All key men had been alert-



Suggested by Ed Marles, Chilliwack, B. C., Canada

"They say they'll release me for a 35L6."

ed at 2:00 P.M. on the day of the hurricane and some radio nets were not signed off by the City Control Station until after 3.00 A. M. the following morning. During this time, more than one thousand messages were handled, the majority police calls.

Mayor LaGuardia praised the WERS for its service to the city in one of his weekly radio broadcasts to the people of New York. He thanked the members of all of the protective forces for their assistance, and continued: "I must not forget the War Emergency Radio Service.

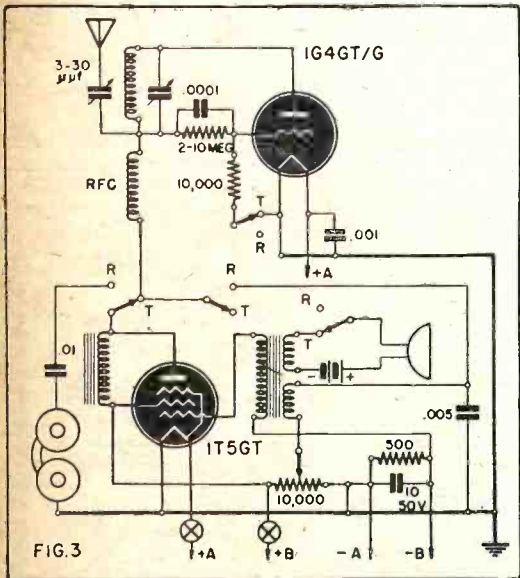

Complete circuit with switching arrangement.

You don't hear much about them. They are volunteers who have their own equipment, their own short-wave radios and their own cars. They turn out and furnish a very useful service. In this instance, they established communications where communications were discontinued. Again I want to thank the War Emergency Radio Service for the fine job they did."

WERS members were again pressed into action on September 24, but this time their services were "in fun," when a series of incidents were staged in connection with the organization's second anniversary. More than four hundred men and women took part in the drill, which consisted of an "emergency" in each of the five boroughs.

In one of the simulated incidents, Acting Captain Robert S. Purcell, assigned to the Air Warden Service headquarters, was picked up at his home, 1672 Second Street, Brooklyn, in four minutes after borough headquarters received the order from City Control Center.

Radio communication over the control center's transmitter was set up in two minutes between Presbyterian Medical Center and Bellevue Hospital in Manhattan so that the latter might rush blood plasma and other supplies to the medical center.

The Staten Island assignment took only eight minutes. Two mobile units and one walkie-talkie were sent to a "fire" at Bay and Prospect Streets, Stapleton, a distance of two miles.

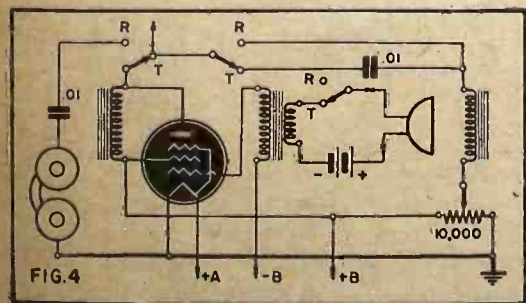

A simpler circuit using impedance coupling.

HERE'S THE POPULAR G-E UNIMETER

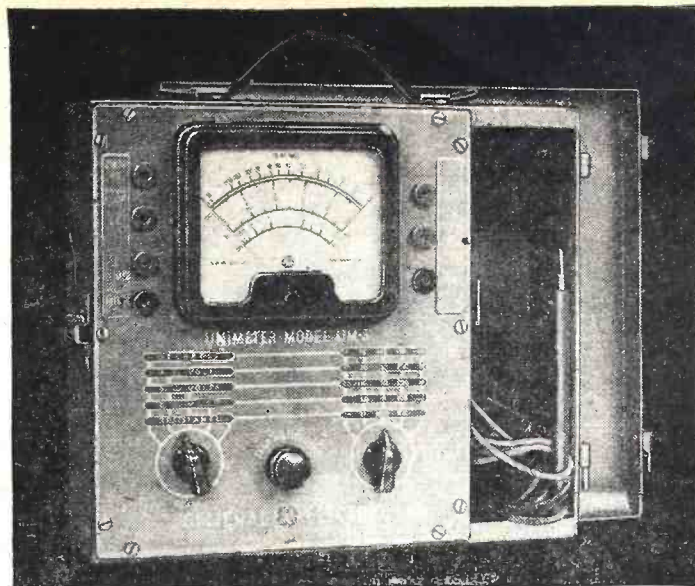

LIKE so many servicemen, you'll want to work with this completely portable all-around utility instrument. Large meter calibrated and protected by unique switching arrangement. Reduces error possibility, easy to read.

Other G-E units available for testing electronic circuits and component parts are: audio oscillators, oscilloscopes, condenser resistance bridges, signal generators and other utility test instruments.

It's a new G-E line—developed by G-E engineers—to help you do a better service job. *Electronics Dept., General Electric Co., Schenectady, N. Y.*

GENERAL ELECTRIC
164-C7
ELECTRONIC MEASURING INSTRUMENTS

NOW AVAILABLE*

Solar CAPACITOR ANALYZERS

PROMPT DELIVERIES!

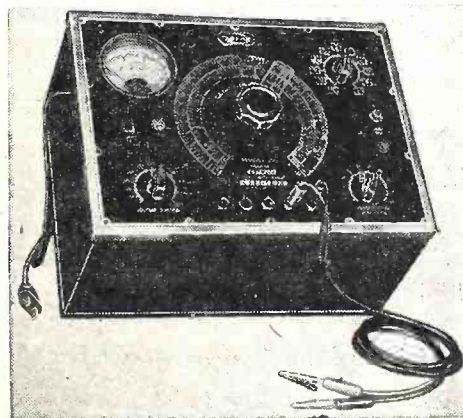

Illustrated Above: Model CE

- **MODEL CE-160** Capacitor Analyzer, for use on 110 volts A.C., 60 cycles. Dealer Net Price \$44.90 . . . FEATURES: With set operating or "dead," it shows shorts, open capacitors, R.F. impedance. Reveals intermittent shorts and opens. Measures capacity from .00001 mfd. to 2000 mfd. in four ranges. Measures resistance from 50 ohms to 10,000 megohms in five ranges. Also shows leakage, insulation resistance, and power factor of electrolytics. Many additional exceptional features of great value. Unit weight approx. 12 lbs.
- **MODEL CC-1-60** Capacitor Analyzer, for use on 110 volts A.C., 60 cycles. Dealer Net Price \$32.50 . . . FEATURES: Measures capacity, range .00001 to 800 mfd. Measures resistance, range 50 ohms to 2 megohms. Measures power factor, range 0 to 50%; measures insulation resistance, detects defective capacitors. Has continuity meter, color-coded scales; is compact, portable. Unit weight 8 lbs.
- **STANDARD MODEL CB-1-60** Capacitor Analyzer. Dealer Net Price \$26.00. A very popular instrument. Meets the requirements of radio service engineers and technicians for an inexpensive analyzer which will accurately determine the important electrical characteristics of all types of electrolytic, paper, mica and air condensers. Unit weight 7 lbs.

Contact our nearest branch, listed below, for rapid delivery.

*Available for prompt delivery to dealers and servicemen on an AA-5 priority which WPB issues on application.

**RADIO ELECTRIC
SERVICE CO.**

Main Store: N. W. Cor. 7th & Arch Sts., Philadelphia, Pa.

— BRANCHES —
PHILADELPHIA:
3145 N. Broad St., 5135 Market St.
ALLENTOWN, PA.:
1042 Hamilton St.
CAMDEN, N. J.:
513 Cooper St.
WILMINGTON, DEL.:
219 W. 8th St.

OHMITE RESISTORS

*for accurate
trouble-free*

SERVICE

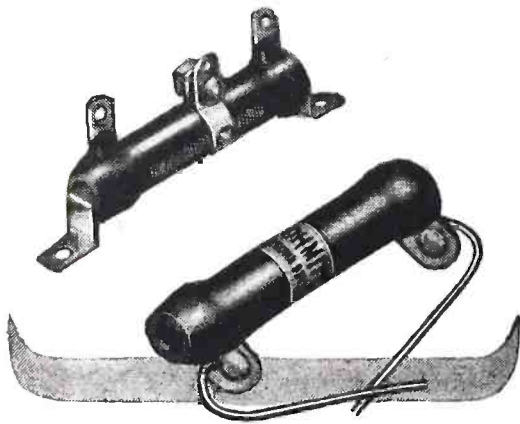

Time-proved, battle-proved, service-proved... Ohmite Brown Devils and Adjustable Divid-ohms are used today in critical war equipment. After Victory . . . these dependable units will again be the favorite of radio servicemen who want and use the best for resistor replacements.

For information about these and other Ohmite Resistors, write for Stock Unit Catalog 18.

SEND FOR HANDY OHM'S LAW CALCULATOR

Figures ohms, watts, volts, amperes—quickly, accurately. Solves any Ohm's Law problem with one setting of the slide. Send only 10c in coin for handling and mailing. (Also available in quantities.)

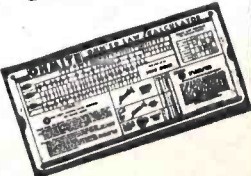

OHMITE MANUFACTURING CO.
4896 Flounoy Street • Chicago 44, U.S.A.

Be Right with **OHMITE**
RHEOSTATS • RESISTORS • TAP SWITCHES

ALIEN ENEMY PATENTS (Continued from page 158)

of a parabolic reflector. Note that all radiation within angle AFB does not strike the reflector destroying the beam effectiveness. Therefore, a reflector, circular in shape, is built in front. Now in order to handle the latter reflections another circular reflector is built at the rear replacing the corresponding parabolic section (dotted). Radii of the two circular sections are some odd number of quarter wave-length so that reflections due to them are reflected back to the antenna.

RELAXATION OSCILLATOR

Patent No. 2,157,529

GAS discharge oscillators provide great output while vacuum discharge oscillators enable reaching of very high frequencies. This invention combines the advantages of each (Fig. 9). It consists of an electron multiplier device with heated cathode. Normally the beam travels in a straight line striking electrode E, while electrodes A and B deflect it when a suitable EMF is impressed across them.

When condenser C becomes charged, its high voltage causes these plates to deflect the beam which strikes electrode 1, from which secondary electrons are emitted to strike electrode 2, etc. The stream of electrons, greatly multiplied in the last stage (between 3 and 4) causes condenser discharge and the cycle repeats. Magnetic fields at H and static fields at 5, 6, 7 deflect electrons from one electrode to the next.

WIDE BAND AMPLIFIER

Patent No. 2,164,899

IN the UHF bands used for television and FM one of the great difficulties is that of providing wide range amplifiers. In Fig. 10 a wide band of frequencies may be received by using damping resistors. An RF coil and an AF coil are in series in the plate circuit. However, the resonant point of each is broadened by the damping parallel resistors, so that a range of 16 cycles to 1 megacycle may be covered.

UHF DETECTION

Patent No. 2,165,726

FOR detection of very feeble UHF voltages it is necessary that even slight changes of capacitance, resistance or inductance in the circuit be avoided, which limits the methods which may be used. In Fig. 11 the RF is led directly to a very high resistance filament sealed in a vacuum tube. The slightly heated filament changes the gas pressure and in turn this changes the conductivity of the large filament at the other end of the tube. The resistance of the latter filament may be measured by bridge means. Note that no disturbing influences react on the RF source.

AUTOMATIC BAND-WIDTH REGULATION

Patent No. 2,245,731

WHEN weak stations are being tuned in it is desirable that the response curve be sharp and of as great amplitude as possible. In this way greater sensitivity and less response to noise is obtained. On the contrary it is better that the curve be broad and of lesser amplitude for reception of powerful signals so that high fidelity and less likelihood of overloading results. In Fig. 12 is illustrated an ingenious yet simple scheme for providing these adjustments automatically. Drum D operates on the same shaft as the tuning condenser C. The AVC potential passes through this drum which is made of a semi-conducting material such as agate or marble.

When a certain strength of signal is received the AVC voltage with respect to ground is such that an attractive force is exerted between drum and the belt passing over it, creating friction. Therefore the belt will move one way or the other (against spring action) when the tuning condenser approaches the vicinity of a powerful station. Coil K is pivoted at M and the shaft A is fastened to the belt so that any belt movement will decrease coupling between L¹ and K. Therefore as a strong station comes in the response curve becomes broad and low, returning automatically to a high, sharp curve as the station is passed. The L coils determine a band-pass circuit, two of which are shown.

LATTER-DAY COHERER

Patent No. 2,228,064

CONVENTIONAL apparatus cannot be used for reception in the centimeter and millimeter bands. Here a novel arrangement becomes effective

in these ranges. A vessel is filled with tiny metallic particles of high conductivity. They may be kept in suspension either by means of a feeble air current or may float in a suitable medium. The particles are preferably of flat shape and ordinarily assume haphazard directions. However, under the influence of UHF they become dipoles and assume positions as shown (Fig. 13). Their deflection towards the vertical depends upon strength of signal. A source of constant light passes through the tube on to a photocell. Therefore the light is modulated at a rate equal to the modulations of the UHF and the device is a UHF detector.

WIDE-RANGE AMPLIFIER

Patent No. 2,248,476

IN resistance-coupled amplifiers the limit of high frequency response is reached due to shunting capacitances of the load and succeeding tube. As analyzed in Fig. 14, these are Ca due to the tube anode, Cs due to the load, Ce the grid-cathode capacitance of the next tube and Cz the equivalent capacitance due to the plate-grid

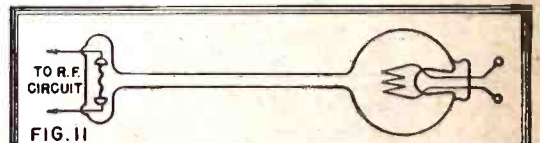

FIG. 11

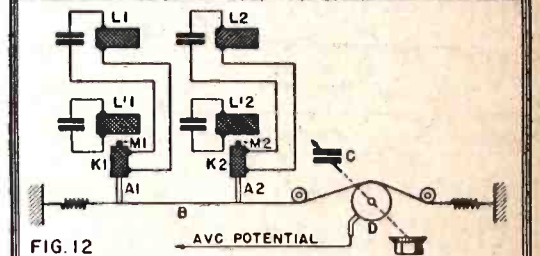

FIG. 12

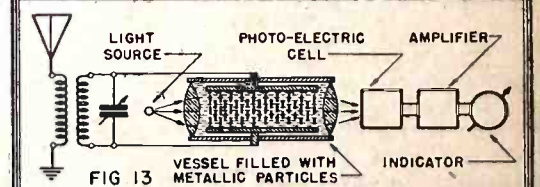

FIG. 13

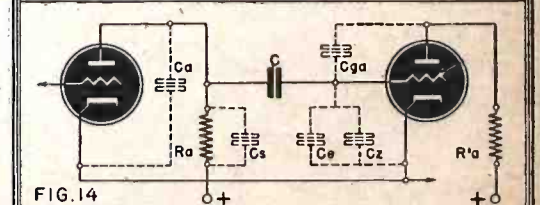

FIG. 14

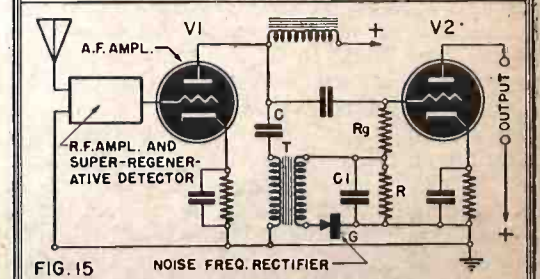

FIG. 15

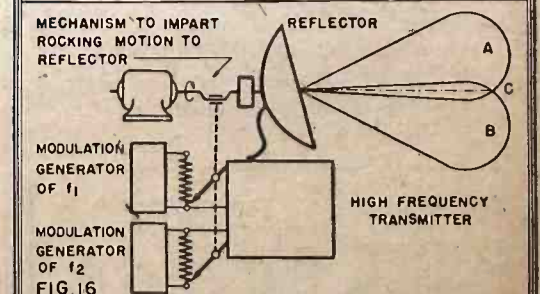

FIG. 16

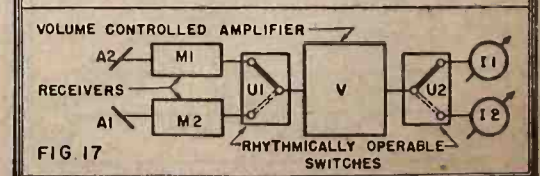

FIG. 17

capacitance and load of the following tube. As can be seen, the first three have a certain irreducible minimum. The last can, however, be varied and is, in fact, equal to $C_z = C_{ga} (A + 1)$ where A is the amplification of the second tube. By using a negative resistance circuit such as a dynatron or transitron the fourth capacitance can actually be made negative and used to reduce the total of the four. It must be remembered that a negative resistance circuit will serve to make the second tube output voltage in phase with the input.

SUPERREGENERATIVE RECEIVER
Patent No. 2,279,095

ONE of the bad features of a superregenerative receiver is its high noise level between stations. In Fig. 15 the noise frequencies between 10 and 15 KC are resonated by C and the transformer primary, are rectified and applied across R as a blocking potential shutting out all response when this noise level reaches a pre-determined peak, such as between stations.

RADIO BEAM
Patent No. 2,283,054

TRANSMISSION of a course beam may be greatly simplified by the use of a set-up as in Fig. 16. Use is made of a high frequency beam which may be reflected by the motor-driven arrangement.

Two modulation frequencies are synchronously transmitted such that when the beam is pointing, say at A, one of these tones is transmitted, while the other tone is transmitted when the beam is in its other extreme position, B. A synchronous potentiometer moves simultaneously with the reflector motor. An aircraft coming in from point A hears one tone, while one coming in from B would hear the other. From the neutral position C, it would pick up an equal amount of each modulation frequency. Direction of flight is thus easily determined.

RADIO BEAM RECEPTION
Patent No. 2,169,742

THE usual loop method of radio signal reception has the disadvantage of difficulty in indicating maximum and minimum. As is known, the former is not sharp and the latter, while theoretically obtainable often does not exist due to disturbing influences. Fig. 17 shows a synchronized switch U1 and U2 which alternately connects one loop to one indicator and the other loop to the other indicator, the loops being at right angles.

The volume controlled amplifier is of the usual AVC design except that the time constant is chosen to be equal to the time interval of the switching arrangement. Now assuming the loops operated so that one receives more energy than the other, the AVC will lag by the timing of the switch. Therefore when the weaker signal is received, the gain of the amplifier will be low and vice versa, giving a sharper indication of loop position with respect to incoming station.

Electronic induction methods can put 10 times as much heat into a piece of work as can the next hottest device, the oxygen torch.

\$3.00 FOR YOUR CARTOON IDEAS

RADIO-CRAFT, as you will have noticed, prints a number of radio cartoons, which we intend to keep on publishing every month indefinitely. We invite our readers to contribute to this feature by sending in their ideas of humorous radio ideas which can be used in cartoon form. It is not necessary that you draw a sketch, but you may do so if you so desire.

RADIO-CRAFT will pay \$3.00 for each original idea submitted and accepted.

We cannot return ideas to this department nor can we enter into correspondence in connection with them. Checks are payable on acceptance.

Address all entries to RADIO CARTOONS, c/o RADIO-CRAFT, 25 West Broadway, New York 7, N. Y.

HARRISON HAS IT!

FOR URGENT WAR WORK—

HALLICRAFTERS

RECEIVERS AND TRANSMITTERS

**TUBES
CONDENSERS
RESISTORS
TRANSFORMERS**

AND THOUSANDS OF OTHER CRITICAL ELECTRONIC PARTS!

PURCHASING AGENTS—

Call upon us for your high priority requirements of equipment and components for your production and development work.

We usually have it in stock!

FOR THE HOME FRONT—

CODE PRACTICE SET

Buzzer and key, heavily nickel plated, of single unit construction, mounted on wood base. Adjustable high frequency pitch. Complete with silk covered cord, in attractive box with code chart on cover. Works on one or two flashlight or dry cells.

Postpaid—\$2.45

6L6G First grade, \$1.37 ea.
meter tested, 3 for \$3.75
TUBES fully guaranteed postpaid

DYKANOL CAPACITORS

Cornell-Dubilier oil filled, hermetically sealed metal cased condensers. 4 mfd. capacity. Rated at 220 Volts AC working, will stand over 600 Volts D.C. Ideal for amplifiers, receivers, power packs, etc. (Filtering action equivalent to 12 mfd. electrolytic but with better safety factor, longer life). \$2.25 (3 or more shipped postpaid).

P. M. DYNAMIC SPEAKERS

5 inch, with output transformer to match single plate of 8000 ohms \$1.95

(Not Postpaid)

Immediate delivery of the above items, without priority, while quantities last. Place L-265 or V-3 certification on your order. SEND REMITTANCE WITH ORDER, TODAY! (Money back if not satisfied.)

HARRISON
RADIO CORPORATION

11 WEST BROADWAY

Phone WOrth 2-6276

NEW YORK CITY 7

Send for it NOW!

CONCORD RADIO CORPORATION'S

New 16-page supplement!

HARD-TO-GET RADIO PARTS

- Resistors
- Condensers
- Switches
- Speakers
- Wire
- Volume Controls
- Rheostats
- Test Accessories
- Transformers
- Relays



Here's a real bonanza of radio parts. All items listed have been designated by Concord customers as "urgently needed." All are from well-known manufacturers. All are priced right. Remember, they'll go fast—rush your request for this Special Supplement!

Only the name has been changed! Just another reminder that **LAFAYETTE RADIO CORPORATION** is now known as **CONCORD RADIO CORPORATION**

For 22 years, the Lafayette Radio Corporation has been one of the great arsenals for radio and electronic equipment. Although we are now known as the Concord Radio Corporation, we assure you that only the name has been changed. You will find the same personnel, the same high quality of merchandise, the same low prices, and the same reliable services as heretofore. Shop by mail or visit us personally... fully confident of guaranteed satisfaction. Be sure that your name is on our mailing list for postwar catalogs.

MAIL COUPON TODAY for the New, 16-page Supplement of "Hard-to-Get Radio Parts" by Concord Radio Corporation!
CONCORD RADIO CORPORATION
901 W. Jackson Blvd., Chicago 7, Ill.,
Dept.
Please rush me the new 16-page "Special Supplement" by Concord Radio Corporation.
NAME
ADDRESS
CITY STATE

CONCORD RADIO CORPORATION

Lafayette Radio Corporation

901 W. Jackson Blvd., CHICAGO 7, ILLINOIS ★ 265 Peachtree St., ATLANTA 3, GEORGIA



NEED A SUPPLY
OF MATCHES?

SYLVANIA SERVICEMAN SERVICE

by
FRANK FAX



Book matches, imprinted with your name, are one of the best and most economical ways to advertise your business.

Sylvania has prepared a new style of book match for your use.

Supplied to you for cost, with your name handsomely imprinted:

1,000 .. \$3.25 5,000 .. \$14.90
2,500 .. 7.50 7,500 .. 22.40

Plus 40 cents per thousand Federal Tax. Orders under 7,500 are shipped FOB Shipping Point; over 7,500, FOB your address.

Order from your local Sylvania distributor, or send your order to Frank Fax, Sylvania, Emporium, Pa.



SYLVANIA
ELECTRIC PRODUCTS INC.
RADIO DIVISION

BROADCAST EQUIPMENT *(Continued from page 147)*

choice of which is made by means of a screwdriver adjustment of selector switch S2. The 600-ohm pad is predicated upon the use of a standard equalized 600-ohm line. For short unequalized lines, the 150-ohm pad may provide better frequency characteristics, as the resulting impedance mismatch tends to compensate for the shunting effect of the distributed capacitance of the line.

The switching circuits (K1, K2) permit great flexibility and utility. When either key is in the downward position (contacts up), the line at its terminals is connected to the output of the amplifier through the resistance network. In the upward position, either key connects its associated line to the TEL jack and TEL binding posts. When two lines are available, one key remains down and connects to the program line, while the other key stays up and connects to the order wire. Then a standard telephone handset is plugged into the TEL jack or connected to the TEL binding posts, thus providing voice communication with the master control-room or transmitter at all times. However, when the order phone is used while the program is on the air, caution must be observed that the remote engineer's voice is not simultaneously picked up directly over the program microphone.

This switching arrangement allows a valuable safety factor, in that the program line and order wire are instantly interchangeable in case of failure or other trouble, merely by reversing the key positions and making a corresponding switch at the receiving end of the line. In many instances, for the sake of economy only one telephone line is used. Usually in this case the telephone set is not used, and intercommunication is carried on instead with one of the program microphones and the remote amplifier for transmission, and the monitor headphones for reception. This allows perfect transmission of directions or preceding program cue, but has the disadvantage that no communication is possible while the remote program is actually in progress.

One or two headsets may be plugged into the MONITOR jacks, permitting the control engineer, as well as some other interested party, such as announcer, producer, sponsor, etc., to hear the program just as it goes on the air. If a large audience is present, and loud-speaker monitoring is necessary, it can be obtained without deranging the regular program facilities by plugging a high-impedance bridging-type amplifier into one of the MONITOR jacks. Of course, the usual precautions must then be taken to eliminate acoustical feedback from loud-speaker to microphone.

All long untreated telephone lines will deliver into their load a distorted reproduction, in which the high frequencies have suffered more attenuation than the lows. This is due to the distributed capacitance existing between adjacent wires of the program line, which acts as a short circuit to the higher frequencies.

Since capacitive reactance decreases as the capacitance and frequency increase, the longer the line used, and the higher the note transmitted, the greater is the attenuation introduced by the line. Although it might be possible to attempt to restore the higher frequencies with the use of a high-pass terminating amplifier, present practice is to correct this defect with the insertion of additional loss at the low frequencies in exactly the same proportion as the high-frequency attenuation due to line losses. Thus the loss incurred at every frequency is the same, and the resultant reproduction, although attenuated, is identical to that impressed upon the line as regards frequency characteristics. This is illustrated in Fig. 2, at the bottom of this page.

An equalizer is an electrical network consisting of the proper combination of resistance, inductance, and capacitance, usually connected in shunt across the receiving end of the line, preceding other apparatus. While a low-impedance series-type equalizer is desirable for some special applications, ordinarily a flatter response can be obtained with the parallel type shown in Fig. 3.

Coil (L) has low D.C. resistance (about 3 ohms) and forms a parallel resonant circuit with condenser (C) at about 5,000 c.p.s. In series with them is variable resistance (R), which may be a decade resistance box. The parallel tuned circuit presents a very high impedance to frequencies of resonance, so that very little energy is lost due to shunting at around 5,000 cycles and up. However, as the frequency drops below resonance, the tuned circuit impedance becomes less and less, allowing more and more of the lower frequencies to pass through it and be shunted across the line, to an extent governed only by the setting of the variable resistance (R). By proper adjustment of this resistance, the equalizer can control, within its range, the frequency response of any line. If the line is exceedingly long and if the losses are greater than about 12 db. at 1,000 c.p.s., several equalizing networks connected in parallel may be required to retain high quality. Since the amount of equalization necessary varies with the length and type of line, each program line problem must be treated as an individual case.

The next installment will discuss the adjustment of equalizers and describe the procedure for making a frequency run.

(To be continued)

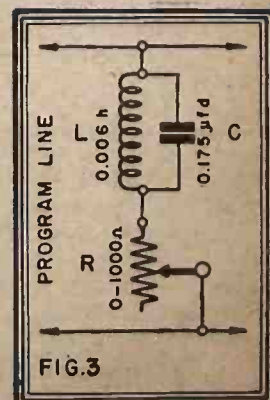
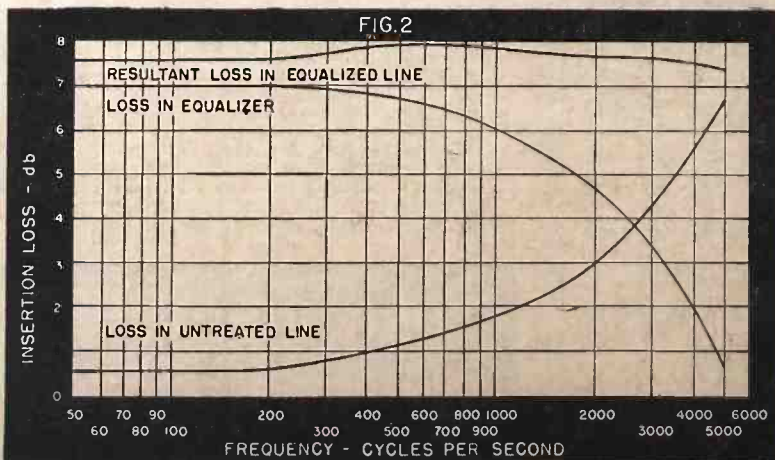

ICONOSCOPE

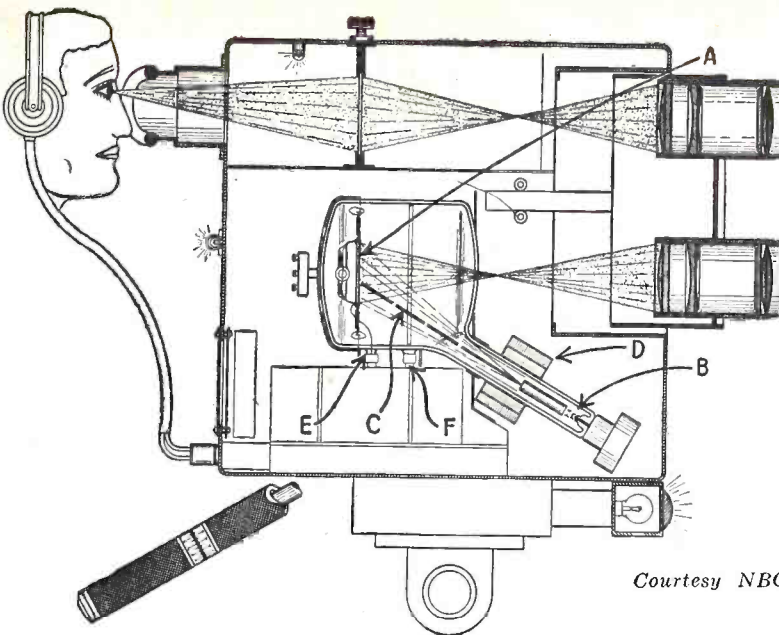

Courtesy NBC

H EART of the television camera is the Iconoscope. How the tube works may be seen in the cross-section drawing of a television camera.

The upper lens system is simply a "finder" for the operator, through which he keeps his subjects in view and in focus. The lower lens focusses light from the scene being televised onto the flat mica plate A, which is the Iconoscope's principal active element. The front of this mica sheet is covered with tiny globules of photo-electric material, making it a mosaic of independent photo-electric cells. The back of the sheet is plated with a thin film of metal, from which a lead is taken to the input of the television amplifier.

As light falls on each of these minute photocells, they give out electrons which go to a positive anode, whose only purpose is to remove them from the scene of action. As each globule loses electrons, it becomes positively charged. A corresponding negative charge is induced on the metal film on the other side of the thin piece of mica. Each light-sensitive element thus becomes a small condenser, varying in charge with the amount of light falling on it, and having for a common negative terminal the conductive film on the back of the mica sheet. We thus have an image of electric charges, as well as an image of light, on the mosaic.

A cathode-ray tube (which forms the

"handle" of the Iconoscope) is built into the tube. Electrons projected from the electron gun B are focussed into a beam C and caused to move across the face of the mosaic by the magnetic deflecting coils D, "scanning" it completely some thirty times per second. Each little photocell, when struck by the beam, takes from the electron stream a large enough number of electrons to bring it back to neutral voltage. In so doing, it releases an equal number of electrons which had been held on the conductive back film by condenser action. As the beam follows its regular course across the face of the mosaic, discharging each of the tiny condensers in turn, a series of minute pulses of current passes down the conductor E. These are applied to the grid-lead of the amplifier tube, creating a voltage across it in the standard manner. F is the terminal of the ring-shaped positive anode.

Since the amount of charge on each photocell element is proportional to the amount of light falling on it, the pulses vary in strength accordingly. Thus it is only

necessary to amplify them sufficiently, put them on a carrier to transmit them to the receiver, then in the receiver to turn the modulated electric current back into a beam of light and play it on a screen in exact synchronism with the original scanning beam of the Iconoscope to reproduce the scene being televised.

• **Ted McElroy**
 World's Largest Manufacturer of
 Wireless Telegraphic Apparatus
 COMPLETE CENTRAL OFFICE EQUIPMENT
McElroy Manufacturing Corp.
 82 Brookline Avenue • Boston, Massachusetts

PRACTICAL HOME-STUDY RADIO COURSE

These men used this course to get into good radio jobs



FINEST TRAINING COURSE USED IN MANY SCHOOLS

"The radio training course is the finest up to date easy to understand course. . . . This course outlines practical work. We are using this course in our Topeka High School. It is wonderful." *Henry Ward, Jr., 622 Filmore St., Topeka, Kans.*



WORTH MUCH MORE

"You should get more money for your Course. The first week I studied it, I made \$10.00 repairing sets. I built my own test outfit from details given in this course. I have repaired 100 radios to date. . . ." Signed: *Robert C. Hammel, 709 E. 10th, Davenport, Iowa.*



COMPLETED IN 8 WEEKS

"I am very satisfied with the course. When I was at the twelfth lesson I started repairing radios. It took me two months to master your course." From a letter written by *Roger Lanzlois, 1720 Poupart, Montreal, Canada.*



MODERN, UP-TO-DATE

"I have found since taking your course how modern and up to date it really is. There is not one page in the whole course which anyone interested in radio can afford to miss. Your course started me on the road to a well paid job and has repaid me many times." *Charles Alsopach, 433 Elm St., Reading, Pa.*

AMAZING BARGAIN OFFER

In this large course-manual of 22 practical lessons, you have all the topics covered by the best \$100.00 radio correspondence course. Learn important fundamentals. Speed-up radio servicing. Includes hundreds of circuits, thousands of repair hints, many servicing short-cuts.

RADIO TRAINING FOR HOME-STUDY

This practical home-study course will show you how to repair all types of sets faster and better, tell you how to open your own shop and run the business. The lessons are well illustrated, interesting to read, easy to understand and apply. No special previous knowledge is needed. The early lessons explain important principles. Other lessons cover test equipment, trouble-shooting, circuit tracing, television, and every other important topic of radio and electronics.

SERVICING METHODS SIMPLIFIED

Learn new speed-tricks for radio fault-finding, case histories, servicing short-cuts, extra profit ideas. Included are many large lessons on the use of regular test equipment, explanation of signal tracing, oscilloscope, transmitters, P.A., television, recorders. Let this information save for you enough time on a single job to pay the full price of \$2.50 for the complete course of 22 money-making lessons.

A PARTIAL LIST OF TOPICS COVERED

Circuits, Auto sets, P.A., Tube Characteristics, A.C., Fidelity, Using charts, Amplifiers, Tracking, I.F., Phase, Reactance, Impedance, Modulation, A.V.C., Photo-cell, Review questions, Crystals, Test equipment, Meters, Analyzers, Tube testers, Signal tracing, Oscilloscope, Ohm meters, Accuracy, Graphs, and hundreds of other topics.



IN MANUAL FORM

\$2.50
COMPLETE

SPECIAL OFFER
 READ THE DETAILS

EASY TO UNDERSTAND AND APPLY

The practical lessons making up this course-book are easy to follow and apply to actual radio jobs. Hundreds of radio facts that puzzled you will be quickly cleared up. You will find yourself doing radio repairs in minutes instead of hours—quickly finding the faults or making needed adjustments. Every new radio development of importance and thousands of time-saving radio facts are packed into this complete course-manual.

SATISFACTION GUARANTEED

Use coupon to order the Course for 10-day examination in your own home. Look over the material, read a few lessons, apply some of the ideas. Then decide to keep the lessons at the bargain price of \$2.50 (full price), or return the material and get a cash refund.

TRIAL ORDER COUPON

SUPREME PUBLICATIONS, 9 S. Kedzie Ave., Chicago 12, ILL.

Ship the complete Radio Course for 10 days use. I must be satisfied or you will refund my money.

- I am enclosing \$2.50, full price. Send postfree.
- Send C.O.D. I am enclosing \$..... deposit.

Name: RCD

Address:

(Use Coupon or Send Order in a Separate Letter)



**TECHNICAL
PERSONNEL
WANTED**

IS *Your* OPPORTUNITY HERE?

Think this over carefully. Where do you go from the spot you're in now? Are your surroundings friendly and full of promise for the future? Consider now the place you might fill in the electronic industry leadership assured to the fine staff of engineers, scientists, technicians at NATIONAL UNION RADIO CORPORATION. We're all young in years and ideas though most of us are old in electronic experience. We enjoy working together. We know we're going places! We're inviting you to join us if you have the qualifications. If you're looking for a success pattern for your future, it may be here with us at National Union. Find out! Come in and talk it over or write us!

NATIONAL UNION WANTS:

- * **QUALITY CONTROL ENGINEER AND SENIOR TUBE ENGINEERS**—These men **MUST** have executive ability and extensive experience with radio tube manufacture. The pay and opportunities are commensurate with your ability.
- * **COMMERCIAL ENGINEERS**—Men with pleasing personalities, initiative and a knowledge of vacuum tube applications.
- * **QUALITY CONTROL MEN**—Statistical Training is chief requirement though a knowledge of vacuum tubes will help.
- * **JUNIOR ENGINEERS—MEN or WOMEN**—If you have a college degree in Physics, Electrical Engineering, Mathematics or Chemistry and are the type of young person who is able to 'go places,' you'll be starting with your best foot forward if you are accepted at National Union Radio Corporation.
- * **FOREMEN and ASSISTANT FOREMEN**—Men with foremanship experience in exhaust, stem or grid operations in radio tube manufacture.
- * **TECHNICIANS, CIRCUIT MEN**—Maybe you've been repairing radios, maybe you've gained a knowledge of circuits by working on test equipment. It makes no difference either way if you have the 'know how' of circuits write us about the opportunities we have to offer!

WOMEN!

We have a number of fine young women engineers with us now. We need more. If you have a degree in Electrical Engineering, Physics, Chemistry or Mathematics and are seeking career opportunities, investigate.

Phone or Write

DR. L. GRANT HECTOR

Director of Engineering

NATIONAL UNION RADIO CORPORATION RESEARCH LABORATORIES

Plane St. at Raymond Blvd.

Newark 2, New Jersey

WMC RULES OBSERVED

ELECTRICAL and RADIO ENGINEERS RADIO TECHNICIANS

FOR DESIGN, DEVELOPMENT
AND PRODUCTION WORK
POST WAR OPPORTUNITY

ALLEN D. CARDWELL MFG. CORP.
81 Prospect St. Brooklyn

WANTED

RADIO LICENSED AMATEURS

thoroughly familiar with all types of parts, tubes, meters, test equipment, receivers, transmitters, etc., capable of dealing with our industrial accounts. Permanent position; excellent salary; splendid opportunity for some one residing in metropolitan New York area.

SUN RADIO & ELECTRONICS CO.
212 Fulton Street New York 7, N. Y.

Wanted ENGINEERS

Radio

Chemical

* Electrical

Electronic

* Mechanical

Metallurgical

* Factory Planning

Materials Handling

Manufacturing Planning

Work in connection with the manufacture of a wide variety of new and advanced types of communications equipment and special electronic products.

Apply (or write), giving full qualifications, to:

R.L.D., EMPLOYMENT DEPT.

Western Electric Co.

100 CENTRAL AV., KEARNY, N. J.

*Also: C.A.L.

Locust St., Haverhill, Mass.

Applicants must comply with WMC regulations

MODERN RADIO DICTIONARY

- AMPS—Little Devils.
- CATWHISKER—Mouse Detector.
- CHARACTERISTIC CURVES — Best seen at the sea-shore.
- CHOKE COIL—Primitive instrument of torture.
- FEEDBACK—Result of seasickness.
- MAGNET—Tiny worm.
- MICROPHONE—One millionth part of a headphone.
- MU—Cat's call.
- MULTIVIBRATOR—Hawaiian dancer.
- OHM—Where factory workers go at 5 p.m.
- PICK UP—A beautiful blonde.
- PUSH PULL—An accordion.
- RESISTANCE—What the boss puts up when you demand a raise.
- SOFT COPPER—A good-natured policeman.
- SWEEP CIRCUIT—Path traced by a vacuum cleaner.
- TERMINAL LUG—A bum in a railroad station.
- TOGGLE—What Roman Emperors wore.
- TOGGLE SWITCH—Persuader for small children.
- TRIMMER—Lawn mower.
- VARIABLE—Any woman.
- WAVE TRAP—A storm reducer used in ships.
- ZERO—A fiddler who wore a toggle.

—The New Zealand Radiogram

A new French station called *Information Permanente* broadcasts no entertainment programs. It confines itself to news broadcasts (15 per day) programs of the French radio, theater and cinema, stock-exchange prices and other types of factual information.

U. S. ROBOT BOMBS

(Continued from page 139)

Fortunately we have today a sure means of making the flying bomb an accurate military weapon and it can be done without adding greatly to its cost or complexity.

Since 1924 the writer has been advocating the television controlled robot bomber. He described it first in the November 1924 issue of the EXPERIMENTER magazine. This particular machine required six different television transmitters so that the ground operator who conducted the weapon by remote control, could see into six different directions all at once—namely East, West, North, South and up and down. Such a complex television transmitter is however not required in a flying bomb.

The writer here wishes to go on record and state his conviction that the Nazi flying bomb was incorrectly designed in that it was made to fly a course like an airplane at about 2000 feet altitude. That was the height of foolishness because fighter planes readily intercepted the flying bomb and near the coast of England they could often be shot down. A flying bomb should have a gun-projectile trajectory. It also should be shot at a high angle elevation so it will ascend into the stratosphere and then descend upon its target almost vertically. Using such a trajectory, no airplane can cope with the flying bomb and the means of attacking it becomes almost impossible. Even anti-aircraft guns will be found practically useless because the robot will be most difficult to track and radar will not be of too much help in the computation of the course of such a flying bomb.

If now we equip our robot bomb with a television scanner in its nose and if the television impulses are transmitted to the distant launching operators, the target can be accurately seen in good weather as soon as the falling bomb gets over it. Then by remote radio control the tail and the fins of the robot bomb can be adjusted so that it can be directed at almost any desired point. Note that it takes several minutes for the bomb to descend from its highest point as it emerges from the stratosphere before it hits. If a magnified view is projected on the receiving screen by the observer, it becomes relatively a simple matter to steer the robot bomb to its exact target, such as a factory, railroad station, bridge, war installations, or other military installations which we wish to destroy. It might be objected that, if given a sufficient amount of anti-aircraft guns, a strike is sure to be made on the falling bomb. Yet this is not a certainty and while lucky hits will be made at times the strength of the robot bomb lies in its numbers.

First, you do not have to sacrifice lives, as no human beings are in it. Second, the bombs can be launched from different directions all converging on one target. Consequently, if ten or twenty-five bombs are launched against an important military installation an appreciable number of them is certain to get through and neutralize or destroy the target.

We have all of the instrumentalities today, to make the television-conducted robot flying bomb a reality. It is the writer's fervent hope that it will be seen in operation soon, because it will certainly be of immense help in shortening the war.

U. S. Robot bomb parts are now being built for the ATSC (Army Air Forces Technical Service Command) by Ford Motor Co., Republic Aviation Corp., Monsanto Chemical Co., Alloy Products Co., General Electric Co., Sperry Gyroscope Co., Bell Aircraft Co., and Jack & Helms, Inc. A major part of assembling the completed robot bomb is being done by Republic Aviation Corp. Plant at Farmingdale, L. I., according to the U. S. Army.

ENGINEERS

Are You Concerned With ? YOUR POST WAR FUTURE ?

The Federal Telephone & Radio Corporation, the manufacturing unit of the International Telephone & Telegraph Corporation with its multiple business activities extending to all parts of the civilized world, will accept applications from experienced men for immediate employment with almost limitless post war possibilities. These positions should interest those with an eye to the future and whose interest lies in forging ahead with this internationally known organization whose expansion plans for post war are of great magnitude covering all types of radio & telephone communications. Advancement as rapid as ability warrants. Majority of positions are located in the New York area!

We need the following personnel! Men with long experience or recent graduates considered.

- ENGINEERS
- ELECTRONICS
- ELECTRICAL
- RADIO
- MECHANICAL
- CHEMICAL
- TRANSFORMER DESIGN
- SALES AND APPLICATION ENGINEERS
- PHYSICISTS
- DESIGNERS
- DRAFTSMEN
- TOOL DESIGNERS
- TECHNICAL WRITERS

Look Ahead With Federal!

If inconvenient to apply in person, write letter in full, detailing about yourself, education, experience, age, etc., to Personnel Manager.

FEDERAL TELEPHONE & RADIO CORP.

39 Central Avenue

EAST NEWARK

NEW JERSEY

ENGINEERS DESIGNERS

ELECTRICAL, MECHANICAL,
RADIO, ACOUSTICAL

For Research and Development Laboratory of large company fully engaged in war work manufacturing aircraft accessories. Activity includes electronic control equipment, continuous recorders, special radio devices, etc.

Excellent post-war opportunities. Laboratory located in central Manhattan. All replies strictly confidential. Write full details. Box 550 Equity, 113 W. 42nd St., N. Y. C.

SPECTROGRAPHY'S NEW AID

Phosphorescence, long considered little more than a pretty phenomenon, may become extremely valuable to research scientists, reports Dr. G. N. Lewis of the University of California.

Matter brought to the state of energy in which it phosphoresces gives off spectrum lines entirely different than those obtained with a spectroscope in the usual manner, said Dr. Lewis.

Many ordinary spectrographs resemble each other so closely that certain complex substances cannot be distinguished from each other by spectrographic means. In the phosphorescent state, Dr. Lewis found, each substance gives off a highly characteristic spectrum. Chemicals which differ from each other only in the minutest detail under usual analysis produce noticeably different spectra.

Spectrographic analysis may thus answer a number of previously unsolvable questions.

Transmitting or Receiving

RADIO STATION TECHNICIANS

MEN AND WOMEN

for Point-to-Point International
Radio-communications Stations
in the United States.

Applicants possessing at least
Second Class Commercial
Radiotelegraph Operator's License are preferred.

Essential workers need release
statement.

Apply weekdays except Saturdays
between 10 am and 3 pm

or write

PERSONNEL DEPARTMENT

R.C.A. COMMUNICATIONS, Inc.

64 BROAD STREET
NEW YORK 4, N. Y.

Some one once said that a good way to test the quality of whiskey is to pass an electric current through a quart of the stuff. If the current causes a precipitation of lye, tin, arsenic, iron slag and alum, the whiskey is fair. If, however, the liquor chases the current back to the generator, you've got good whiskey.

LARGEST STOCKS CENTRALIZED SERVICE

FREE Complete Up-to-date BUYING GUIDE

Everything in RADIO and ELECTRONICS

REPAIR and REPLACEMENT PARTS AVAILABLE without priority

SAVE TIME CALL ALLIED FIRST!

Thousands use Allied's nation-wide service. Centralized here are today's largest and most complete stocks under one roof. Over 10,000 items from all leading manufacturers . . . for the Armed Forces, Radio Training, Laboratories, Industry and Service Replacements. Our experienced staff simplifies procurement—expedites delivery. Call ALLIED first . . . for everything!

Write, Wire, or Phone Haymarket 6800

6 Radio Books for 75c

ALLIED'S RADIO DATA HANDBOOK	Dictionary of Radio Terms. No. 37-751 10c	Radio Data Handbook. No. 37-754 25c
ALLIED'S RADIO BUILDERS HANDBOOK	Radio Circuit Handbook. No. 37-753 10c	Radio Builders Handbook. No. 37-750 10c
ALLIED'S RADIO FORMULAS HANDBOOK	Radio Formulas & Data Book. No. 37-752 10c	Simplified Radio Servicing. No. 37-755 10c
ALLIED'S RADIO ELECTRIC HANDBOOK	All Six Books No. 37-799 . . . 75c	

Write for Quantity Prices

ALLIED RADIO CORP., Dept. 2-M-4
833 W. Jackson Blvd., Chicago, Ill.

Please send following books (.....c enclosed)

FREE 37-750 37-752 37-754
 Buying 37-751 37-753 37-755
 Guide No. 37-799 (All Six Books)

Name.....
 Address.....
 City..... State.....

ALLIED RADIO

MATCHING LOUDSPEAKERS (Continued from page 150)

necessary to err in either direction, connection should be made to taps of slightly lower than correct impedance. Thus the reflected impedance will be a little high. This will merely reduce the power slightly, whereas too low an impedance facing the output tubes would harm fidelity.

Speakers may also be matched by their output transformer primaries. Thus two 12,000-ohm primaries could be connected in parallel across the 6,000-ohm impedance of the output tube(s). This method is useful where speakers are some distance from the amplifier.

A quicker method of calculating the correct taps can be worked out from the example just given. Each speaker in Fig. 3 was so mismatched to its transformer winding that it got its own share of the power, yet all speakers when paralleled reflected the correct impedance back into the primary.

The method of distributing power is simple enough. Many servicemen do it unconsciously. With two 8-ohm speakers to attach to an output transformer, few would have to be told they could both be connected in parallel across a 4-volt tap. Each speaker is faced with an impedance half its own, and receives half the power. What could be more simple, if we wish to divide the power in parts of one-third and two-thirds, to tap one speaker across a tap 1/3, and the other across 2/3 its impedance? All we have to do is multiply the voice-coil impedance by the fraction of the output we want it to take.

But will matching to the output tubes be correct? Back to the 8-ohm speaker and 4-ohm tap again! A 4-ohm speaker would reflect the correct impedance back into the primary, and maximum power would be drawn from the amplifier. The 8-ohm speaker reflects 8/4 or twice the correct impedance back into the primary. If two of them are paralleled, each reflects its 12,000 ohms. The resultant of these two 12,000-ohm impedances in parallel is 6,000, the correct load. If our two 8-ohm

speakers are connected to divide the load into 2/3 and 1/3, the reflected impedances will be $8 \times 3/2 \times 6,000 = 9,000$ and $8 \times 3/1 \times 6,000 = 18,000$. Adding these impedances in parallel, the resultant impedance is 6,000, which is what we want.

The method can be extended to several speakers, as in the example of Fig. 4. Here we wish to supply 2 watts to a 500-ohm line, 6 watts to a 16-ohm and 12 watts to an 8-ohm speaker. This works out to 0.1, 0.3 and 0.6 of the total output (20 watts). Again assuming a primary of 6,000 ohms, we can get correct matching and power distribution by calculating output taps as follows:

For the 2-watt 500-ohm line, $500 \times 0.1 = 50$ ohms; for the 6-watt, 16-ohm speaker, $16 \times 0.3 = 4.8$ ohms; and for the 12-watt, 8-ohm tap, $8 \times 0.6 = 4.8$ ohms also. Reflected impedances are $6,000 \times 10 = 60,000$; $6,000 \times 10/3 = 20,000$ and $6,000 \times 10/6 = 10,000$. These paralleled impedances add up to 6,000 ohms.

By the above method it is possible to hook up the most complicated speaker combination. All that is necessary is to know the impedance of each speaker and the portion of the total amplifier power we want to put into each one. Another essential is an output transformer with a variety of taps. In conclusion, it might be well to point out that an output transformer has a large number of impedances not marked. For example, the impedance between the 2-ohm and 16-ohm tap is 6.6 ohms. Sometimes these odd ohmages make a closer match possible than would otherwise be the case.

References:

Matching Loud-speakers to Tapped Transformers, A. Coblenz, *Radio-Craft*, July, 1938. Page 26.
 A. F. Amplifier Load-Matching Technique, A. C. Shaney, *Radio-Craft*, March, 1940. Page 588.
 Speaker Matching Technique, H. S. Manney, *Radio-Craft*, June, 1940. Page 732.
 Output Transformers, Fred Shunaman, *Radio-Craft*, September, 1943. Page 726.
 Matching Speakers of Unequal Impedance, Richard W. Crane, *Electronics*, February, 1944. Page 256.

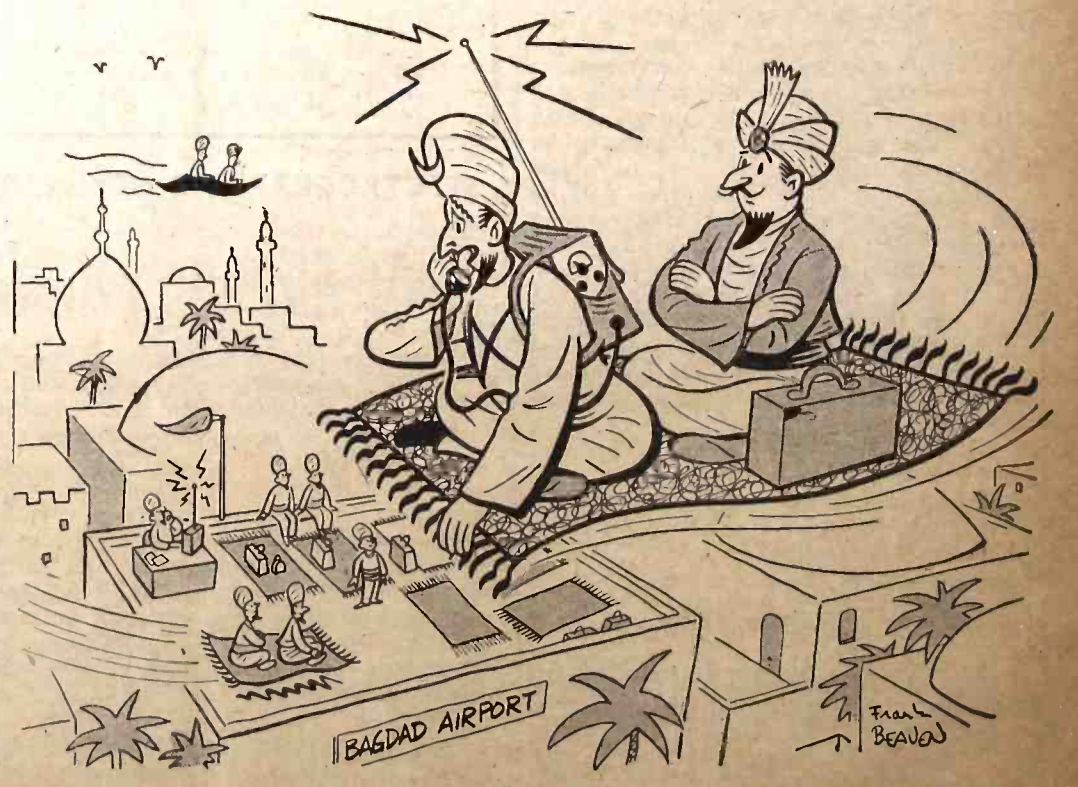

"How soon do you think I can land?"

FOR SALE HARD-TO-GET ITEMS

All items are brand new, except where indicated. ALL are in PERFECT WORKING ORDER. In many cases, the parts alone total more than the price we are asking. Satisfaction guaranteed or your money back. ORDER FROM THIS PAGE. Use our convenient coupon. Include sufficient extra remittance for parcel post charges, otherwise order is sent express collect. Any excess will be refunded. All C.O.D. shipments require 20% deposit. No C.O.D. shipments on orders for less than \$5.00. If full remittance accompanies order deduct 2% discount. Send money order, certified check, or new U. S. stamps. No C. O. D.'s to foreign countries.

THE MAGIC ELECTRIC WELDER



Here is one of the most compact, practical welders we have ever seen. Anyone can use it for shop, farm and home repairs. WELDS, BRAZES, SOLDER, CUTS ALL METALS. ANYONE CAN OPERATE IT. Repairs steel, cast iron, aluminum, brass, copper, bronze, etc. Complete with power unit, flame and metallic arc attachments.

(Really two welders in one). Carbons, fluxes, rods, mask included. Just plug it in any electric outlet. 110 volts AC or DC. For hobbyist or professional. GET IN ON THE GREAT WELDING BOOM. This fine set quickly teaches you welding. Low cost to operate—about 5c an hour. COMPLETE SAFETY is assured. No fumes with this outfit. SET COMES COMPLETE—nothing else to buy. Used by the U. S. Navy, American Tel. & Teleg. Co., Eastman Kodak Co., Bell Laboratories, etc. BRAND NEW OUTFIT. Guaranteed for one year. Simple instructions with each set. ITEM NO. 158 YOUR PRICE \$19.95

WESTERN ELECTRIC BREAST MIKE

This is a fine light-weight aircraft carbon microphone. It weighs only 1 lb.

Mike comes with breastplate mounting and has 2-way swiveling adjustment so that it can be adjusted to any desired position. There are 2 woven straps, one goes around neck, the other around chest. Straps can be snapped on and off quickly by an ingenious arrangement.



This excellent mike can be adapted for home broadcasting or private communication systems. By dismantling breastplate, it can be used as a desk mike.

Comes complete with 6-foot cord and hard rubber plug. Finished in sherdarized plate, non-rustable. THIS IS A BRAND NEW MIKE. IT HAS NEVER BEEN SOLD AT SUCH A LOW PRICE BEFORE. ORIGINAL LIST PRICE \$15.00. Shipping weight, 2 lbs. ITEM NO. 152 YOUR PRICE \$2.55

POWERFUL ALL-PURPOSE INDUCTION MOTOR

IDEAL FOR EXPERIMENTERS—101 USES



Sturdily constructed to precision standards, this self-starting shaded pole A.C. induction motor is powerful enough for a number of uses. Some of these are: Automatic Timing Devices, Current Interrupters, Electric Fans, Electric Chimes, Window Displays, Photocell Control Devices, Electric Vibrators, Small Grinders, Buffers and Polishers, Miniature Pumps, Mechanical Models, Sirens, and other applications.

Consumes about 15 watts of power and has a speed of 3,000 r.p.m. When geared down, this sturdy unit will constantly operate as an 18-inch turntable loaded with 200 lbs. dead weight—THAT'S POWER! Dimensions 3" high by 2" wide by 1 1/2" deep; has 4 convenient mounting studs; shaft is 1/8" long by 3/16" diameter, and runs in self-aligning oil-retaining bearings. Rated for 110-20 volts, 50-60 cycles, A.C. only. Shp. Wt. 1 lb. ITEM NO. 147 YOUR PRICE \$2.25

LIMITED QUANTITIES! PROMPT SHIPMENTS!

It's Easy to order—Clip Coupon—Order from This Page—No Catalog Sent. MAIL TODAY—NOW!

HUDSON SPECIALTIES CO.

40 West Broadway, Dept. RC-12-44, New York 7, N.Y.

I have circled below the number of the items I'm ordering. My full remittance of \$..... (include shipping charges) is enclosed. (NO C.O.D. ORDERS UNLESS ACCOMPANIED WITH A DEPOSIT.)

OR my deposit of \$..... is enclosed (20% required), ship order C.O.D. for balance. NO C.O.D. ORDER FOR LESS THAN \$5.00. (Now U. S. stamps, check or money order accepted.)

Circle Item No. wanted 147 152 158

Name

Address Please Print Clearly

City State

Send remittance by check, stamps or money order; register letter if you send cash or stamps.

SQUARE WAVE GENERATOR

(Continued from page 151)

at the top and round at the bottom, since the limiting resistor will have little or no effect on that part of the cycle when the grid resistance is infinite, or during that period of time no grid current is flowing.

Basically, square wave generators are used in trigger circuits. The output of the square wave generator may be fed into a differentiating circuit (the R-C combination of Fig. 7) having a short time constant, and the output will be a pulse.

A simplified illustration of a pulsing circuit is shown in Fig. 8. The positive half of the cycle is applied first. The condenser charges almost instantly, or during the time the amplitude of the square wave is reached. At this point, the condenser ceases to be further charged, and will discharge rapidly back through the resistor to ground. Since we now have no change in the applied voltage, there will be no further change until the negative half of the cycle.

On the negative half of the cycle, the condenser charges up almost instantly, but in the opposite direction, until the full negative amplitude of the wave is reached (Fig. 9). We again have direct current and the condenser discharges through R.

We now have two pulses, a positive and a negative pulse, one appearing on each half of the cycle.

POSITIVE OR NEGATIVE PULSES

To use these in trigger circuits, we may wish either a positive or a negative pulse, with the other clipped off. To get this, we can feed the pulsing circuit output into the grid of an amplifier, biased so that one or the other of the pulses may be removed.

Fig. 10 shows a positive pulse amplifier. With this amplifier, the tube is so biased that the positive pulse is clipped off through the action of the tube, and a positive pulse is left in the output.

Any positive voltage applied to the grid will cause the tube to instantly reach saturation. During this time there will be no plate current and the positive pulse is clipped off.

During the negative half of the cycle, the negative pulse is almost perfectly passed by the amplifier. The resultant wave form will be a positive pulse.

The negative pulse amplifier is so biased that any negative voltage that may be applied to the grid will cause the tube to be instantly cut off. On the positive half of the cycle, the pulse is passed by the amplifier. The output wave form will be a negative pulse.

The wave forms of the positive pulse generator may be shown graphically as in Fig. 11. This graph shows the wave forms with their true relationships as to phase and time, but without showing true relationship as to amplification. The lines are brought downward from the square wave input to the differentiating circuit, and the output wave form is developed. The wave form as taken from the output of the positive pulse amplifier is developed in the same manner.

Pulse generators may be used to trigger various electronic devices. Their value is well proven commercially as well as experimentally, as may be seen by the study of television circuits. Pulses are also used in many electronic industrial control circuits. The importance of the pulse and square wave generator is continuing to increase, and their study will well repay the radioman.



STOP!
don't
throw it away!

Let **RTS** reprocess
your dead

RADIO TUBES

NEW Scientific Process

REACTIVATES THORIUM
CONNECTS OPEN FILAMENTS
CLEARS SHORTS and
MICROPHONICS

(NOT the old "flash" trick)

MINIMUM ORDER 6 TUBES

SEND NO CASH 50¢ EA.
C. O. D. ONLY 1 volt & 3-Q5 \$1.00

30-Day Guarantee

Every tube fully tested in checkers & sets before playing

APPROVED BY OPA

Send itemized list with order

Make sure glass, base & prongs are intact... flashed, exploded or open cathodes **REJECTED** and **NOT RETURNED**

RTS RADIO TUBE SERVICE CO. INC.

6805 20th Avenue, Brooklyn 4, N.Y.

Servicing up to



of
**WARTIME
RADIOS**

● In keeping with the wartime spirit of minimum types for maximum jobs, Aerovox offers these two "first-aid" servicing items: Type PRS-V Dandees or tubular electrolytics, and Type '84 paper tubulars. They are now available in the standard "Victory Line" ratings taking care of 90% or better of all standard radio set requirements.

AEROVOX VICTORY CAPACITORS

Aerovox Type '84 paper tubulars. Individually tested. Extra-wax-sealed.

D.C.W.V.	CAPACITY
600	.001 mfd.
600	.002 mfd.
600	.005 mfd.
600	.01 mfd.
600	.02 mfd.
600	.05 mfd.
600	.1 mfd.
600	.25 mfd.

Aerovox Dandees Type PRS-V electrolytics. Individually tested. Extra-wax-sealed.

D.C.W.V.	CAPACITY
25	25 mfd.
50	10 mfd.
150	20 mfd.
150	20-20 mfd.
150	50 mfd.
250	20 mfd.
450	10 mfd.
450	10-10 mfd.
450	40 mfd.

● ASK YOUR JOBBER

Ask for these Aerovox Victory Capacitors to take care of your servicing. Ask for latest Aerovox catalog—or write us direct.



AEROVOX CORP., NEW BEDFORD, MASS., U. S. A.
In Canada: AEROVOX CANADA LTD., HAMILTON, ONT.
Export: 13 E. 40 St., NEW YORK 16, N. Y. Cable: 'ARLAB'

TECHNOTES

... SILVERTONE MODELS 7252, 7251

A number of these sets have come into the shop with the same complaint: loss of sensitivity on the entire broadcast band.

After considerable checking I found that the small fixed padder condenser in the oscillator circuit had changed capacity (probably due to temperature changes).

Replacement with an adjustable padder and realigning the low frequencies by the usual "rocking" method will work wonders with the gain and overall sensitivity of the set. The original padder has a value of .000425 mfd (425 mmfd).

C. J. LETT,
Hutchinson, Kans.

... PHILCO AUTO MODELS AR6

Intermittent operation and noise in these models can almost always be traced to the flexible shielding bond between the tuning condenser housing and ground.

I use a dial-drive spring soldered to the frame of the condenser and to a lug nearby for a ground. It is flexible enough so it will never break, and gives a very good ground. Realign condenser trimmers and I.F.'s for a permanent repair.

C. J. LETT,
Hutchinson, Kans.

... ZENITH MODEL 5724

To change from a 6F5 to 6K5 in these sets requires making only one connection. The sockets have removable tube-prong grips. There is a spare on the 6K7 socket. Remove it and insert through top on 6F5 socket in the vacant No. 4 hole. Then connect grips 3 and 4 together (underneath the socket). Now a 6K5 may be used instead of a 6F5 with the advantage of being able to shift back to 6F5 with no changes.

GEORGE BATCHELDER,
Wells River, Vt.

... CANADIAN SPARTON 5240

Secondaries of I. F. transformers open up. This is due to chemical action of dope on the form. The break is always on the inside of the coil next to the form.

Warm the coil form and the secondary can be slid off. The break is easily found. Remove one or two turns and replace, and the coil will be found to realign O.K.

The result is more permanent if dope is scraped off and one layer of cellulose tape put on.

R. LE ROY BLINN,
London, Canada.

... A.C.-D.-C. RECTIFIER FAILURES

If failures occur rather frequently in rectifiers and the cause cannot be traced to excess line voltage or bad components, it may often be due to excess peak currents. An easy remedy is to place resistors of approximately 25 ohms in each plate lead. This trouble occurs quite frequently in the higher heater voltage classes.

JOHN B. PARCHMAN,
Emporium, Penna.

... RECTIFIER SUBSTITUTIONS

Many of the later model AC-DC radios use a 50 volt tube as a rectifier in a voltage doubler or in the more common half-wave or full-wave circuits. Since the 50Y6 is hard to obtain at this time, suitable substitutes must be located. The type 50Z7G may be used in most cases without undue trouble. An examination of the 50Z7G shows that

(Continued on following page)

FOR SALE HARD-TO-GET ITEMS

All items are brand new, except where indicated. ALL are in PERFECT WORKING ORDER. In many cases, the parts alone total more than the price we are asking. Satisfaction guaranteed or your money back. ORDER FROM THIS PAGE. Use our convenient coupon. Include sufficient extra remittance for parcel post charges, otherwise order is sent express collect. Postage will be refunded. All C.O.D. shipments require 20% deposit. No C.O.D. shipments on orders for less than \$5.00. If full remittance accompanies order deduct 2% discount. Send money order, certified check, or new U. S. stamps. No C. O. D.'s to foreign countries.

ULTRA MAGNET

LIFTS MORE THAN 20 TIMES ITS OWN WEIGHT

LITTLE GIANT MAGNET

Lifts 5 lbs. easily. Weighs 4 oz. Made of ALNICO new high-magnetic steel. Complete with keeper. World's most powerful magnet ever made. The experimenter and hobbyist will find hundreds of excellent uses for this high quality permanent magnet. Measures 1 3/4" x 1 1/4" Ship. Wt. 3/4 lbs. ITEM NO. 159 YOUR PRICE \$1.50



GENUINE MICROPHONE TRANSMITTERS



These are regular "telephone transmitters" of the type used on wall telephones. Taken from a large telephone supply company's overstock, these fine mikes offer a grand opportunity to obtain a splendid unit for little more than the price usually asked for a simple "microphone button."

The amateur, experimenter and telephone mechanic will find a variety of uses for these excellent microphones. They work perfectly on 2 dry cells. Can be used on P.A. systems for voice transmissions, in call systems and intercom communications sets. With telephone receivers (radio headphones will do) they may be made into short-line telephone circuits, such as house-to-house or farm-to-farm "phone lines. You can use them to talk through your own radio, or as concealed dictaphone pick-up units for listening to conversations in a distant room or building. The telephone mechanic will find them useful replacements on battery-operated rural telephone lines. THESE ARE GENUINE TRANSMITTERS. MADE BY KELLOGG, WESTERN ELECTRIC AND STROMBERG-CARLSON, excellent in appearance and operation. A remarkable value, and one seldom offered in these times. Ship. Wt. 1 lb. ITEM NO. 140 YOUR PRICE \$1.50

AMAZING BLACK LIGHT!!

Powerful 250-Watt Ultra-Violet Source



The best and most practical source of ultra-violet light for general experimental and entertainment use. Makes all fluorescent substances brilliantly luminescent. No transformers of any kind needed. Fits any standard lamp socket. Made with special filter glass permitting only ultra-violet rays to come through. Brings out beautiful opalescent hues in various types of materials. Swell for amateur parties, plays, etc.; to obtain unique lighting effects. Bulb

only. Ship. Wt. 1 lb. ITEM NO. 87 YOUR PRICE \$2.45

WATTHOUR METER

Completely overhauled and ready for immediate service. Designed for regular 110-volt, 60 cycle 2-wire A.C. circuit. Servicemen use it in their shops to check current consumption of sets, soldering irons, etc. Keeps costs down. If dismantled, the parts alone would bring the price. The elaborate gear train could be used as a counter on machines of various kinds. Simple to install: 2 wires from the line and 2 wires to the load. Sturdily constructed in heavy metal case, 8 1/2" high, 6 1/2" wide, 5" deep. Westinghouse, G. E., Ft. Wayne, Sangamo or other available make. Ship. Wt. 14 lbs. ITEM NO. 33 YOUR PRICE \$5.95



TELEPHONE RECEIVER

This is a standard 75-ohm telephone receiver identical as used by public telephone companies. Slightly used but reconditioned. This telephone receiver has a powerful U-shaped magnet, genuine hard-rubber casing, two binding posts for connections. No cord is furnished, but receiver will take any standard cord. Receiver is quite sensitive and can be used for a variety of purposes, particularly in connection with our microphone transmitter shown above. Limited supply. Size: 5 1/2" overall x 2 3/4" diameter. Ship. Wt. 2 lbs. ITEM NO. 162 YOUR PRICE \$1.85



HUDSON SPECIALTIES CO.
40 West Broadway, Dept. RC-12-44, New York 7, N. Y.

I have circled below the numbers of the items I'm ordering. My full remittance of \$..... (include shipping charges) is enclosed (NO C.O.D. ORDERS UNLESS ACCOMPANIED WITH A DEPOSIT.) OR my deposit of \$..... is enclosed (20% required), ship order C.O.D. (for balance, NO C.O.D. ORDER FOR LESS THAN \$5.00. (New U. S. stamps, check or money order accepted.) Circle Item No. wanted: 33 87 159 160 162

Name

Address Please Print Clearly

City State

Send remittance by check, stamps or money order; register letter if you send cash or stamps.

OPPORTUNITY AD-LETS

Advertisements in this section cost 20 cents a word for each insertion. Name, address and initials must be included at the above rate. Cash should accompany all classified advertisements unless placed by an accredited advertising agency. No advertisement for less than ten words accepted. Ten percent discount six issues, twenty percent for twelve issues. Objectionable or misleading advertisements not accepted. Advertisements for January, 1945, issue must reach us not later than November 28, 1944.

Radio-Craft • 25 W. B'way • New York 7, N. Y.

PSYCHOLOGY THAT WORKS UNCOVERS PROFITABLE Opportunities; helps you find yourself . . . the real you; develops your Rich, Creative Talents. Dr. Tibolt 59C, 185 Godfrey, Phila 20.

PREPARE NOW FOR TREMENDOUS OPPORTUNITIES in new fields of radio after the war. Training for Federal licenses. Write for particulars, American Radio Institute, 44 East 23rd Street, New York 10, N. Y.

USED CORRESPONDENCE COURSES AND TECHNICAL Books Bought, Sold, Rented. Catalog Free. Educational Exchange, Henager, Alabama.

SAL-AMMONIAC TINNING BLOCKS 50 AND 75 cents. Dealers wanted. Opportune Products, Box 8, Normandy 21, N.Y.

BUILD A RADIO. COMPLETE KIT WITH TUBES. \$9.95. Details. Radio, 9418 Avenue "A," Brooklyn, N. Y.

300 WAYS TO MAKE MONEY

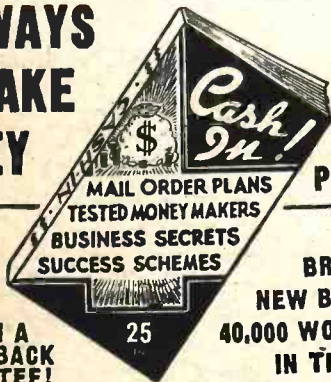

68 PAGES

25c Per Copy

SOLD ON A MONEY-BACK GUARANTEE!

In "CASH IN" you get ALL the real money-makers—dozens of profitable tested mail order plans, confidential business secrets, dozens of practical tested formulas, successful tested schemes—actual experiences of men who have started on a shoestring—with less than \$10 capital.

Buyers of This Book Tell Us—

"Biggest value I've yet to see. Book is worth at least a dollar." S. Buda, B'klyn, N. Y.

"Your book is as good if not better than others selling at \$1.00."

George Brunet, Montreal, Can.

"CASH IN" is the best value I have yet to see in the mail order field."

Lawrence Fox, Brooklyn, N. Y.

"CASH IN" contains only tested ideas covering every type of full- or spare-time enterprise—it's a "masterpiece" in business ventures.

25c a copy postpaid. Send U. S. stamps or coin.

NATIONAL PLANS INSTITUTE

P.O. Box 26R, Station N

New York 23, N. Y.

TRAIN FOR RADIO-ELECTRONICS IN 12 WEEKS I WILL FINANCE YOUR TRAINING

Prepare for a good job now with a peace time future in Radio-Electronics by 12 weeks of practical shop work in the great Coyne Shops. "Learn by Doing." Whether or not you have had Radio-Electronics experience you need Coyne training. Free Employment Service for life. Many earn while learning. Mail coupon today for free book which tells you how hundreds have become successful after taking our training.

We have facilities for men with physical disabilities. If you have a physical disability of any kind write me when you send the coupon.

H. C. Lewis, Pres., Radio-Electronics Div., Coyne Electrical School, 500 S. Paulina St., Dept. 94-7H, Chicago 12, Ill.
Send Free Radio Book and all the facts.

NAME _____

ADDRESS _____

CITY _____ ZONE _____ STATE _____

PATENTS—TRADE MARKS
Booklet concerning Inventions & Patents Form "Evidence of Conception" with instructions for use and "Schedule of Government and Attorneys Fees"—Free
LANCASTER, ALLWINE & ROMMEL
Registered Patent Attorneys
436 Bowen Bldg. Washington 5, D. C.

● BUY AN EXTRA WAR BOND ●

the actual heater is connected between pins 2 and 6 and is rated at 50 volts at 150 milliamps. A small coil of wire is connected between pins 6 and 7 to provide a 2.5 volt heater supply.

Although the tube could be substituted directly in many cases, care should be taken because many manufacturers use the unused socket lugs for connection terminals. If this is the case, a substitution which is temporary in nature or until a replacement is available may be made the lazy man's way by clipping No. 6 pin off of the tube base. This eliminates the necessity of changing socket connections. An efficient and permanent repair may be made by using an adapter or rewiring the socket as follows: Remove and isolate all leads from No. 6 socket lug. Move all connections from No. 7 lug to No. 6 lug.

Although the maximum current rating of the 50Z7G is slightly lower, it will work satisfactorily in most cases.

JOHN B. PARCHMAN,
Emporium, Penna.

... TUNABLE HUM

It has been my experience on several occasions to encounter tunable hum which was due to nothing more than a blown neutral fuse in the house circuit. In these cases the circuit was completed through an existing foreign ground caused by worn insulation on the neutral-leg of the house wiring, rubbing against the conduit.

An open neutral wire with a foreign ground return has also been found to cause the same trouble. In this case a new line wire has to be installed, where in the former a new fuse cured the trouble.

... ADAPTION TECHNIQUE

Type 7A4 will directly replace the XXL (triode) tube in all Philcos. It is also possible to make adapters or change sockets and use the 76 or 6J5 for such substitution. Make sure that in the case of the 7A4 no wires go to the "no connection" pins. After the war remember to replace again with the original XXL type which is, of course, superior for good FM reception.

If no local plugs are available, break off the glass top from the local tube, leaving intact the small glass bottom containing the pins. Clean the pins protruding on the tube side and solder on extensions to proper lugs. For more room between top socket and bottom plug base, cut off a cardboard mailing tube of proper size. Use a little service or bakelite cement and insert the local or octal base plug.

Amphenol molded sockets with spring mounting ring may be used without the ring for the top sockets. Mount on a bolt with a nut on either side through the hole in local or octal socket and turn down with a file in the chuck of a drill. The 4, 5, 6 and 7 hole sockets of the Amphenol type mentioned do not have a hole through the socket but instead a round depression on the under side which may be drilled through with reasonable care.

In connection with the above substitutions check the bias requirement from the tube manual since some cases may require a slight change.

It is wise to tell the customer that as soon as you can get tubes again, his set should be put back into original shape. Changes in wiring should then be put back exactly as in the original. We keep a file of changes made listed under the customer's name so that touchy circuits may be restored as originally factory made. After the war the data will thus be made immediately available.

WILLIAMS RADIO LABS,
Wapakoneta, Ohio

4 STANDARD TYPES
of Amperite Regulators replace over 400 types of AC-DC Ballast Tubes now in use.

Amperites are real REGULATORS . . . have patented Automatic Starting Resistor which prevents initial surge and saves pilot light . . . Ask Your Jobber.

AMPERITE

THE *Simplest* WAY TO REPLACE

BALLASTS

WRITE FOR REPLACEMENT CHART

AMPERITE Co. 561 BROADWAY, NEW YORK, N. Y.

Got Any **LAME DUCKS?**

Try Our **INSTRUMENT**

REPAIR SERVICE

Hard to get new testing instruments? Let our well-equipped Service Shop put your instrument in tip-top condition. For the duration—all makes—all repairs made by EXPERTS.

PRECAUTION—Before you ship, be sure to tell us make, model and serial number, also age of instrument, and what's wrong . . . thank you.

AUTHORIZED SUPREME SERVICE STATION

BURLINGAME ASSOCIATES

Service Division 23

11 Park Place New York 7, N. Y.

Send Only 10c For This Handy TUBE AND CIRCUIT REFERENCE BOOK

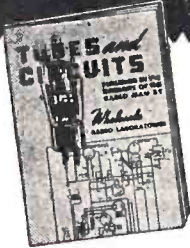

**OUR NEWEST
GET-ACQUAINTED
OFFER!**

Here's a handy reference book that meets the demand for simple, easy-to-understand data on substitution of radio tubes. Contains a special section devoted to valuable technical information on tubes and circuits. It's a guide you'll refer to time and again. You can't afford to be without it. Send for your copy today! Only 10c postpaid.

**TUBE-BASE
CALCULATOR
ONLY 25c**

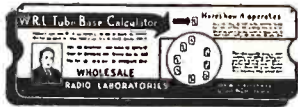

Here's just the calculator you've been looking for! Tells you quickly, tube characteristics that enable you to substitute available tubes for those hard to get. Send for one today. Only 25c. We pay the shipping expense.

FREE! Giant Radio Reference Map



Time zones, amateur zones, short wave stations and loads of other valuable information. Printed in colors; size 3 1/2 x 4 1/2 ft. It's yours free! Send 15c to help with packing and mailing.

WE'VE GOT THOSE HARD-TO-GET RADIO PARTS

You'll be surprised at the many hard-to-get parts we've been able to get for you fellows. Mikes, pickups, multi-testers, meters and many other items. They're yours as long as they're last. Send today for our latest flyer. It's full of merchandise you've been trying to get! Stocks won't last long, so send today!



HALLICRAFTERS

For many years we have been one of the country's largest distributors of Hallcrafters equipment. We have Hallcrafters available for immediate delivery on priority. For full particulars, write.

WHOLESALE RADIO LABORATORIES

744 W. BROADWAY
COUNCIL BLUFFS, IOWA

—Mail Coupon Today—

Wholesale Radio Laboratories RC-12
744 West Broadway
Council Bluffs, Iowa.

- Send your reference Book "Tubes and Circuits". Here's my 10c.
- You bet I want a Tube-Base Calculator. 25c is enclosed.
- Ship me your free radio map. 15c is enclosed for packing and mailing.
- Send your free flyer of hard-to-get radio parts.

Name.....

Address.....

Town..... State.....

I am an amateur; experimenter;
 service man.

MACHINE GUNS (Continued from page 144)

By placing these multiple, expendable television machine guns in exposed front locations, the high casualties of the past in the manning of machine guns will be practically done away with.

It will be pointed out that while this arrangement may be good during day-time, it is of no use during the night. Exactly the opposite is true. Baird, the English television authority, long ago invented his *Noctovisor* whereby subjects are televised in a pitch dark room, yet observers at the receiver see the features of the televised person clearly. This is done by means of infra-red rays. It is therefore a simple matter to place infra-red projectors somewhere in front of the machine gun. Indeed several such units can be used to guard the flanks of the machine gun position as well. The television transmitter, being sensitive to infra-red rays, the distant crew can see the approaching enemy in pitch darkness as well as in daytime.

While it is true that the infra-red rays do not reach over a great distance, yet they can be made to carry for several hundred yards without undue difficulty. Thus it will be impossible for the enemy to crawl up to the strong point at night and not be detected.

The new arrangement shows still another application of television which we may expect to see in use soon.

STATEMENT OF THE OWNERSHIP, MANAGEMENT, CIRCULATION, ETC., REQUIRED BY THE ACT OF CONGRESS OF AUGUST 24, 1912, AND MARCH 3, 1933.

Of Radio-Craft and Popular Electronics, published monthly at Springfield, Mass., for October 1, 1944.

County of New York } ss.
State of New York }

Before me, a Notary Public in and for the State and county aforesaid, personally appeared Hugo Gernsback, who, having been duly sworn according to law, deposes and says that he is the editor of Radio-Craft and Popular Electronics, and that the following is, to the best of his knowledge and belief, a true statement of the ownership, management (and if a daily paper, the circulation), etc., of the aforesaid publication for the date shown in the above caption, required by the Act of August 24, 1912, as amended by the Act of March 3, 1933, embodied in section 537, Postal Laws and Regulations, printed on the reverse of this form, to wit:

1. That the names and addresses of the publisher, editor, managing editor, and business managers are: Publisher, Radercraft Publications, Inc., 25 West Broadway, New York 7, N. Y.; Editor, H. Gernsback, 25 West Broadway, New York 7, N. Y.; Managing Editor, none; Business Managers, none.

2. That the owner is: (If owned by a corporation, its name and address must be stated and also immediately thereunder the names and addresses of stockholders owning or holding one per cent or more of total amount of stock. If not owned by a corporation, the names and addresses of the individual owners must be given. If owned by a firm, company, or other unincorporated concern, its name and address, as well as those of each individual member must be given.) Radercraft Publications, Inc., 25 West Broadway, New York 7, N. Y.; H. Gernsback, 25 West Broadway, New York 7, N. Y.

3. That the known bondholders, mortgagees, and other security holders owning or holding 1 per cent or more of total amount of bonds, mortgages, or other securities are: (If there are none, so state.) None.

4. That the two paragraphs next above, giving the names of the owners, stockholders, and security holders, if any, contain not only the list of stockholders and security holders as they appear upon the books of the company but also, in cases where the stockholder or security holder appears upon the books of the company as trustee or in any other fiduciary relation, the name of the person or corporation for whom such trustee is acting, is given; also that the said two paragraphs contain statements embracing affiant's full knowledge and belief as to the circumstances and conditions under which stockholders and security holders who do not appear upon the books of the company as trustees, hold stock and securities in a capacity other than that of a bona fide owner; and this affiant has no reason to believe that any other person, association, or corporation has any interest, direct or indirect, in the said stock, bonds, or other securities than as so stated by him.

5. That the average number of copies of each issue of this publication sold or distributed, through the mails or otherwise, to paid subscribers during the twelve months preceding the date shown above is.....
(This information is required from daily publications only.)

(Signature of publisher)

H. GERNSBACK.

Sworn to and subscribed before me this 11th day of September, 1944.

MAURICE COYNE, Notary Public
(Commission expires March 30, 1946)

[Seal]

TRAIN FOR
RADIO-ELECTRONICS IN 12 WEEKS
BY SHOP WORK
I'll Finance Your Training
Prepare for jobs in Radio-Electronics, by 12 weeks shop training in Coyne Shops. Free Employment Service. Many earn while learning. Whether or not you have had Radio Electronics experience you need Coyne training. Write for BIG FREE RADIO-ELECTRONICS BOOK, and my "pay-Tuition-After-Graduation" Plan.
H.C. Lewis, Pres., Radio-Electronics Div., Coyne Electrical School, 500 S. Paulina St., Dept. 94-78 Chicago 12, Illinois

Index to advertisers

Aerovox Corporation.....	186
Allied Radio Corps.....	184
Amperite Corporation.....	187
Audel & Company.....	165
Best Vibrator Co.....	168
Buck Manufacturing Company.....	189
Burgess Battery Co.....	174
Burlingame, Associates.....	176, 187
Burstein-Applebee Co.....	189
Cannon Co., C. F.....	168
Capitol Radio Engineering Institute.....	170
Cardwell Mfg. Co., Allan D.....	182
Concord Radio Corp.....	179
Coyne Electrical School.....	168, 187, 189, 190
DeForest's Training.....	135
Echophone Radio Co.....	161
Fada of New York.....	174
Federal Telephone & Telegraph.....	183
Galvin Mfg. Co.....	Inside front cover
General Cement Mfg. Co.....	189
General Electric Co.....	177
Hallicrafters Co., Inc.....	131, 132
Harrison Radio Corp.....	179
Henry Radio.....	175
Hudson Specialties.....	185, 186
Insuline Corporation of America.....	171
Kumfy Products Co.....	189
Lancaster, Allwine & Rommel.....	187
McElroy.....	181
McGraw-Hill Book Co.....	191
Maedel Publishing House.....	191
Meissner Mfg. Co.....	134
National Plans Institute.....	187
National Radio Institute.....	129
National Schools.....	137
National Union Radio Corp.....	136, 182
Nelson Company.....	168
Ohmite Mfg. Co.....	178
Onan & Sons, D. W.....	168
Opportunity Adlets.....	187

RADIO SCHOOL DIRECTORY

Page 192

Candler System
Capitol Radio Engineering Institute
Commercial Radio Institute
Lincoln Engineering School
Radio & Television Institute
RCA Institutes
Tri-State College

RCA Communications.....	183
Radercraft Publications, Inc.....	159, 167, 188
Radio Corporation of America.....	Back cover
Radio Electric Service Co.....	177
Radio & Technical Division.....	
Murray Hill Book Co.....	172, 173
Radio Tube Service Co., Inc.....	185
Raytheon Mfg. Co.—Inside back cover.....	
Sprague Products Co.....	163
Sprayberry Academy of Radio.....	133
Sun Radio Corp.....	182
Supreme Publications.....	181
Sylvania Electric Co.....	180
Trenton Radio Co.....	189
Universal Microphone Co.....	188
Western Electric Co.....	182
Weston Electrical Instrument Co.....	175
Wholesale Radio Laboratories.....	190

BOOK REVIEWS

MARINE RADIO MANUAL, edited by M. H. Strichartz. Published by the Cornell Maritime Press. Semi-flexible leatherette covers, 5 x 7½ inches, 518 pages. Price \$4.00.

First of its kind, this book aims to instruct the radio operator in what he needs to know, as he requires it. More than one fresh operator has had more trouble because he has appeared on the sailing date with no other papers than his radiotelegraph license than on account of any difficulties with the radio apparatus.

Chapter V of the Manual starts out with "Do's and Don't's for Beginners" and after impressing the new operator with some of the things he must not forget if he ever wants to become a radioman, goes on to Preliminaries, or instructions as to his seaman's papers. Then comes the important item, Getting a Job, and the more important one (up to the present neglected in all radio texts) Going Aboard. The operator is then told what is likely to be expected of him while in port on his first job. This information is often not obtainable elsewhere, as more than one operator can testify, yet the new "Sparks" is under observation and his reputation often depends on how he uses those first few days in port.

"Work at Sea" is the title of the next chapter, which covers such matters as when to go on the first watch, what matter the Master will expect him to copy and what not to copy, as well as the regular procedure of transmitting and receiving messages.

The remaining chapters of the book contain material that the operator has other access to, though only under a number of separate covers, and cover the "business" end of running a ship station, radio law, special communications, maintenance, trouble-shooting, direction-finders and similar items. Worthy of special attention is the section on word-counting, which contains several times the number of examples found in any other work.

INSTRUMENT FLYING AND RADIO NAVIGATION, by Holland L. Redfield. Published by the Ronald Press Co. Stiff cloth covers, 5½ x 8 inches, 195 pages, 107 illustrations. Price \$3.00.

Use of non-radio instruments is compressed into four chapters of 38 pages altogether. In this space the turn indicator, hall bank indicator, air-speed indicator, altimeter, vertical speed indicator, magnetic compass, clock, artificial horizon and gyro are described, with the gyro and artificial horizon receiving a short chapter.

The rest of the book deals with radio instruments and radio flying. Five chapters are devoted to radio ranging systems and navigating with the help of radio ranges. The radio direction finder then receives an equal amount of space. Methods of using the instrument to find a bearing and correct a course are described, as well as the use of the fixed direction finder.

The Link Trainer is dealt with in the final chapter.

Simply written and well illustrated, this book will be popular among flying students and persons interested in aerial navigation.

ELECTRONICS, TODAY AND TOMORROW, by John Mills. Published by D. Van Nostrand and Co. Stiff cloth covers, 5½ x 8 inches, 178 pages. Price \$2.25.

A popular book by a technical writer is often worth reading. Such is the case with this one, whose author, "sometime member of the technical staff, Bell Telephone Laboratories," has written on radio subjects from the time of the last World War and before.

Starting with a short historical outline: "New Sciences for Old," in which the continuity of electronics with earlier discoveries is stressed, he goes on to introduce electricity through its original form, lightning. "Man-Made Lightning" naturally follows, and the reader learns something of electrical quantities and the units in which they are measured.

Electronics proper begins with the fourth chapter, the first of six on the standard vacuum tube. These take the casual student from the hot cathode to tetrodes and pentodes, with a chapter on oscillators thrown in. The next two chapters are devoted to photo-electric and gas-filled tubes.

Electron optics and photography are dealt with in a chapter which gives considerable information on electron microscopes, and the Cyclotron receives a chapter, while two chapters are devoted to the ultra-high frequencies and U.H.F. operation, now brought so forcibly into the public eye because of military applications.

ULTRA-HIGH-FREQUENCY RADIO ENGINEERING, by W. L. Emery. Published by the MacMillan Co. Stiff cloth covers, 6 x 8½ inches, 295 pages. Price \$3.25.

Based on lecture notes used for two-and-a-half years in a course on high-frequency techniques at Iowa State College, this book had some of the advantages of revision before its publication. Written for senior electrical engineering students, a background of elementary communication and electronics is assumed. Mathematics including integral calculus is used. Numerical examples are used regularly.

The book is not entirely devoted to high-frequency communications theory, as the name might suggest. After the introduction, a chapter deals with voltage-regulated power supplies, and a second one with electronic switching and synchronization. Multivibrators, shaping circuits and discriminators are included in this chapter.

Amplifiers are treated with special attention to compensation for high- and low-frequency response, necessary in television and other circuits. Square-wave testing and transient response also receives a chapter.

Ultra-high-frequencies *per se* are handled under the chapter heads: Ultra-high-frequency Circuit Elements, Oscillators, Modulation and Detection, Radiation, and Wave Guides.

Each chapter is followed by a series of problems, and one or several experiments. There is also a list of references (books and magazine articles) at the end of each chapter.

NOW—A REALLY HIGH-POWERED— Radio Engineering Library

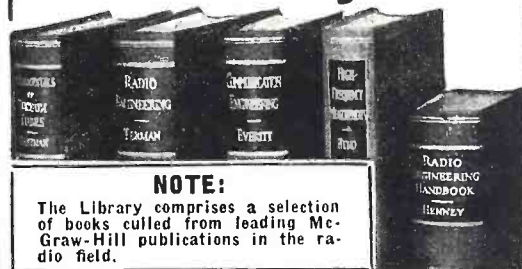

NOTE:

The Library comprises a selection of books culled from leading McGraw-Hill publications in the radio field.

- especially selected by radio specialists of McGraw-Hill publications
- to give most complete, dependable coverage of facts needed by all whose fields are grounded on radio fundamentals
- available at a special price and terms

THESE books cover circuit phenomena, tube theory, networks, measurements, and other subjects—give specialized treatments of all fields of practical design and application. They are books of recognized position in the literature—books you will refer to and be referred to often. If you are a practical designer, researcher or engineer in any field based on radio, you want these books for the help they give in hundreds of problems throughout the whole field of radio engineering.

5 VOLUMES, 3319 PAGES, 2289 ILLUSTRATIONS

1. Eastman's FUNDAMENTALS OF VACUUM TUBES
2. Terman's RADIO ENGINEERING
3. Everitt's COMMUNICATION ENGINEERING
4. Hund's HIGH FREQUENCY MEASUREMENTS
5. Henney's RADIO ENGINEERING HANDBOOK

10 days' examination. Easy terms. Special price under this offer less than books bought separately. Add these standard works to your library now; pay small monthly installments, while you use the books.

10 DAYS' FREE EXAMINATION—SEND COUPON

McGraw-Hill Book Co., 330 W. 42nd St. New York 18

Send me Radio Engineering Library, 5 vols., for 10 days' examination on approval. In 10 days I will send \$3.00, plus few cents postage, and \$3.00 monthly till \$24.00 is paid, or return books postpaid. (We pay postage on orders accompanied by remittance of first installment.)

Name
Address
City and State
Position
Company RC 12-44

MATHEMATICS FOR RADIO

Two volumes, prepared for home study. Book I (314 pp.) covers the algebra, arithmetic, and geometry; Book II (329 pp.) covers the advanced algebra, trigonometry, and complex numbers necessary to read technical books and articles on radio.

MAEDEL PUBLISHING HOUSE Room 117
593 East 38 Street, Brooklyn, New York

Send me MATHEMATICS FOR RADIO AND COMMUNICATION as checked below. I enclose payment therefor with the understanding that I may return the book(s) within 5 days in good condition and my money will be refunded.

Name
Address

- Book I at \$3.75 plus 6c postage
- Book II at \$4.00 plus 6c postage
- Books I and II at \$7.75 postage prepaid

Foreign and Canadian prices 25c per volume higher

RADIO SCHOOL DIRECTORY

PREPARE NOW FOR POST-WAR RADIO AND ELECTRONICS

MAKE a place for yourself in a new world of radio and electronics—a world in which revolutionary electronic developments will require highly specialized technical knowledge. Take a good course now to fit yourself for a good paying job. The training you need can be supplied by one of the schools advertised in this publication.

COMMERCIAL RADIO INSTITUTE

A radio training center for twenty-four years.

ACCREDITED FOR VETERAN TRAINING
RESIDENT COURSES ONLY

Pre-Induction, Broadcast, Service, Aeronautical, Television and Marine telegraphy classes now forming for February 5. Literature upon request. Home Study Course in Mathematics

Dept. C., 38 West Biddle St., Baltimore 1, Md.

RADIO ENGINEERING!

EX-SERVICE MEN can complete work here in shortest possible time. Special Prep. Dep't. Also REFRESHER COURSES. Courses also in Civil, Electrical, Mechanical, Chemical, Aeronautical Engineering; Business Administration, Accounting, Secretarial Science. Tuition, living costs low. 61st year. Cosmopolitan student body. Enter Jan., Mar., June, Sept. Catalog.

TRI-STATE COLLEGE 24124 College Ave. ANGOLA, INDIANA

RADIO TECHNOLOGY

RCA Institute offers an intensive two-year course of high standard embracing all phases of Radio and Television. Practical training with modern equipment. Also shorter specialized courses in Commercial Radio Operating, Radio and Television Servicing, and Aviation Communications. For Free Catalog write Dept. RC-44.

RCA INSTITUTES, Inc.

A Radio Corporation of America Service
75 VARICK STREET NEW YORK 13, N. Y.

Correspondence Courses in RADIO and ELECTRICAL ENGINEERING

ELECTRICAL ENGINEERING Get good grasp of wide electrical field. Prepare yourself, at Low Cost, for secure future. Modern, simplified, you can understand quickly.
RADIO ENGINEERING Extra fine course in radio, pub. lic address, photo-electric work.
Trains you to be super-service man, real vacuum tube technician. Servicemen needed badly. Diploma on completion. Tuition \$25, either course. Deferred payment plan.
FREE Get copies of school catalogs, student magazines, complete details. SEND NOW!
LINCOLN ENGINEERING SCHOOL Box 931-C70 Lincoln, Nebr.

WORLD-WIDE STATION LIST

(Continued from page 171)

to Thursday, 6:45 am to 10:15 pm; Friday and Saturday, 6:45 to 11 am.

6.135 — SUVA, FIJI ISLANDS; heard at 7 to 7:30 am.

6.140 WRUA BOSTON, MASS.; North African beam, midnight to 2 am.

6.140 DXX BERLIN, GERMANY.

6.150 GRW LONDON, ENGLAND.

6.150 CJRO WINNIPEG, CANADA; heard at midnight.

6.150 HJCD BOGOTA, COLOMBIA; 9 to 10 pm.

6.160 CBRX VANCOUVER, CANADA; 10:30 am to 2:30 am.

6.165 HER3 BERN, SWITZERLAND; 9:30 to 11 pm except Saturdays.

6.170 WCBX NEW YORK CITY; European beam, 11:45 pm to 3 am.

6.180 XGEA CHUNGKING, CHINA; heard morning; fem announcer.

6.190 — ATHLONE, IRELAND.

6.190 DXG BERLIN, GERMANY.

6.190 — TOKYO, JAPAN; heard early morning.

6.190 WGEX SCHENECTADY, NEW YORK; European beam, 9:15 pm to 2 am.

6.190 WGEO SCHENECTADY, NEW YORK; European beam, 12:15 to 3 am.

6.200 ZYC7 RIO DE JANEIRO, BRAZIL.

6.200 GRN LONDON, ENGLAND.

6.2 YV6RV BOLIVAR, VENEZUELA.

RADIO-TELEVISION ELECTRONICS

offer ever-increasing post-war opportunities for trained men and women. R-T 1 courses prepare you by combining theory with practical laboratory experience.

Consideration given to Veterans eligible for training under the G.I. Bill. Day & Evening Sessions. Apply daily 9-9, Sat. 9-2. Request Information.

Radio-Television Institute

480 Lexington Avenue, N. Y. 17 (46th St.)
PLaza 3-4585 Licensed by N. Y. State

CODE SENDING SPEED

Be a "key" man. Learn how to send and receive messages in code by telegraph and radio. Army Navy and Commerce need thousands of men. Good pay, adventure, interesting work. Learn at home quickly through famous Candler System. Write for FREE BOOK.

CANDLER SYSTEM CO.
Dept. 3-O, Box 928, Denver 1, Colo., U.S.A.

LOOK AT THE CAPITOL RADIO ENGINEERING INSTITUTE

MESSAGE ON PAGE 170

6.212 DKSA SENDER ATLANTIK; heard at 5:30 pm.

6.23 — MOSCOW, USSR; heard at 8:45 pm.

6.235 HRD2 LA CEIBA, HONDURAS.

6.243 HIIN CIUDAD TRUJILLO, DOMINICAN REPUBLIC.

6.27 HJCR BOGOTA, COLOMBIA; heard at 8 pm.

6.280 HIIZ CIUDAD TRUJILLO, DOMINICAN REPUBLIC.

6.330 COCW HAVANA, CUBA.

6.357 HRPI SAN PEDRO SULA, HONDURAS; heard about 10:30 pm Sundays.

6.380 HIIX CIUDAD TRUJILLO, DOMINICAN REPUBLIC.

6.385 HI9B SANTIAGO DE LOS CABALLEROS, DOMINICAN REPUBLIC.

6.405 TGOA QUEZALTENANGO, GUATEMALA.

6.440 HIIS SANTIAGO DE LOS CABALLEROS, DOMINICAN REPUBLIC.

6.47 COHI SANTA CLARA, CUBA.

6.480 TGWB GUATEMALA CITY, GUATEMALA; 7 am to 8:10 pm daily except Sunday.

6.63 HIT CIUDAD TRUJILLO, DOMINICAN REPUBLIC; heard at 8:45 pm.

6.990 XPSA CHUNGKING, CHINA; 1:20 to 3:10 am; 7 am to noon.

6.715 ZLT7 WELLINGTON, NEW ZEALAND; daily at 5:30 or 6 am.

6.90 XPSA KWEIYANG, CHINA; heard 10:30 pm to 12:16 am; also 4 to 9 am.

6.910 YNOW MANAGUA, NICARAGUA.

7.000 WGEO SCHENECTADY, NEW YORK; European beam, 11:45 pm to 3 am.

7.014 CMZI HAVANA, CUBA.

7.020 — PONTA DEL GADA, AZORES.

7.02 — MADRID, SPAIN.

7.053 COCL HAVANA, CUBA.

7.070 GRS LONDON, ENGLAND.

7.12 GRM LONDON, ENGLAND.

7.160 HCIBF QUITO, ECUADOR.

7.171 XGOY CHUNGKING, CHINA; East Asia and South Seas beam, 7:35 to 9:40 am; North America beam, 9:45 to 11:40 am; European beam, 11:45 am to 12:30 pm; East Asia and South Seas beam, 12:30 to 1:45 pm.

7.185 GRK LONDON, ENGLAND.

7.19 COCG HAVANA, CUBA; heard afternoons.

7.200 — STATION DEBUNK; heard evenings.

7.230 GSW LONDON, ENGLAND.

7.230 KWID SAN FRANCISCO, CALIF.; Oriental beam, 5:15 to 11 am.

7.24 DXJ BERLIN, GERMANY.

7.250 WGEO SCHENECTADY, NEW YORK; European beam, 12:15 to 3 am.

7.250 WBOS BOSTON, MASS.; East South America beam, 8:30 pm to midnight.

7.250 KGEI SAN FRANCISCO, CALIF.; Oriental beam, 6:45 am to 1 pm.

7.260 GSU LONDON, ENGLAND; North America beam, 8:15 pm to 12:45 am.

7.275 DXL25 BERLIN, GERMANY.

7.290 DJX BERLIN, GERMANY.

7.315 YSO SAN SALVADOR, EL SALVADOR.

7.32 GRJ LONDON, ENGLAND.

7.380 — BERN, SWITZERLAND; off at 11 pm.

7.395 — BERN, SWITZERLAND; North America beam, 4 to 4:30 pm.

7.435 FG8AH POINTE A PITRE, GUADELOUPE; heard about 8 to 10 pm.

7.520 KKH HONOLULU, HAWAII; news in English at 8 am.

7.565 KWY SAN FRANCISCO, CALIF.; Oriental beam and N.E.I. beam, 8:30 am to 12:30 pm; Sundays only, 9:30 am to 12:30 pm.

7.575 WLWO CINCINNATI, OHIO; European beam, 12:15 to 4 am.

7.575 WRUA BOSTON, MASS.; North Africa beam, 6:45 to 7:15 pm; 7:30 to 11:45 pm.

7.800 WOOW NEW YORK CITY; heard testing.

7.805 WRUL BOSTON, MASS.; North African beam, 2:15 to 5:45 am.

7.820 WOOW NEW YORK CITY; European beam, 7 to 9:15 pm; 9:30 pm to 3:30 am.

7.86 SUZ CAIRO, EGYPT.

8.000 — ATHENS, GREECE.

8.030 FXE BEIRUT, LEBANON (SYRIA).

8.035 CNR RABAT, MOROCCO; heard Sundays 5 to 6 pm.

8.220 — DAKAR, SENEGAL (FRENCH WEST AFRICA).

8.500 — TOKYO, JAPAN; early morning transmissions.

8.530 VUC6 CALCUTTA, INDIA.

8.600 COJK CAMAGUEY, CUBA.

8.70 COCO HAVANA, CUBA.

8.83 COCQ HAVANA, CUBA.

8.930 KES2 SAN FRANCISCO, CALIF.; N.E.I. beam, 6:45 am to 1 pm.

8.945 COKG SANTIAGO, CUBA; 7:30 am to 11 pm; at times later.

8.960 AFHQ ALLIED HEADQUARTERS, NORTH AFRICA.

8.960 APH ALLIED HEADQUARTERS, ITALY.

8.985 COKW HAVANA, CUBA; evenings.

Stations listed below are corrections and additions to parts two and three which were published in the past two issues. This list is printed in three parts to conserve space and thereby save paper, in support of the war effort. We ask our readers to bear with us this inconvenience until victory is ours and the present paper shortage is a thing of the past. We thank you.

9.120 — BALIKPAPAN, BORNEO; heard at 6 to 7 pm.

9.410 — LONDON, ENGLAND; to South America.

9.440 FZI "RADIO BRAZZAVILLE" FRENCH WEST AFRICA; heard about 4:40 pm.

9.490 — LONDON, ENGLAND; European service.

9.500 WOOC NEW YORK CITY; heard testing.

9.625 — LONDON, ENGLAND; South American service.

9.640 GVZ LONDON, ENGLAND.

9.660 — LONDON, ENGLAND; heard at 8:50 pm.

9.950 — NBC IN LONDON, ENGLAND; no sked known.

10.040 — BERLIN, GERMANY; heard evenings till about 9 pm.

10.290 — BERLIN, GERMANY; no sked known.

11.645 — BELGIAN NATIONAL RADIO; heard 8:30 to 8:40 pm; no sked.

11.780 — LONDON, ENGLAND; heard 7 to 10 pm.

11.785 — BELGIAN NATIONAL RADIO; heard at 9 to 9:15 pm; also 6:30 to 7 pm.

11.855 — "RADIO SHONAN," MALAYA; heard at 10:55 am.

12.190 LSN3 ARGENTINA; heard 7 to 7:15 pm; no sked known.

17.850 — BERLIN, GERMANY; evenings, heard at 10 am.

Commercials are not "laid on so thick" in Australian radio programs, according to R. E. Lane of the largest commercial "down-under" network. Sponsored newscasts are voluntarily prohibited by stations, and spot announcements have virtually disappeared from night programs.



NEW COMPLETE RADIO TUBE DATA BOOK BY RAYTHEON

THE new complete data on tubes, including characteristics, outlined drawings and basing diagrams of all standard receiving tube types; simplified interchange information including over 1600 substitutions; hearing aid tube data and technical information regarding radio panel lamps. All this is included in the new Raytheon Tube Data and Substitution Chart prepared by the Technical Service Department of Raytheon Manufacturing Company.

The value of the technical information in this manual is inestimable and yet it may be obtained FREE from your Raytheon receiving tube distributor. Every-

one concerned in the repair and maintenance of radios must have this ready reference book.

This manual is the first step in a tremendous merchandising plan which will bring you better business. This program teamed up with the superior, "Plus-Extra" quality Raytheon Tubes, will assure you of better customer goodwill, faster turnover and greater profits.

Raytheon Manufacturing Company

RADIO RECEIVING TUBE DIVISION

Newton, Massachusetts • Los Angeles • New York • Chicago • Atlanta



All Four Divisions Have Been Awarded Army-Navy "E" With Stars

RAYTHEON

High Fidelity

RADIO AND ELECTRONIC TUBES



DEVOTED TO RESEARCH AND MANUFACTURE OF TUBES FOR THE NEW ERA OF ELECTRONICS

Television broadcasts of boxing at Madison Square Garden, New York City, are brought to you exclusively by NBC over Station WNBT.

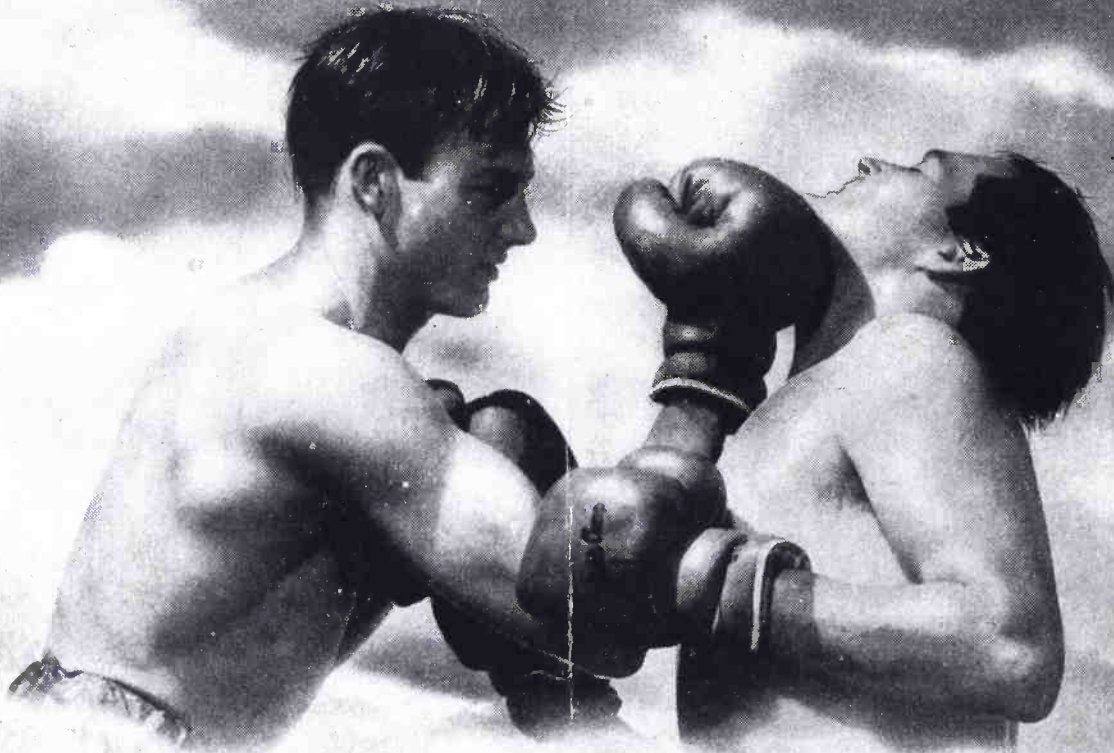

TELEVISION—THE “RINGSIDE SEAT”!

● Just as RCA pioneered in television to bring you exciting events such as prize fights, so has RCA research made possible a greatly improved super-sensitive television camera.

Earlier television needed a mid-day sun—or blinding artificial light—to illuminate the scene. Many performances could not be televised, and many outdoor daytime events would fade off the screen as the afternoon light waned.

But now, through RCA research, the television camera will faithfully reproduce every detail, every shadow, as long as there is enough light for the spectators themselves to see by.

Besides, it can bring you opera, drama, ballet—direct from the theater during the actual performance. Great new television thrills are in store for you! As soon as possible, RCA will make available the finest in television equipment.

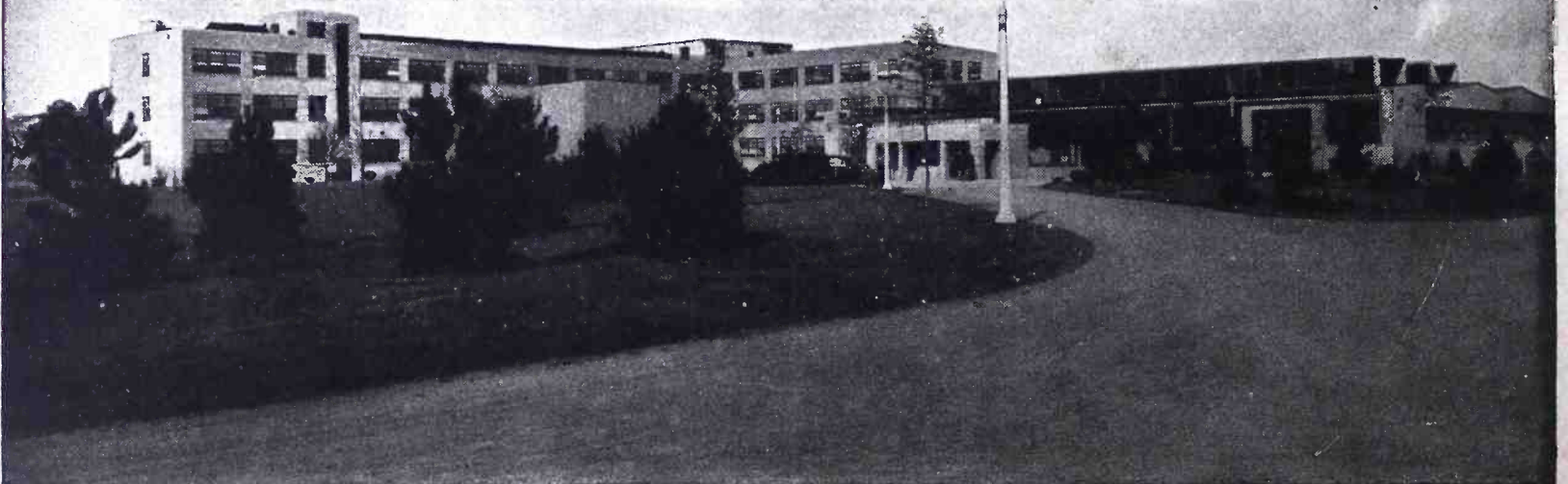

RADIO CORPORATION OF AMERICA

RCA LABORATORIES • PRINCETON • NEW JERSEY

RCA
leads the way in
radio—television—
phonographs—records
—tubes—electronics



Listen to RCA's "The Music America Loves Best"—Sunday, 4:30 P.M., E.W.T., over the NBC Network ★ BUY WAR BONDS EVERY PAY DAY ★

ADV Plans, LLC

Copyright Notice:

The entire contents of this CD/DVD are copyright 2014 by ADV Plans, LLC. All Rights Reserved.

Reproduction or distribution of this disk, either free or for a fee is strictly prohibited. We actively monitor and remove listings on eBay thru Vero.

You are free to copy or use individual images in your own projects, magazines, brochures or other school projects.

Only the sellers listed here are authorized distributors of this collection:
www.theclassicarchives.com/authorizedsuppliers

Please view our other products at
www.theclassicarchives.com,
or our ebay stores:

[TheClassicArchives](#)
[ADVPlans](#)
[SuperShedPlans](#)

